

# UNION & REDUCING UNION ELBOWS

# 50

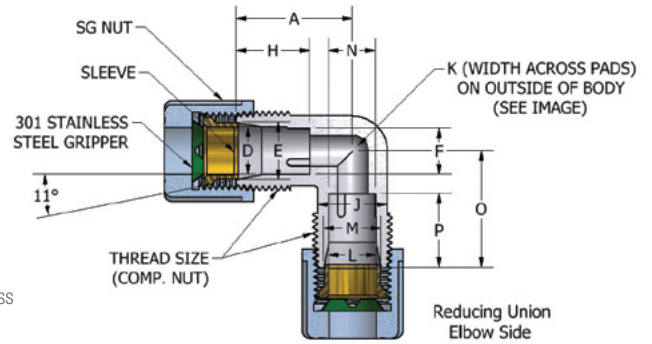

Diagram shown with Nut Style, SG, Stainless Steel Gripper Nut

## Union Elbows

JACO Part No.	Tube O.D.	Comp. Thd.	A	D	E	F	H	J	K
Conf. Tube Mtl. Nut			±1/64	+0.005 +.010		±1/64	+/-1/64	±1/64	±1/64
50 - 4 - P - O	1/4	7/16-20	13/16	.250	.330-.335	.170	15/32	3/8	3/8
50 - 5 - Z - SG	5/16	1/2-20	29/32	.312	.380-.385	.232	31/64	7/16	7/16
50 - 6 - C - O	3/8	5/8-20	15/16	.375	.460-.465	.250	19/32	9/16	9/16
50 - 8 - P - O	1/2	3/4-20	1-1/16	.500	.590-.595	.375	11/16	11/16	45/64
50 - 10 - P - O	5/8	7/8-20	1-1/4	.625	.715-.720	.500	45/64	13/16	55/64
50 - 12 - P - O	3/4	1-1/16	1-35/64	.750	.860-.865	.625	13/16	1	1
50 - 14 - P - O	7/8	1-3/16-16	1-9/16	.875	.995-1.000	.750	7/8	1-1/8	1-3/16

## Reducing Union Elbow

JACO Part No.	Tube O.D.	Comp. Thd.	A	D	E	F	H	J	K	L	M	N	O	P
Conf. Tube Tube Mtl. Nut			±1/64	+0.005 +.010		±1/64	±1/64	±1/64	±1/64	+0.005 +.010		±0.010	±1/64	±1/64
50 - 14 - 10 - -	7/8-5/8	1-13/16-20-7/8-20	1-9/16	.875	.995-1000	.750	7/8	1-1/8	1-3/16	.625	.715-.720	.500	1-29/64	45/64

# MALE BRANCH TEES

# 60

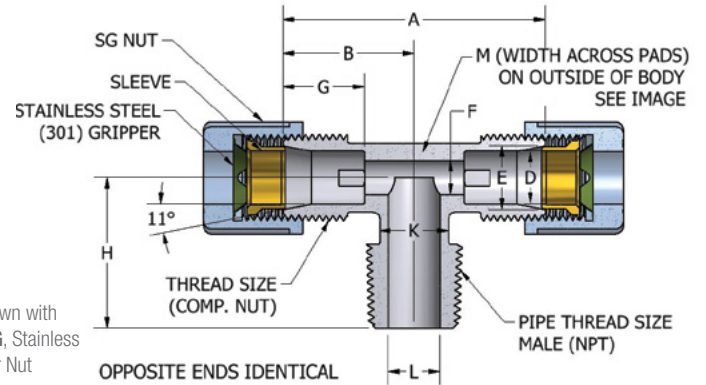

Diagram shown with Nut Style, SG, Stainless Steel Gripper Nut

## Male Branch Tees

JACO Part No.	Tube O.D.	Pipe Thd. NPT	Comp. Thd.	A	B	D	E	F	G	H	K	L	M
Conf. Tube Pipe Mtl. Nut				±1/64	±1/64	+0.005 +.010		±1/64	±1/64	±1/64	±1/64	±1/64	±1/64
60 - 4 - 2 - -	1/4	1/8	7/16-20	1-29/64	47/64	.250	.330-.335	.170	15/32	3/4	3/8	1/4	3/8
60 - 4 - 4 - -	1/4	1/4	7/16-20	1-15/32	47/64	.250	.330-.335	.170	15/32	59/64	3/8	5/16	3/8
60 - 5 - 4 - -	5/16	1/4	1/2-20	1-39/64	13/16	.312	.380-.385	.232	31/64	63/64	7/16	9/32	7/16
60 - 6 - 4 - -	3/8	1/4	5/8-20	1-15/16	31/32	.375	.460-.465	.250	19/32	1-1/16	9/16	5/16	9/16
60 - 6 - 6 - -	3/8	3/8	5/8-20	1-29/32	61/64	.375	.460-.465	.250	19/32	1-3/32	1/2	3/8	1/2
60 - 8 - 6 - -	1/2	3/8	3/4-20	2-13/64	1-7/64	.500	.590-.595	.375	11/16	1-5/32	43/64	25/64	43/64
60 - 8 - 8 - -	1/2	1/2	3/4-20	2-7/32	1-1/8	.500	.590-.595	.375	11/16	1-21/64	5/8	31/64	39/64
60 - 10 - 8 - -	5/8	1/2	7/8-20	2-17/32	1-1/4	.325	.715-.720	.500	45/64	1-7/16	13/16	1/2	13/16
60 - 12 - 8 - -	3/4	1/2	1-1/16-20	3-7/64	1-9/16	.750	.860-.865	.625	13/16	1-41/64	1-1/16	9/16	1-1/16
60 - 12 - 12 - -	3/4	3/4	1-1/16-20	3-7/64	1-9/16	.750	.860-.965	.625	13/16	1-41/64	1-1/16	11/16	1-1/16
60 - 14 - 12 - -	7/8	3/4	1-3/16-16	3-3/32	1-35/64	.875	.955-1.000	.750	7/8	1-5/8	1-3/16	11/16	1-3/16