

# UNION TEES

# 70

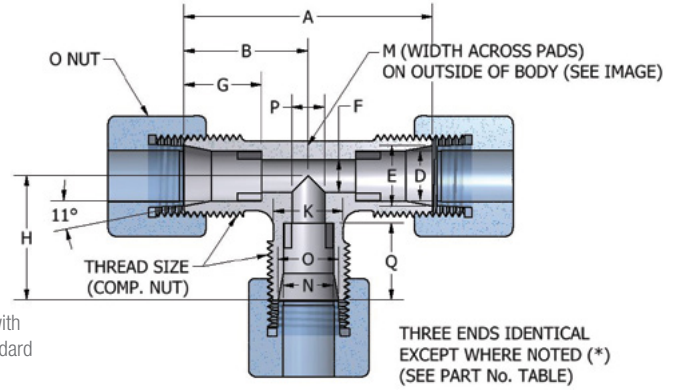
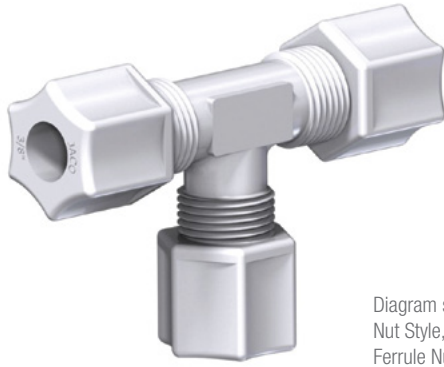

Diagram shown with Nut Style, O, Standard Ferrule Nut

## Union Tees

JACO Part No.	Tube O.D.	Comp. Thd.	A	B	D	E	F	G	H	K	M	N	O	P	Q
<b>Conf.</b>	<b>Tube</b>	<b>Mtl.</b>													
<b>70 - 2 - - - -</b>	1/8	5/16-24	±1/64	±1/64	+005	+005									
<b>70 - 4 - - - -</b>	1/4	7/16-20	±1/64	±1/64	+010	-000	±1/64	±1/64	±1/64	±1/64	±1/64	+005	+005	±010	±1/64
<b>70 - 5 - - - -</b>	5/16	1/2-20	±1/64	±1/64	+010	-000	±1/64	±1/64	±1/64	±1/64	±1/64	+010	-000	±010	±1/64
<b>70 - 6 - - - -</b>	3/8	5/8-20	±1/64	±1/64	+010	-000	±1/64	±1/64	±1/64	±1/64	±1/64	+010	-000	±010	±1/64
<b>70 - 8 - - - -</b>	1/2	3/4-20	±1/64	±1/64	+010	-000	±1/64	±1/64	±1/64	±1/64	±1/64	+010	-000	±010	±1/64
<b>70 - 10 - - - -</b>	5/8	7/8-20	±1/64	±1/64	+010	-000	±1/64	±1/64	±1/64	±1/64	±1/64	+010	-000	±010	±1/64
<b>70 - 12 - - - -</b>	3/4	1-1/16-20	±1/64	±1/64	+010	-000	±1/64	±1/64	±1/64	±1/64	±1/64	+010	-000	±010	±1/64
<b>70 - 14 - - - -</b>	7/8	1-3/16-16	±1/64	±1/64	+010	-000	±1/64	±1/64	±1/64	±1/64	±1/64	+010	-000	±010	±1/64
<b>*70-10-6-M-N</b>	5/8-3/8	7/8-20-5/8-20	±1/64	±1/64	+010	-000	±1/64	±1/64	±1/64	±1/64	±1/64	+010	-000	±010	±1/64
<b>*70-14-10-M-N</b>	7/8-5/8	1-3/16-16-7/8-20	±1/64	±1/64	+010	-000	±1/64	±1/64	±1/64	±1/64	±1/64	+010	-000	±010	±1/64
<b>*70-14-10-10-M-N</b>	7/8-5/8	1-3/16-16-7/8-20	±1/64	±1/64	+010	-000	±1/64	±1/64	±1/64	±1/64	±1/64	+010	-000	±010	±1/64

\*Note: M= Material Selection, N=Nut Selection

# MALE RUN TEES

# 75

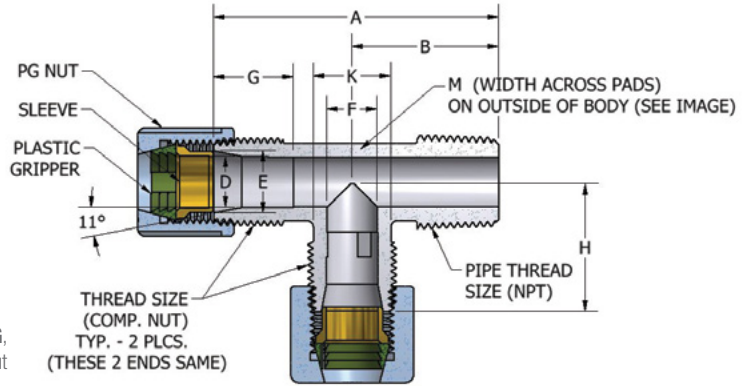

Diagram shown with Nut Style, PG, Plastic Gripper Nut

## Male Run Tees

JACO Part No.	Tube O.D.	Pipe Thd. NPT	Comp. Thd.	A	B	D	E	F	G	H	K	M
<b>Conf.</b>	<b>Tube</b>	<b>Pipe</b>	<b>Mtl.</b>									
<b>75 - 4 - 2 - - -</b>	1/4	1/8	7/16-20	±1/64	±1/64	+005						
<b>75 - 4 - 4 - - -</b>	1/4	1/4	7/16-20	±1/64	±1/64	+010		±010	±1/64	±1/64	±1/64	±1/64
<b>75 - 5 - 4 - - -</b>	5/16	1/4	1/2-20	±1/64	±1/64	+010		±010	±1/64	±1/64	±1/64	±1/64
<b>75 - 6 - 4 - - -</b>	3/8	1/4	5/8-20	±1/64	±1/64	+010		±010	±1/64	±1/64	±1/64	±1/64
<b>75 - 6 - 6 - - -</b>	3/8	3/8	5/8-20	±1/64	±1/64	+010		±010	±1/64	±1/64	±1/64	±1/64
<b>75 - 8 - 6 - - -</b>	1/2	3/8	3/4-20	±1/64	±1/64	+010		±010	±1/64	±1/64	±1/64	±1/64
<b>75 - 8 - 8 - - -</b>	1/2	1/2	3/4-20	±1/64	±1/64	+010		±010	±1/64	±1/64	±1/64	±1/64
<b>75 - 10 - 8 - - -</b>	5/8	1/2	7/8-20	±1/64	±1/64	+010		±010	±1/64	±1/64	±1/64	±1/64
<b>75 - 12 - 8 - - -</b>	3/4	1/2	1-1/16-20	±1/64	±1/64	+010		±010	±1/64	±1/64	±1/64	±1/64
<b>75 - 12 - 12 - - -</b>	3/4	3/4	1-1/16-20	±1/64	±1/64	+010		±010	±1/64	±1/64	±1/64	±1/64
<b>75 - 14 - 12 - - -</b>	7/8	3/4	1-3/16-16	±1/64	±1/64	+010		±010	±1/64	±1/64	±1/64	±1/64