

Wallace & Tiernan[®]
an eVOQUA brand

S10K V-NOTCH CHLORINATOR

BOOK NO. WT.025.200.001.UA.IM.0614

S10K V-NOTCH CHLORINATOR

BOOK NO. WT.025.200.001.UA.IM.0614

S10K V-NOTCH CHLORINATOR

EQUIPMENT SERIAL NO. _____

DATE OF START-UP _____

START-UP BY _____

Prompt service available from nationwide authorized service contractors.

ORDERING INFORMATION

In order for us to fill your order immediately and correctly, please order material by description and part number, as shown in this book. Also, please specify the serial number of the equipment on which the parts will be installed.

WARRANTY

Seller warrants for a period of one year after shipment that the equipment or material of its manufacture is free from defects in workmanship and materials. Corrosion or other decomposition by chemical action is specifically excluded as a defect covered hereunder, except this exclusion shall not apply to chlorination equipment. Seller does not warrant (a) damage caused by use of the items for purposes other than those for which they were designed, (b) damage caused by unauthorized attachments or modifications, (c) products subject to any abuse, misuse, negligence or accident, (d) products where parts not made, supplied, or approved by Seller are used and in the sole judgment of the Seller such use affects the products' performance, stability or reliability, and (e) products that have been altered or repaired in a manner in which, in the sole judgment of Seller, affects the products' performance, stability or reliability. **SELLER MAKES NO OTHER WARRANTY OF ANY KIND, AND THE FOREGOING WARRANTY IS IN LIEU OF ALL OTHER WARRANTIES, EXPRESS OR IMPLIED, INCLUDING ANY WARRANTY OF MERCHANTABILITY OR OF FITNESS OF THE MATERIAL OR EQUIPMENT FOR ANY PARTICULAR PURPOSE EVEN IF THAT PURPOSE IS KNOWN TO SELLER.** If Buyer discovers a defect in material or workmanship, it must promptly notify Seller in writing; Seller reserves the right to require the return of such defective parts to Seller, transportation charges prepaid, to verify such defect before this warranty is applicable. In no event shall such notification be received by Seller later than 13 months after the date of shipment. No action for breach of warranty shall be brought more than 15 months after the date of shipment of the equipment or material.

LIMITATION OF BUYER'S REMEDIES. The **EXCLUSIVE REMEDY** for any breach of warranty is the replacement f.o.b. shipping point of the defective part or parts of the material or equipment. Any equipment or material repaired or replaced under warranty shall carry the balance of the original warranty period, or a minimum of three months. Seller shall not be liable for any liquidated, special, incidental or consequential damages, including without limitation, loss of profits, loss of savings or revenue, loss of use of the material or equipment or any associated material or equipment, the cost of substitute material or equipment, claims of third parties, damage to property, or goodwill, whether based upon breach of warranty, breach of contract, negligence, strict tort, or any other legal theory; provided, however, that such limitation shall not apply to claims for personal injury.

Statements and instructions set forth herein are based upon the best information and practices known to Evoqua Water Technologies, but it should not be assumed that every acceptable safety procedure is contained herein. Of necessity this company cannot guarantee that actions in accordance with such statements and instructions will result in the complete elimination of hazards and it assumes no liability for accidents that may occur.



725 Wooten Road
Colorado Springs, Co 80915

S10K V-NOTCH CHLORINATOR

INTRODUCTION

The Evoqua Water Technologies V-Notch Gas Feeder (Chlorine) described in this instruction book has been designed to meter and control the flow of chlorine gas. An injector accepts this flow of gas, mixes it with water and delivers the resultant solution to the point of application. The gas feeder consists of a control unit, vacuum regulator and a remote injector. Gas feed rate is either manually adjusted by the operator, or automatically adjusted by an electric positioner and electronic controller, and is indicated by a rotameter. Operation is controlled by starting and stopping the flow of water through the injector. The feed rate will vary only in response to the control setting. The rotameter scale permits a direct reading of the rate of gas feed in pounds per 24 hours (or kg/hour) and an adjustment is provided to permit setting the feed rate at any value within the range of the gas feeder. The vacuum regulator, electric positioner and electronic controller are covered in separate books furnished with the equipment.

For swimming pool, water park, or similar non-residential recreational applications, contact your Evoqua Water Technologies Representative for information concerning specific systems designed for such use.



WARNING: HAZARDOUS GAS IS PRESENT IN THIS EQUIPMENT DURING NORMAL OPERATION. TO AVOID POSSIBLE SEVERE PERSONAL INJURY OR DAMAGE TO THE EQUIPMENT, READ THIS INSTRUCTION BOOK AND THE APPROPRIATE GAS MANUAL BEFORE CONNECTING THIS EQUIPMENT TO A SUPPLY OF GAS. OPERATION AND MAINTENANCE OF THIS EQUIPMENT MUST BE RESTRICTED TO TRAINED, QUALIFIED PERSONNEL WHO ARE COMPLETELY FAMILIAR WITH THESE INSTRUCTIONS. CONSULT FACTORY FOR APPLICATIONS AGAINST A NEGATIVE HEAD (PARTIAL VACUUM) OR A POSITIVE BACKPRESSURE OF LESS THAN 1.0 PSI (28 INCHES OF WATER) IN THE SOLUTION DISCHARGE LINE.

NOTE: When ordering material always specify model and serial number of apparatus.

S10K V-NOTCH CHLORINATOR

TABLE OF CONTENTS

Very Important Safety Precautions.....	SP-1,-2
Very Important Safety Precautions.....	1.010-40,-41
Preventive Maintenance General Information	1.010-5
Maintenance Record Card	1.010-13
Regional Offices	1.010-1
Technical Data.....	Section 1
Installation	Section 2
Operation	Section 3
Service	Section 4
Illustrations.....	Section 5
Preventive Maintenance Kits.....	Section 6
Literature/Manuals.....	Section 7
Chlorine Handling Manual.....	WT.025.000.001.UA.IM

S10K V-NOTCH CHLORINATOR

VERY IMPORTANT SAFETY PRECAUTIONS

This page provides very important safety information related to safety in installation, operation, and maintenance of this equipment.

WARNING

TO AVOID POSSIBLE SEVERE PERSONAL INJURY OR EQUIPMENT DAMAGE, OBSERVE THE FOLLOWING:

THIS EQUIPMENT SHOULD BE INSTALLED, OPERATED AND SERVICED ONLY BY TRAINED, QUALIFIED PERSONNEL WHO ARE THOROUGHLY FAMILIAR WITH THE ENTIRE CONTENTS OF THIS INSTRUCTION BOOK.

THE CONTROL UNIT IS DESIGNED TO OPERATE UNDER VACUUM ONLY. DO NOT CONNECT TO A SOURCE OF GAS UNDER PRESSURE.

THE GAS FEEDER MUST BE VENTED TO A TREATMENT SYSTEM OR OUTSIDE ATMOSPHERE. THE VENT LINE MUST TERMINATE IN AN AREA WHERE GAS FUMES CANNOT CAUSE INJURY TO PERSONNEL OR DAMAGE TO EQUIPMENT. DO NOT TERMINATE THE VENT LINE AT A LOCATION ROUTINELY USED BY PERSONNEL, SUCH AS WORK AREAS OR PATHWAYS, NOR NEAR WINDOWS OR VENTILATION SYSTEM INTAKES.

SHUT OFF GAS SUPPLY AT THE GAS SUPPLY CONTAINER VALVE. OPERATE THE INJECTOR WITH THE GAS SUPPLY TURNED OFF UNTIL THE GRAY KNOB DROPS DOWN AND THE COLOR INDICATOR ON THE FRONT OF THE VACUUM REGULATOR TURNS RED, AND THE ROTAMETER FLOAT SETTLES ON BOTTOM STOP, THEN TURN OFF THE INJECTOR WATER SUPPLY.

IF A MANUAL CONTROL UNIT IS MOUNTED ON A VACUUM REGULATOR, THE VACUUM REGULATOR MUST HAVE BUILT-IN PRESSURE RELIEF.

GAS CYLINDERS MUST BE SECURED IN SUCH A MANNER (e.g. CHAIN) AS TO PREVENT THEIR BEING KNOCKED OVER.

DO NOT USE HYDROCARBONS OR ALCOHOLS BECAUSE RESIDUAL SOLVENT MAY REACT WITH GAS. SOLVENTS CAN PRODUCE SERIOUS PHYSIOLOGICAL EFFECTS UNLESS USED IN STRICTEST COMPLIANCE WITH THE SOLVENT MANUFACTURER'S SAFETY RECOMMENDATIONS.

WHEN USING HYDROCHLORIC ACID, OBSERVE ALL SAFETY PRECAUTIONS RECOMMENDED BY THE ACID MANUFACTURER/SUPPLIER.

DO NOT DISCARD THIS INSTRUCTION BOOK UPON COMPLETION OF INSTALLATION. INFORMATION PROVIDED IS ESSENTIAL TO PROPER AND SAFE OPERATION AND MAINTENANCE.



S10K V-NOTCH CHLORINATOR



VERY IMPORTANT SAFETY PRECAUTIONS (CONT'D)

ADDITIONAL OR REPLACEMENT COPIES OF THIS INSTRUCTION BOOK ARE AVAILABLE FROM:

Evoqua Water Technologies
725 Wooten Road
Colorado Springs, CO 80915
Phone: (800) 524-6324

NOTE

Minor part number changes may be incorporated into Evoqua Water Technologies products from time to time that are not immediately reflected in the instruction book. If such a change apparently has been made in your equipment and does not appear to be reflected in your instruction book, contact your local Evoqua Water Technologies sales office for information.

Please include the equipment serial number in all correspondence. It is essential for effective communication and proper equipment identification.

S10K V-NOTCH CHLORINATOR

VERY IMPORTANT SAFETY PRECAUTIONS - CHLORINE

This page provides very important safety information related to safety in installation, operation, and maintenance of this equipment.

WARNING

TO AVOID POSSIBLE SEVERE PERSONAL INJURY OR EQUIPMENT DAMAGE, OBSERVE THE FOLLOWING:

THIS EQUIPMENT SHOULD BE INSTALLED, OPERATED, AND SERVICE ONLY BY TRAINED, QUALIFIED PERSONNEL WHO ARE THOROUGHLY FAMILIAR WITH THE ENTIRE CONTENTS OF THIS INSTRUCTION BOOK AND THE CHLORINE GAS HANDLING MANUAL.

CHLORINE GAS IS A RESPIRATORY IRRITANT. EXPOSURE TO CHLORINE GAS IN SUFFICIENT CONCENTRATION PRODUCES IRRITATION OF THE MUCOUS MEMBRANES, THE RESPIRATORY SYSTEM, AND THE SKIN. IN EXTREME CASES, SUFFOCATION AND DEATH CAN OCCUR.

WHEN CHANGING CHLORINE CYLINDERS, IT IS RECOMMENDED PRACTICE TO HAVE AN APPROVED GAS MASK AVAILABLE THAT YOU HAVE BEEN TRAINED TO USE AND YOU MUST BE COMPLETELY FAMILIAR WITH YOUR LOCAL PLANT OPERATING AND EMERGENCY PROCEDURES AND CHLORINE INSTITUTE RECOMMENDED EMERGENCY PROCEDURES.

DO NOT TOLERATE ANY CHLORINE LEAKS. CHLORINE LEAKS NEVER GET BETTER. CHLORINE LEAKS ALWAYS GET PROGRESSIVELY WORSE IF THEY ARE NOT PROMPTLY CORRECTED. IT IS RECOMMENDED PRACTICE TO HAVE AN APPROVED GAS MASK AVAILABLE WHEN MAKING LEAK CHECKS.

AS SOON AS THERE IS ANY INDICATION OF CHLORINE IN THE AIR, TAKE IMMEDIATE STEPS TO CORRECT THE CONDITION.

IMPORTANT INFORMATION RELATED TO SAFETY OF CHLORINATION EQUIPMENT INSTALLATION IS PROVIDED IN THE CHLORINE GAS HANDLING MANUAL. IN THE INTEREST OF SAFE OPERATION, THIS INFORMATION MUST BE READ, UNDERSTOOD, AND PRACTICED BY EQUIPMENT OPERATORS AND THEIR SUPERVISORS.

AT TIME OF INITIAL INSTALLATION, WHEN CHLORINE SUPPLY LINES HAVE BEEN DISCONNECTED FOR ANY REASON AND ON A ROUTINE DAILY BASIS, THOROUGHLY CHECK ALL JOINTS, CONNECTIONS, AND EQUIPMENT FOR POSSIBLE CHLORINE LEAKS AND IMMEDIATELY CORRECT ANY THAT MAY BE FOUND.

WHEN ANY CONNECTION IS BROKEN EVEN FOR A SHORT TIME, IMMEDIATELY PLUG THE RESULTANT OPENINGS WITH A RUBBER STOPPER OR EQUIVALENT TO PREVENT THE ENTRANCE OF MOISTURE. MOISTURE MUST BE EXCLUDED FROM ANY PART OF THE EQUIPMENT THAT IS NORMALLY EXPOSED TO DRY CHLORINE ONLY. WHILE DRY CHLORINE IS NON-CORROSIVE, MOIST CHLORINE IS EXTREMELY CORROSIVE TO COMMON METALS, SUCH AS BRASS OR STEEL.

S10K V-NOTCH CHLORINATOR

VERY IMPORTANT SAFETY PRECAUTIONS - CHLORINE (CONT'D)

THE TWO MOST COMMON CAUSES OF CHLORINE PIPING LEAKS ARE:

1. RE-USE OF GASKETS. THIS SHOULD NEVER BE DONE. ALWAYS HAVE AN ADEQUATE SUPPLY ON HAND AND ALWAYS USE NEW GASKETS OF THE CORRECT MATERIAL AND SIZE AS IDENTIFIED ON THE EQUIPMENT PARTS DRAWING.
2. IMPROPERLY MADE-UP THREADED PIPE JOINTS. SEE CHLORINE GAS HANDLING MANUAL FOR RECOMMENDED PROCEDURE.

EXCEPT IN CASES OF LEAK DETECTION OR CALIBRATION ADJUSTMENTS, THE CHLORINE GAS SUPPLY MUST BE SHUT OFF AT THE GAS SUPPLY CONTAINERS AND THE CHLORINE GAS IN THE SYSTEM EXHAUSTED BEFORE SERVICING THE EQUIPMENT.

USE ONLY EVOQUA WATER TECHNOLOGIES LISTED PARTS, EXCEPT FOR COMMERCIALY AVAILABLE PARTS AS IDENTIFIED ON THE PARTS LIST. THE USE OF UNLISTED PARTS CAN RESULT IN EQUIPMENT MALFUNCTIONS HAVE HAZARDOUS CONSEQUENCES.

DO NOT DISCARD THIS INSTRUCTION BOOK UPON COMPLETION OF INSTALLATION. INFORMATION PROVIDED IS ESSENTIAL TO PROPER AND SAFE OPERATION AND MAINTENANCE.

ADDITIONAL OR REPLACEMENT COPIES OF THIS INSTRUCTION BOOK ARE AVAILABLE FROM:

Evoqua Water Technologies
725 Wooten Road
Colorado Springs, CO 80915
Phone: (800) 524-6324

NOTE

Minor part number changes may be incorporated into Evoqua Water Technologies products from time to time that are not immediately reflected in the instruction book. If such a change apparently has been made in your equipment and does not appear to be reflected in your instruction book, contact your local Evoqua Water Technologies sales office for information.

Please include the equipment serial number in all correspondence. It is essential for effective communication and proper equipment identification.

S10K V-NOTCH CHLORINATOR



PROTECT YOUR EQUIPMENT INVESTMENT

MINIMIZE DOWNTIME

**ORDER A PREVENTIVE MAINTENANCE KIT NOW ...
KEEP ONE ON HAND**

Quality Equipment	+	Preventive Maintenance	=	Dependable Operation Minimum Downtime
------------------------------	----------	-----------------------------------	----------	--

There's no question about it.

Equipment that is properly maintained is dependable equipment.
It will give optimum performance with minimum unscheduled downtime.

Evoqua Water Technologies manufactures quality equipment designed for performance and reliability. Each product is carefully tested and inspected before shipment to ensure that it meets our high standards.

Our equipment is engineered for easy maintenance. To ensure maximum service life and minimize unscheduled repairs, we recommend a program of regular preventive maintenance, as described in the Service section of this book. To support this program, we developed standard parts kits. These kits can also be used for minor emergency repairs to minimize downtime.

We recommend that these kits be available in your stock at all times. When the complete kit or any of its parts are used, the kit should be replaced immediately.

Preventive maintenance kits may be ordered directly from the company that supplied your equipment, or they may be ordered directly from Evoqua Water Technologies. For ordering numbers, refer to the parts list at the rear of this book.

S10K V-NOTCH CHLORINATOR

PREVENTIVE MAINTENANCE SCHEDULE AND RECORD OF PERFORMANCE

This equipment should receive preventive maintenance on a one (1) year cycle.* It is recommended that the following table be used to plan, schedule, and record this important work.

Date of Installation	
-----------------------------	--

Preventive Maintenance Log	
Schedule Date	Date Performed

***NOTE:** This is the recommended cycle. Your local operating conditions may call for more frequent preventive maintenance.



PROTECT YOUR EQUIPMENT INVESTMENT

MINIMIZE DOWNTIME

**ORDER A PREVENTIVE MAINTENANCE KIT NOW ...
KEEP ONE ON HAND**

S10K V-NOTCH CHLORINATOR

REGIONAL OFFICES

INSTALLATION, OPERATION, MAINTENANCE, AND SERVICE INFORMATION

Direct any questions concerning this equipment that are not answered in the instruction book to the Reseller from whom the equipment was purchased. If the equipment was purchased directly from Evoqua Water Technologies, Colorado Springs, CO contact the office indicated below.

UNITED STATES

725 Wooten Road
Colorado Springs, CO 80915
TEL: (800) 524-6324

CANADA

If the equipment was purchased directly from Evoqua Water Technologies, Canada, contact the nearest office indicated below.

ONTARIO

Evoqua Water Technologies Ltd.
2045 Drew Road
Mississauga, Ontario
L5S 1S4
(905) 944-2800

QUEBEC

Evoqua Technologies des Eaux Itée
505 Levy Street
St. Laurent, Quebec
H4R 2N9
(450) 582-4266



S10K V-NOTCH CHLORINATOR

S10K V-NOTCH CHLORINATOR

SECTION 1 - TECHNICAL DATA

List Of Contents

	PARA./DWG. NO.
General	1.1
Application Data	1.2
Technical Data	1.3
Illustrations	
Identification - Vacuum Regulator Switchover	25.210.150.010
Performance.....	25.052.190.030
Performance.....	910.200.196.020

S10K V-NOTCH CHLORINATOR

1.1 General

The gas feeder can be used with either the standard vacuum regulator or two automatic switchover vacuum regulators. The vacuum regulator can be connected to a supply cylinder, ton container, five-tank manifold or a ten-tank manifold (see separate instruction book for installation procedures). The gas feeder can be used with either a standard injector or an anti-syphon injector. An electric positioner is used with either a flow proportional or a residual electronic controller.

1.2 Application

Control of the feed rate may be manual, start-stop, or electric.

Both the standard and anti-syphon injectors are mounted remotely from the control unit. The manual control unit can be mounted on a vacuum regulator, if desired.

1.3 Technical Data

Accuracy:	4% of indicated flow
Capacities:	1.2 to 500 lb/24 hr chlorine
Feed Range:	Manual: 20 to 1 for any one rotameter Automatic: 10 to 1 for any one V-notch plug
Injector Operating Water Supply:	300 psi maximum at 100°F maximum 150 psi maximum at 130°F maximum
Pressure (at point of application):	75 psi max with flexible polyethylene (160 psi max with high pressure hose or rigid pipe) for the solution line.
Recommended Operating Vacuum at Control Unit:	16 in. Hg
Ambient Temperature:	35 to 130°F (2 to 55°C)

S10K V-NOTCH CHLORINATOR

Identify maximum capacity by housing: 210 or 510?

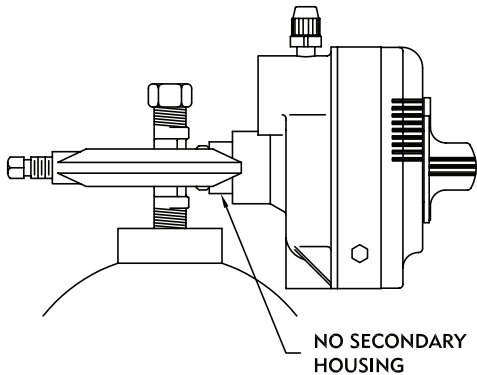

210
NO SECONDARY HOUSING

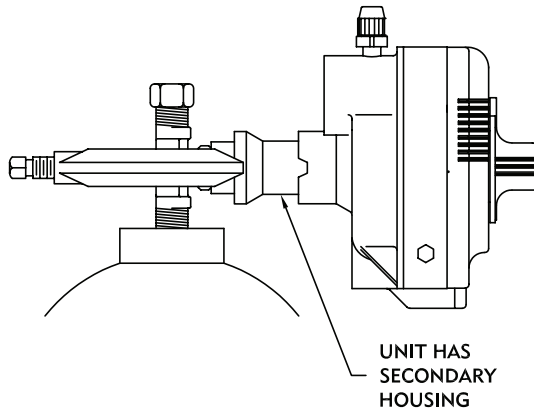

510
WITH SECONDARY HOUSING

Identify switchover by cover icons: Auto or Standard?

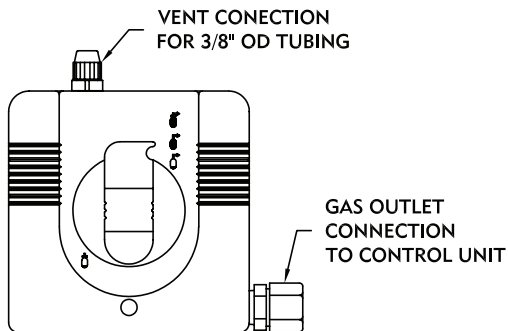

AUTO SWITCHOVER

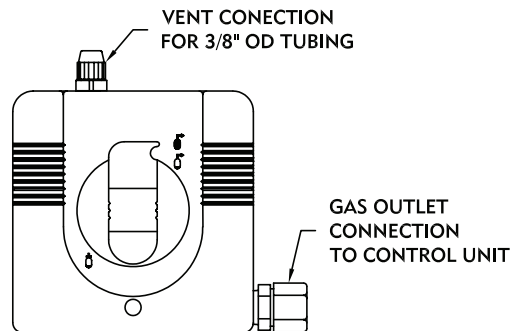

STANDARD

VACUUM REGULATOR SWITCHOVER - IDENTIFICATION

25.210.150.010

ISSUE 1 12-07

S10K V-NOTCH CHLORINATOR

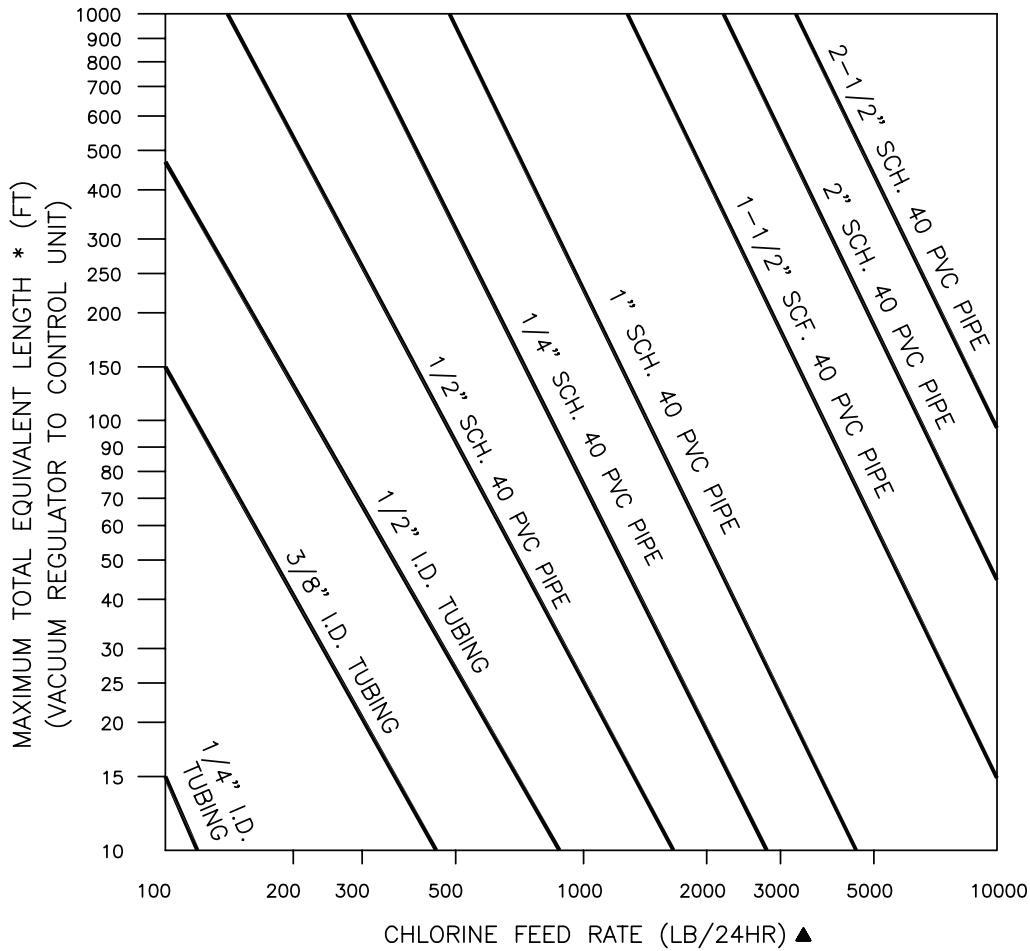

APPROXIMATE FRICTION LOSS IN PVC PIPE
FITTING IN EQUIVALENT FEET OF PIPE:

NOMINAL PIPE SIZE, IN.	1/2	3/4	1	1-1/2	2	2-1/2
TEE, SIDE OUTLET	4	5	6	8	12	15
90° ELBOW	1-1/2	2	2-3/4	4	6	8
45° ELBOW	3/4	1	1-3/8	2	2-1/2	3

NOTE:

* TOTAL EQUIVALENT LENGTH = PIPE LENGTH PLUS EQUIVALENT LENGTH FOR EACH FITTING. SEE TABLE ABOVE. 1.) WITH AUTOMATIC SWITCHOVER VACUUM REGULATORS, USE THE LENGTH OF THE LONGER OF THE TWO VACUUM LINES, NOT BOTH, TO DETERMINE TOTAL LENGTH. 2.) TO KEEP THE PRESSURE LOSS WITHIN PERMISSIBLE LIMITS, A COMBINATION OF PIPE SIZES MAY BE USED. IF THIS IS DONE, FOR A GIVEN FLOW, THE LOSS THROUGH EACH FOOT OF 1/2" SCH. 40 PVC PIPE IS EQUIVALENT TO THE LOSS THROUGH : A.) 3FT. OF 3/4" SCH. 40 PVC PIPE; B.) 8 FT. OF 1" SCH. 40 PVC PIPE; C.) 45FT. OF 1-1/2" SCH. 40 PVC PIPE; D.) 122 FT. OF 2" SCH. 40 PVC PIPE; E.) 248 FT. OF 2-1/2" SCH. 40 PVC PIPE.

▲ FOR GASES OTHER THAN CHLORINE, USE THE FOLLOWING APPROXIMATE CONVERSIONS:
 CHLORINE FEED RATE = SULFUR DIOXIDE FEED RATE (LB/24HR.)
 = 2.1 X AMMONIA FEED RATE (LB/24HR.)
 = 1.3 X CARBON DIOXIDE FEED RATE (LB/24HR.)

VACUUM LINE LENGTH LIMITS - PERFORMANCE Used In Remote Vacuum Gas Feeders

25.052.190.030

ISSUE 3 5-97

S10K V-NOTCH CHLORINATOR

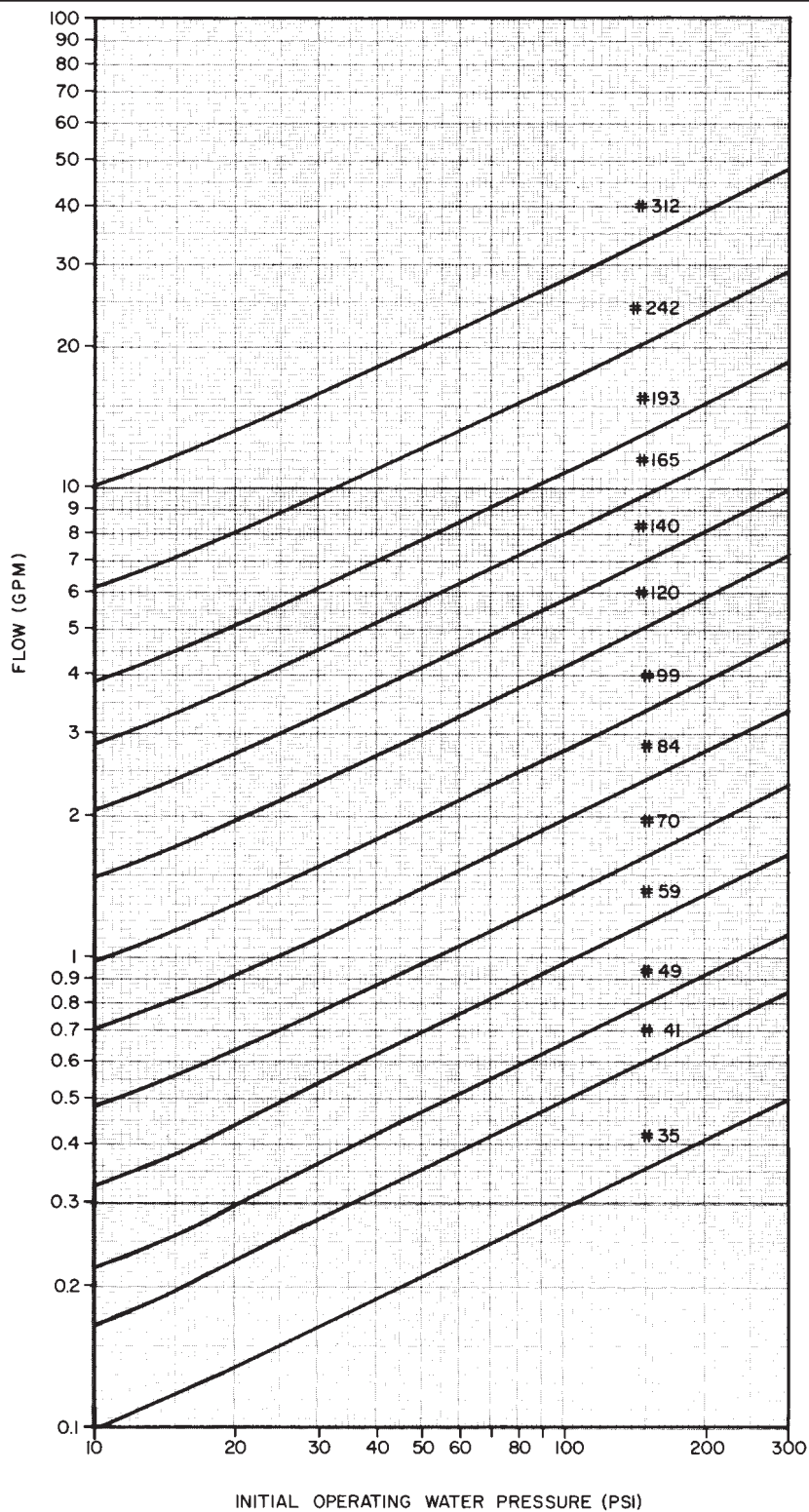

NOTE: NO SAFETY FACTOR INCLUDED.

INJECTOR OPERATING WATER - PERFORMANCE
Fixed Throat Injectors

910.200.196.020

ISSUE 4 11-84



S10K V-NOTCH CHLORINATOR

SECTION 2

S10K V-NOTCH CHLORINATOR

SECTION 2 - INSTALLATION

List Of Contents

	PARA./DWG. NO.
General	2.1
Unpacking.....	2.2
Location.....	2.3
Rotameter	2.4
Vent	2.5
Electrical Connections	2.6
Injector Suction Connection.....	2.7
Injector Water Supply.....	2.8
Drain	2.9
Injector Discharge.....	2.10
Point of Application	2.11
Vacuum Regulator	2.12
Injector	2.13
Leak Check.....	2.14
Manual Control Unit.....	2.14.1
Automatic Control Unit	2.14.2
Interconnection of Components	2.15
Illustrations	
Typical Installation	
S10K Gas Feeder (Automatic)	25.200.110.010
S10K Gas Feeder (Manual).....	25.200.110.020
S10K Gas Feeder	25.200.110.030
S10K Gas Feeder	25.200.110.040
S10K Gas Feeder	25.200.110.050
Connections to Points of Application	25.200.110.060A&B
Component Interconnection.....	25.200.110.080
Dimensions	
Rotameter Housings.....	25.200.100.050
Automatic Control Panel	25.200.100.060
Installation.....	50.830.110.011

2.1 General



WARNING: THE CONTROL UNIT IS DESIGNED TO OPERATE UNDER VACUUM ONLY. TO AVOID POSSIBLE SEVERE PERSONAL INJURY OR EQUIPMENT DAMAGE, DO NOT CONNECT TO A SOURCE OF GAS UNDER PRESSURE.

The general physical requirements of the installation are shown on the TYPICAL INSTALLATION drawings. Locate the control unit so that the necessary gas and power supplies may be connected. Ready access to the control unit for operation, routine maintenance, and service is required. Locate the injector so that the water supply, solution line to the point of application, and suction lines may be connected and access for service may be conveniently provided. A floor drain in the injector area is desirable.

2.2 Unpacking

When the equipment and accessory items are unpacked, check all items against the packing list to be sure that no parts are discarded with the packing material. Whenever possible, unpack the equipment at the installation site. Items such as spare parts not required at the time of installation should be set aside where they will be available when needed.

NOTE: Do not discard or remove this instruction book when the installation is completed. The operator will need it.

2.3 Location (See Dwgs. 25.200.110.010, .020, .030, .040 and .050)



CAUTION: Before any attempt is made to place the equipment into operation, the operator should be familiar with the characteristics of chlorine. Important information on this subject is provided in the Chlorine Handling Manual attached to the rear of this instruction book. This information should be studied carefully before the gas feeder is prepared for operation.

A site for the gas feeder must be provided which will:

- Exclude unauthorized persons from the installation.
- Furnish storage space for and protect the in-use and reserve gas cylinders from falling over, from the weather and from direct sunlight or extremes of temperature - not colder than 35°F (2°C) or warmer than 130°F (55°C).
- Provide a vertical surface for mounting the control unit(s), unless mounted on the vacuum regulator.
- Permit access to the injector(s).

S10K V-NOTCH CHLORINATOR

- Provide space, support, and electric power for a booster pump and alarm system if required.
- Allow adequate working space for routine servicing.

2.4 Rotameter (See Dwgs. 25.200.001.010 and 25.200.001.020)

NOTE: For protection in shipment, the rotameter and associated parts were removed after the control unit was factory tested. These parts are separately packaged and should be assembled and installed as indicated.

Install the rotameter as follows:

- Insert an open end wrench or similar tool into the slot in the bottom of the rotameter jack-screw. (See Figure 2.1.) Unscrew it, counterclockwise from the bottom. Remove the rotameter jack-screw.
- Insert one gasket in the top of the rotameter frame.
- Insert lower stop, float and top stop into rotameter tube.
- Carefully raise the rotameter tube with installed parts into the frame.
- Insert the O-ring on top of the rotameter jack-screw.

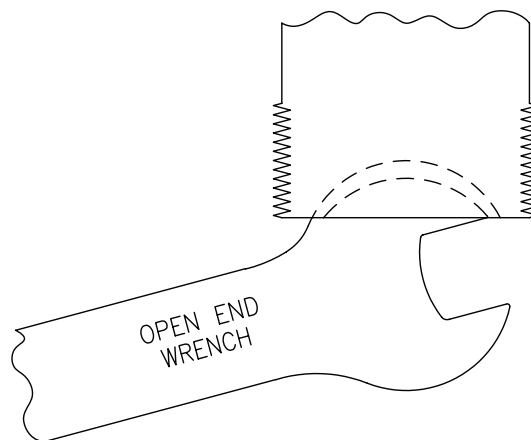

Figure 2.1

- Engage the rotameter jack-screw in its threaded opening and tighten by hand.
- Tighten the rotameter jack-screw gently with wrench until a firm seal is achieved.



CAUTION: Do not overtighten as this may break the glass rotameter tube.

2.5 Vent

If a remote pressure relief valve is used, a vent line is required from the half union on the relief valve to a treatment system or a point outside the building where an occasional odor of gas will not be objectionable. The proper installation of this line is important. The gradient of the line must be continuous without traps and down toward atmosphere. Point the atmospheric end down and screen it against the entrance of foreign materials. Where traps are unavoidable or a down gradient is not possible, provisions for condensate removal must be installed at all low points (drip leg). Suitable support for the vent is required throughout its entire length.



WARNING: THE GAS FEEDER MUST BE VENTED TO A TREATMENT SYSTEM OR OUTSIDE ATMOSPHERE. THE VENT LINE MUST TERMINATE IN AN AREA WHERE GAS FUMES CANNOT CAUSE INJURY TO PERSONNEL OR DAMAGE TO EQUIPMENT. DO NOT TERMINATE THE VENT LINE AT A LOCATION ROUTINELY USED BY PERSONNEL, SUCH AS WORK AREAS OR PATHWAYS, NOR NEAR WINDOWS OR VENTILATION SYSTEM INTAKES.

2.6 Electrical Connections

If the gas feeder is furnished with accessories requiring a power supply or wiring to other equipment, appropriate wiring diagrams will be found in the instructions for the accessory items. See the Installation Wiring diagrams for the electronic controller connections in the separate instruction book.

NOTE: Field wiring must conform to local electrical codes.

2.7 Injector Suction Connection

The piping must be sized as required to obtain a minimum of sixteen inches of mercury vacuum at the control unit when feeding gas.



CAUTION: No vacuum relief. To avoid flooding, connect to a differential type injector only.

2.8 Injector Water Supply

The injector requires a supply of reasonably clean water. Equip the water line with a strainer as indicated in the typical installation drawing in this section. The pressure and quantity of water required depends on your operating conditions (backpressure and gas feed rate).

NOTE: For intermittent start-stop operation, flexible polyethylene or rigid PVC pipe is recommended for a minimum of three feet immediately upstream of the injector. This should reduce corrosion of metal pipe and components (valves, pump impellers, etc.) caused by diffusion of solution during shut-down periods.

2.9 Drain

A floor drain is not required, but is always desirable to facilitate injector service.

2.10 Injector Discharge

Rigid PVC pipe or Evoqua Water Technologies solution hose is required between the injector discharge and the point of application. The size depends on the size of the throat and tailway used in the injector. Solution hose may be connected directly to the injector tailway. If rigid PVC pipe is used, a piece of straight pipe at least eight inches long should be coupled to the end of the injector tailway before any elbows, tees or Saunders valves are used. This will prevent any flow disturbances that could affect the hydraulic performance of tailway connections.

2.11 Point of Application

- **Main Connection:** If the solution is to be applied in a main, a suitable pipe tap is required in the main to accommodate the solution tube, corporation cock or diffuser.
- **Open Well:** If the solution is to be applied where there is no pressure, the line from the injector must be supported so that the open end is submerged a minimum of six feet, is located in a nonstagnant area, and best promotes rapid and thorough mixing of the solution into the water.

2.12 Vacuum Regulator

A vacuum regulator is connected to the control unit inlet. Refer to the separate instruction book supplied with the vacuum regulator for installation instructions. Manual control units may be mounted on the vacuum regulators.



WARNING: TO AVOID POSSIBLE SEVERE PERSONAL INJURY OR EQUIPMENT DAMAGE, IF A MANUAL CONTROL UNIT IS MOUNTED ON A VACUUM REGULATOR, THE VACUUM REGULATOR MUST HAVE BUILT-IN PRESSURE RELIEF.

See separate instruction book supplied with the vacuum regulator.

NOTE: The vacuum line extending to the control unit from the vacuum regulator must not exceed the distance as determined through the use of the graph shown on Dwg. 25.052.190.030, for the standard tubing and pipe sizes given. If necessary any size tubing or pipe can be installed which will not give more than five inches of water differential between control unit and vacuum regulator at maximum feed rate. Note that the equivalent length of the fittings must be added to the tubing length to obtain the total equivalent length.

2.13 Injector

The injector is a key component as it must develop the vacuum which makes the rest of the components work.

NOTE: Avoid any downward discharge because air or gas bubbles may accumulate and become trapped in the tailway, interfering with its hydraulic operation.

The injector diaphragm check valve will provide the greatest security against leakage if the injector is installed so that it is self-draining. This can be accomplished by observing the following:

2.13.1 Installing 3/4" Fixed Throat Injector

To install the 3/4-inch fixed throat injector, proceed as follows:

- a. Install the injector tailway (beige color with letter designation) directly into a 3/4-inch NPT in a main which is eight inches or larger in size.



CAUTION: For proper dispersal of solution, the end of the tailway (beige) must extend into main, but not more than 1/3 the diameter of the main.

- b. If the main is smaller than eight inches, install the tailway in a tee, in a run or corner of main.

NOTE: Do not cut off any portion of the tailway. To do so would interrupt flow in the pressure-recovery zone and prevent normal performance.

- c. Where the injector is to be some distance away from the point of application, use adapters to connect to pipe or corporation cock type main connections, check valves, etc. See Dwg. 25.200.110.010. Your distributor can provide whatever components are required.
- d. Where the injector is not installed directly into the application main, wall mounting of the injector may be required. To install the injector on a suitable wall, at the desired location, use the two mounting holes in the injector as the drilling template.
- e. The injector nozzle (black color with number size designation) is designed to accept 3/4-inch polyethylene tubing or 3/4-inch threaded pipe connection. For pipe thread connection, cut off the serrated section and bevel the sharp corners at the ID and OD. Ensure that the interior of the nozzle is free from burrs or chips before installing it in the injector.

NOTE: The polyethylene tubing is suitable for pressures up to 75 psi. Pressure in excess of 75 psi requires rigid pipe. The nozzle and the tailway are sealed to the injector body by means of O-rings. Hand tightening is sufficient. Do not use a wrench or attempt to tighten beyond that point where the shoulder on the fitting touches the body of the injector. If the injector is not oriented as desired when fully installed over the tailway, use a suitable tool to turn the tailway with respect to the main (or next fitting in the assembly) until the orientation is correct.

- f. Install connection to water supply or to a booster pump, if required. The water supply valve can be a manual valve or a solenoid valve. A water supply strainer as shown in Dwg. 25.200.110.010 is recommended. The water supply must be reasonably clean. If the injector is to be operated using clarified effluent, such as in a sewage treatment plant, use larger sizes of nozzles and tailways to minimize the likelihood of plugging.

2.13.2 Installing 1" Fixed Throat Injector

To install the one-inch fixed throat injector, proceed as follows:

NOTE: Do not cut off any portion of the tailway. To do so would interrupt flow in the pressure-recovery zone and prevent normal performance.

- a. Where the injector is to be some distance away from the point of application, use adapters to connect to pipe or corporation cock type main connections, check valves, etc. See Dwg. 25.200.110.010. Your distributor can provide whatever components are required.
- b. Where the injector is not installed directly into the application main, wall mounting of the injector may be required. To install the injector on a suitable wall, at the desired location, use the two mounting holes in the injector as the drilling template.
- c. The injector water inlet is designed to accept one-inch threaded pipe.

NOTE: The nozzle and the tailway are sealed to the injector body by O-rings. Hand tightening of the retaining nut is sufficient.

- d. Install connection to water supply or to a booster pump, if required. The water supply valve can be a manual valve or a solenoid valve. A water supply strainer is recommended. The water supply must be reasonably clean. If the injector is to be operated using clarified effluent, such as in a sewage treatment plant, use larger sizes of nozzles and tailways to minimize the likelihood of plugging.

2.14 Leak Check

After the vacuum regulator(s) is in place and before the gas tubing is installed, check for leaks as directed in the separate instruction book provided with vacuum regulator.



WARNING: TO AVOID POSSIBLE SEVERE PERSONAL INJURY OR EQUIPMENT DAMAGE, DO NOT TOLERATE ANY GAS LEAKS. GAS LEAKS ALWAYS GET PROGRESSIVELY WORSE AND MUST BE CORRECTED PROMPTLY.

2.14.1 Manual Control Unit

The manual control unit may be mounted on the vacuum regulators.

Alternatively, control units are designed to be mounted on a vertical surface (such as a wall or a column) at the height suitable for convenient reading of the rotameter by the operator. This will be typically five feet from the floor to the bottom of the control unit.

NOTE: If the control unit is being bolted to an uneven wall, shims must be added to prevent the control unit from twisting when the bolts are tightened.



CAUTION: The axis of the rotameter in the control unit must be vertical in its mounted position. Use a weighted spring or spirit level to check this.

Make the tube lines from the control units to the injectors as short as practicable. Select the control unit location to achieve this. See Dwg. 25.052.190.030 for maximum permissible lengths of tubing.

See Typical Installation drawings and paragraph 2.15, Interconnection of Components.

2.14.2 Automatic Control Unit

The automatic control unit is designed to be mounted on a vertical surface (such as a wall or a column) at the height suitable for convenient reading of the rotameter by the operator.

NOTE: If the automatic control unit is being bolted to an uneven wall, shims must be added to prevent the panel from twisting when the six bolts are tightened.



CAUTION: The axis of the rotameter in the control unit must be vertical in its mounted position. Use a weighted spring or spirit level to check this.

S10K V-NOTCH CHLORINATOR

Make the tube lines from the vacuum regulator to the control unit(s), and from all control units to injectors, as short as practicable. Select the control unit location to achieve this. See Dwg. 25.052.190.030 for maximum permissible lengths of tubing.

2.15 Interconnection of Components

With the control unit(s), injector(s) and vacuum regulator(s) in place, a system is completed by installing the interconnecting tubing. Support long runs of tubing or pipe in a suitable manner, using tube clips or ties as appropriate to the site. See Typical Installation drawings.

S10K V-NOTCH CHLORINATOR

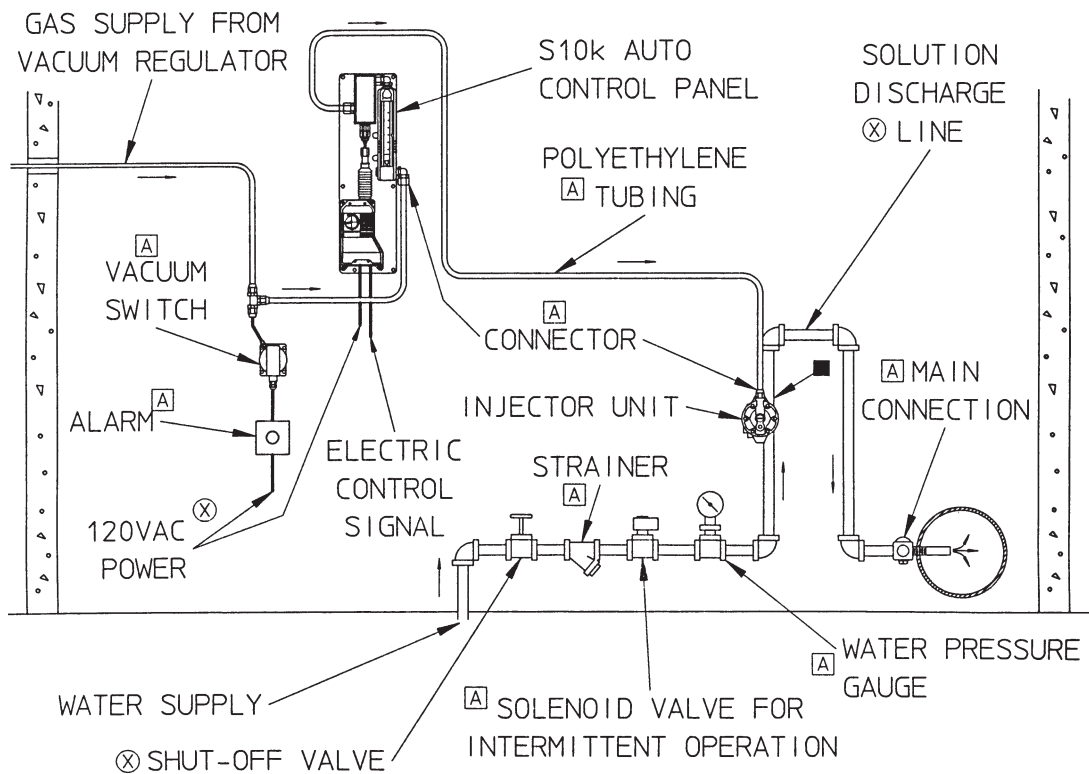

MAXIMUM VACUUM LINE LENGTHS - FROM VACUUM REGULATOR TO CONTROL UNIT					
▲ GAS CAPACITY (LB/24 HR)				1/2" ID TUBING RP68 4503	1/2" SCHEDULE 40 PVC PIPE
Cl ₂	NH ₃	SO ₂	CO ₂		
500	240	475	390	23 FT.	72 FT.
400	190	400	300	35 FT.	108 FT.
300	140	300	230	60 FT.	180 FT.
200	95	200	150	125 FT.	380 FT.
100	45	100	75	450 FT.	ESSENT. UNLTD.
50	24	50	35	ESSENT. UNLTD.	ESSENT. UNLTD.

NOTE: DEDUCT 2 FT. FOR EACH 90° ELBOW USED AND 1 FT. FOR EVERY 4 STRAIGHT FITTINGS (U24102) USED.

NOTE: [A] ACCESSORY ITEM FURNISHED ONLY IF SPECIFICALLY LISTED ON QUOTATION.

(X) NOT FURNISHED BY EVOQUA WATER TECHNOLOGIES.

▲ Cl₂ - CHLORINE, SO₂ - SULFUR DIOXIDE, CO₂ - CARBON DIOXIDE, NH₃ - AMMONIA.

TO DETERMINE MAXIMUM VACUUM LINE LENGTH WHEN TUBING AND PIPER ARE USED IN COMBINATION, EACH FOOT OF 1/2" ID TUBING CAN BE REPLACED WITH:

A) 3.1 FT. OF SCHEDULE 40, 1/2" PVC PIPE. B) 9.5 FT. OF SCHEDULE 40, 3/4" PVC PIPE.

WITH SWITCHOVER VALVES, USE THE LENGTH OF THE LONGER OF TWO VACUUM REGULATOR LINES, NOT BOTH, TO DETERMINE TOTAL LENGTH.

- SOLUTION HOSE MAY BE CONNECTED DIRECTLY TO THE INJECTOR TAILWAY. IF RIGID PVC PIPE IS USED, A PIECE OF STRAIGHT PIPE AT LEAST EIGHT INCHES LONG SHOULD BE COUPLED TO THE END OF THE INJECTOR TAILWAY BEFORE ANY ELBOWS, TEES OR SIMILAR FLOW RESTRICTIONS ARE USED. THIS IS TO PREVENT ANY FLOW DISTURBANCES THAT COULD AFFECT THE HYDRAULIC PERFORMANCE OF TAILWAY CONNECTIONS.

S10K GAS FEEDER (AUTOMATIC) - TYPICAL INSTALLATION

25.200.110.010

ISSUE 2 6-14

S10K V-NOTCH CHLORINATOR

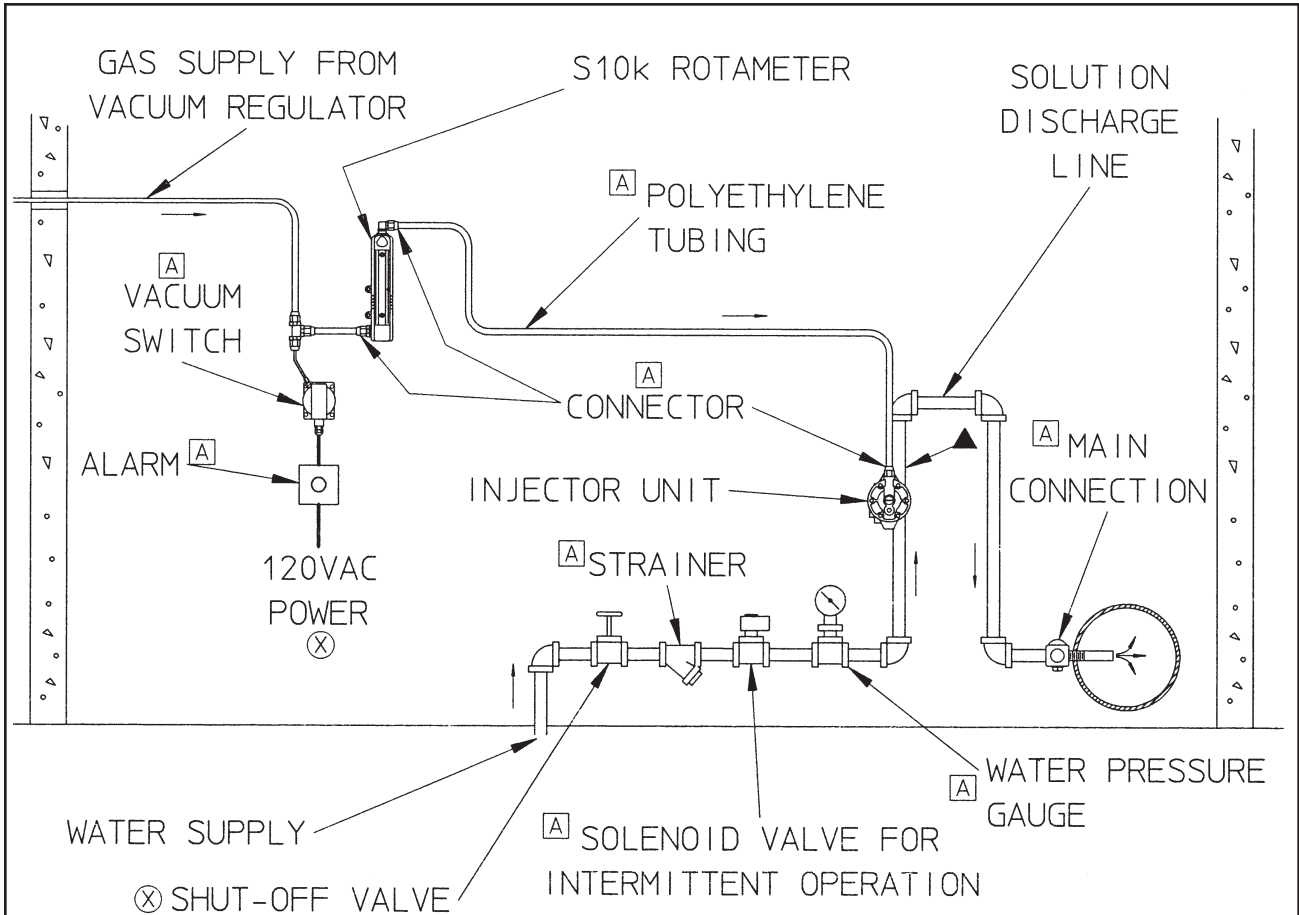

NOTE: [A] ACCESSORY ITEM FURNISHED ONLY IF SPECIFICALLY LISTED ON QUOTATION.

[X] NOT FURNISHED BY EVOQUA WATER TECHNOLOGIES.

▲ SOLUTION HOSE MAY BE CONNECTED DIRECTLY TO THE INJECTOR TAILWAY. IF RIGID PVC PIPE IS USED, A PIECE OF STRAIGHT PIPE AT LEAST EIGHT INCHES LONG SHOULD BE COUPLED TO THE END OF THE INJECTOR TAILWAY BEFORE ANY ELBOWS, TEES OR SIMILAR FLOW RESTRICTIONS ARE USED. THIS IS TO PREVENT ANY FLOW DISTURBANCES THAT COULD AFFECT THE HYDRAULIC PERFORMANCE OF TAILWAY CONNECTIONS.

S10K GAS FEEDER (MANUAL) - TYPICAL INSTALLATION

25.200.110.020

ISSUE 2 6-14

S10K V-NOTCH CHLORINATOR

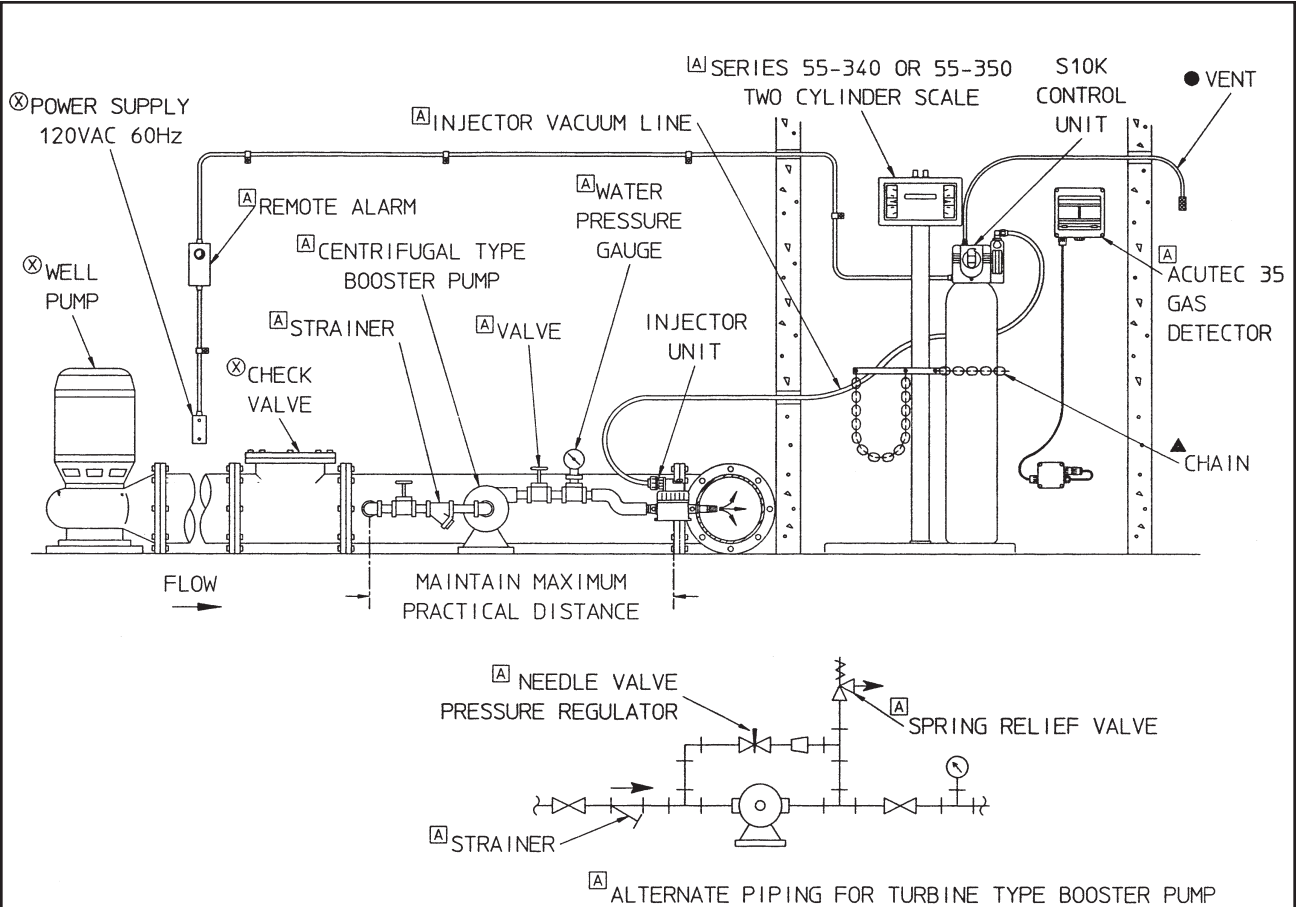

WARNING: ▲ TO AVOID POSSIBLE SEVERE PERSONAL INJURY OR EQUIPMENT DAMAGE, GAS CYLINDERS MUST BE SECURED IN SUCH A MANNER (e.g., CHAIN) AS TO PREVENT THEIR BEING KNOCKED OVER.

● THE VENT LINE MUST TERMINATE IN AN AREA WHERE GAS FUMES CANNOT CAUSE DAMAGE OR INJURY TO PERSONNEL. DO NOT TERMINATE THE VENT LINE AT LOCATION ROUTINELY USED BY PERSONNEL SUCH AS WORK AREAS OR PATHWAYS, NOR NEAR WINDOW OR VENTILATION SYSTEM INTAKES.

NOTE: [A] ACCESSORY ITEM FURNISHED ONLY IF SPECIFICALLY LISTED IN QUOTATION.

⊗ NOT FURNISHED BY EVOQUA WATER TECHNOLOGIES.

VENT DATA: RUN VENT TUBING TO A TREATMENT SYSTEM OR OUTSIDE ATMOSPHERE ON A CONTINUOUS DOWN GRADIENT WITHOUT TRAPS OR ELBOWS AND WITH OUTER END POINTED DOWN. ATTACH SCREEN.

DEWATERING DATA: IF POINT OF APPLICATION CANNOT BE LOCATED BETWEEN VALVES, THE USE OF A CORPORATION COCK TYPE MAIN CONNECTION IS RECOMMENDED TO PERMIT SERVICING THE INJECTOR.

S10K GAS FEEDER - TYPICAL INSTALLATION

25.200.110.030

ISSUE 2 6-14

S10K V-NOTCH CHLORINATOR

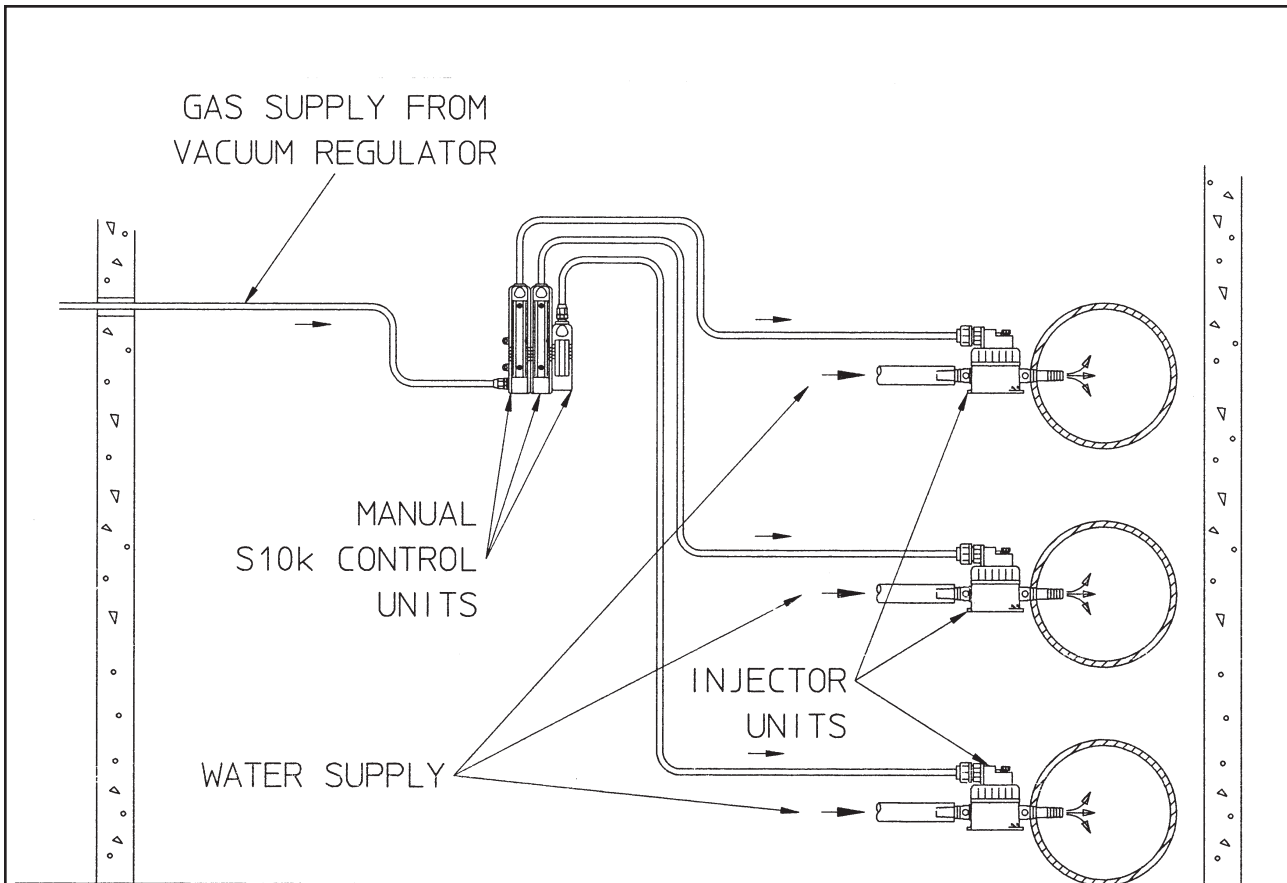

DEWATERING DATA: IF POINT OF APPLICATION CANNOT BE LOCATED BETWEEN VALVES, THE USE OF A CORPORATION COCK TYPE MAIN CONNECTION IS RECOMMENDED TO PERMIT SERVICING THE INJECTOR.

S10K GAS FEEDER (MANUAL) - TYPICAL INSTALLATION
Independent Feed Rate Control to Multiple Points of Application

25.200.110.040

ISSUE 0 10-95

S10K V-NOTCH CHLORINATOR

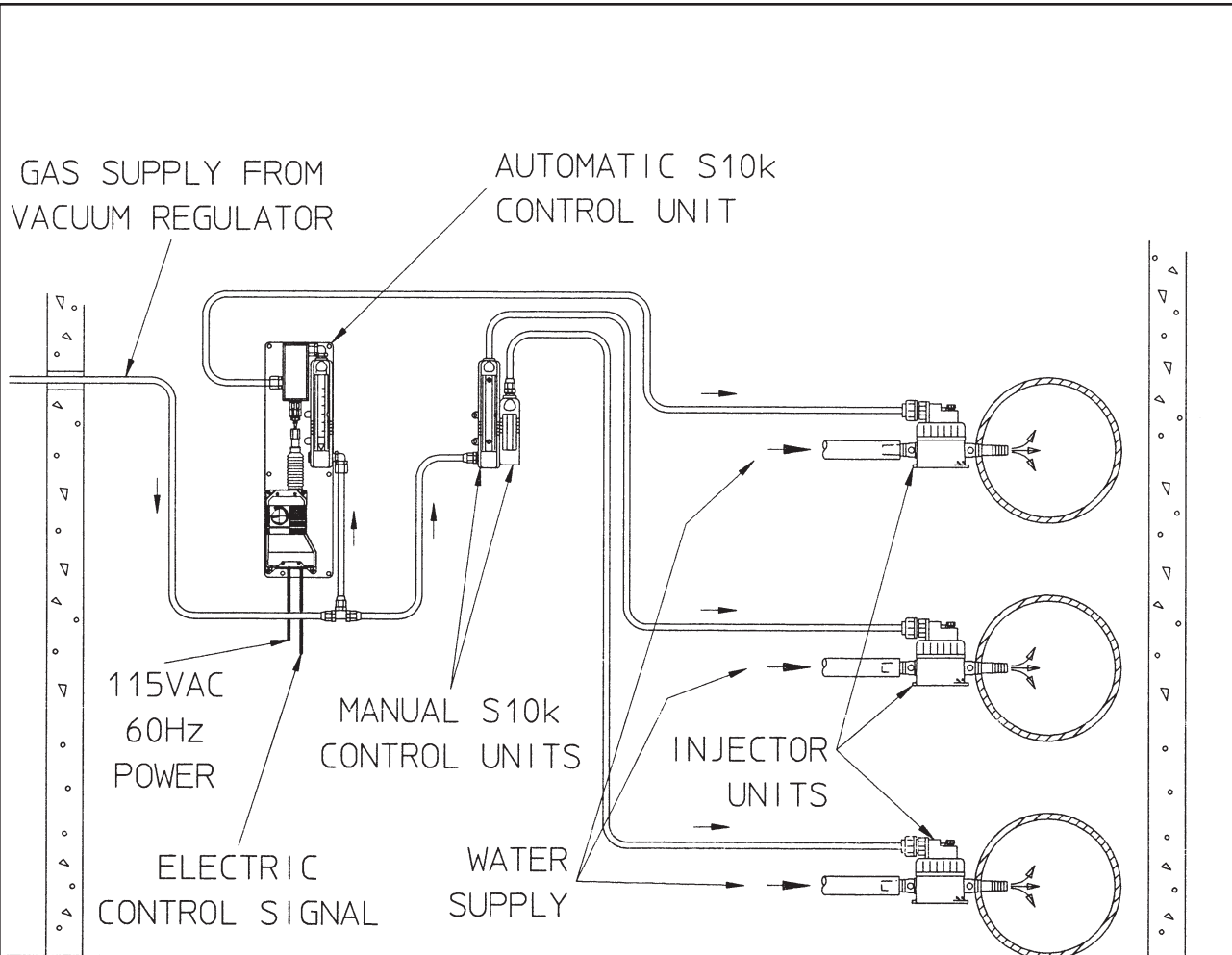

NOTE: IF POINT OF APPLICATION CANNOT BE LOCATED BETWEEN VALVES, THE USE OF A CORPORATION COCK TYPE MAIN CONNECTION IS RECOMMENDED TO PERMIT SERVICING THE INJECTOR.

S10K GAS FEEDER (AUTOMATIC) - TYPICAL INSTALLATION
Independent Feed Rate Control to Multiple Points of Application

25.200.110.050

ISSUE 0 10-95

S10K V-NOTCH CHLORINATOR

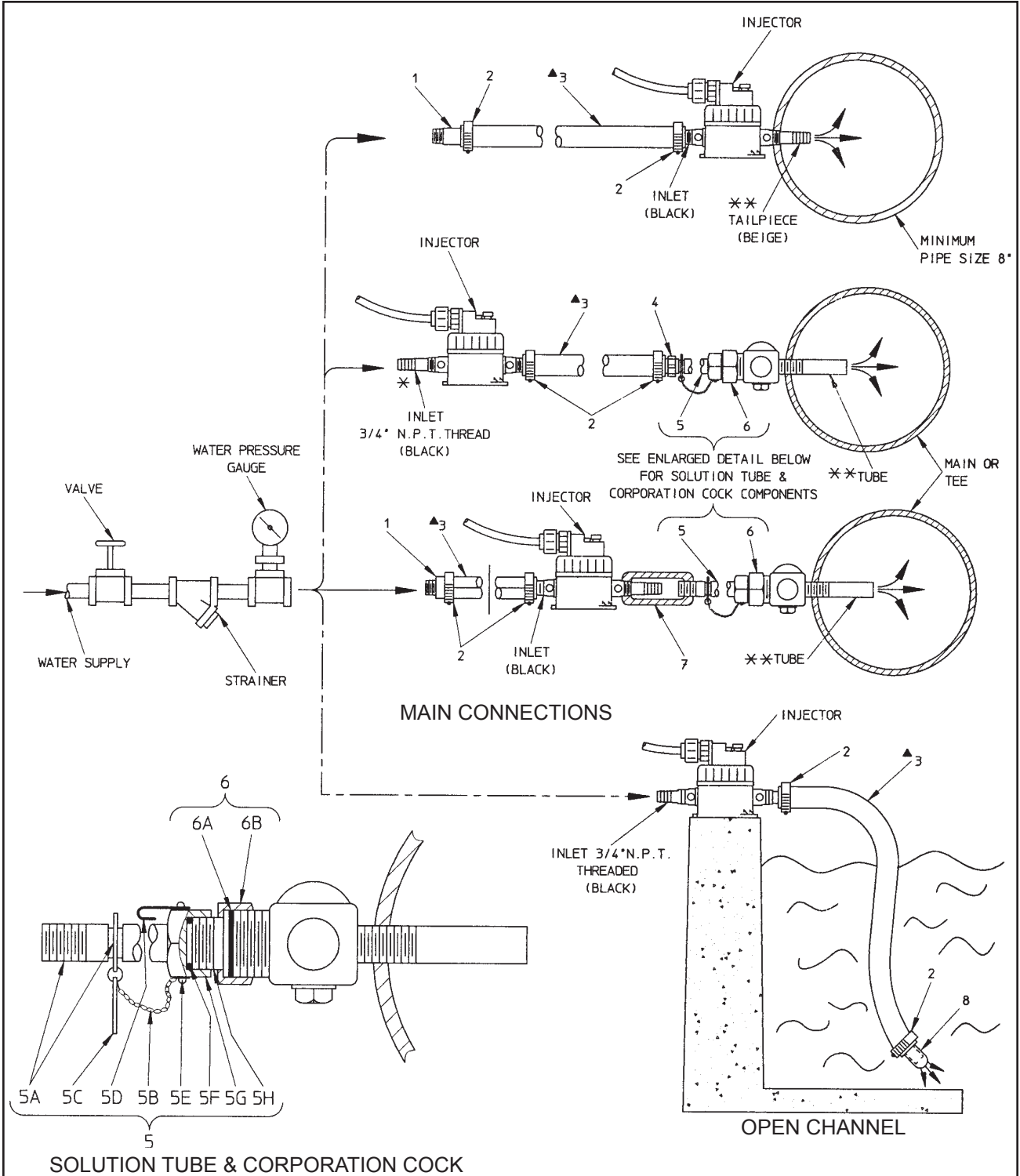

NOTE: FOR PARTS LIST SEE DWG. 25.200.110.060B.

CONNECTIONS TO POINTS OF APPLICATION - TYPICAL INSTALLATION

3/4" Fixed Throat Injector

25.200.110.060A

ISSUE 0 10-95

S10K V-NOTCH CHLORINATOR

REF. NO.	PART NO.	DESCRIPTION
1	PXA3353	ADAPTER, 1/2" MALE NPT x 3/4" FLEXIBLE PLASTIC PIPE (CADMIUM PLATED BRASS)
2	U10120	HOSE CLAMP
▲ 3	RP 684105	3/4" FLEXIBLE PLASTIC PIPE
4	P40435	ADAPTER, 1/2" FEM. NPT x 3/4" FLEXIBLE PLASTIC PIPE
5	U26131	1/2" SOLUTION TUBE
6	U638	CORPORATION COCK WITH 1" MUELLER THD.
	OR	
	U617	CORPORATION COCK WITH 1" MALE THD.
7	P45956	ADAPTER, 1/2" x 3/4" FEM. NPT
8	P16260	3/4" SPRAY NOZZLE

REPLACEMENT PARTS

KEY NO. 5: 1/2" PLASTIC SOLUTION TUBE

5A	U26130	1/2" PLASTIC SOLUTION TUBE
5B	P40384	CHAIN (12" LONG)
5C	P4373	CAUTION TAG
5D	P40432	SAFETY LOCK
5E	P27833	2 MACH. SCREW (TRUSS HD. SS) #10-24 x 3/8" LG.
5F	P7468	O-RING
5G	P37035	PACKING NUT
5H	P37036	GLAND

KEY NO. 6: CORPORATION COCK

6A	P2636	LEATHER GASKET
6B	P2635	GLAND NUT

CAUTION: ** FOR PROPER DISPERSAL OF SOLUTION, THE END OF THE TAILWAY (BEIGE) OR TUBE MUST EXTEND INTO MAIN, BUT NOT MORE THAN 1/3 THE DIAMETER OF THE MAIN.

▲ INJECTOR CONNECTION ABOVE 75 PSI MUST BE RIGID PIPE.

NOTE: * CUT OFF HOSE ADAPTER PORTION OF BLACK NOZZLE. DO NOT CUT OFF TAILWAY (BEIGE).

WHEN ORDERING MATERIAL, ALWAYS SPECIFY MODEL AND SERIAL NUMBER OF APPARATUS.

CONNECTIONS TO POINTS OF APPLICATION - TYPICAL INSTALLATION
3/4" Fixed Throat Injector

25.200.110.060B

ISSUE 0 10-95

S10K V-NOTCH CHLORINATOR

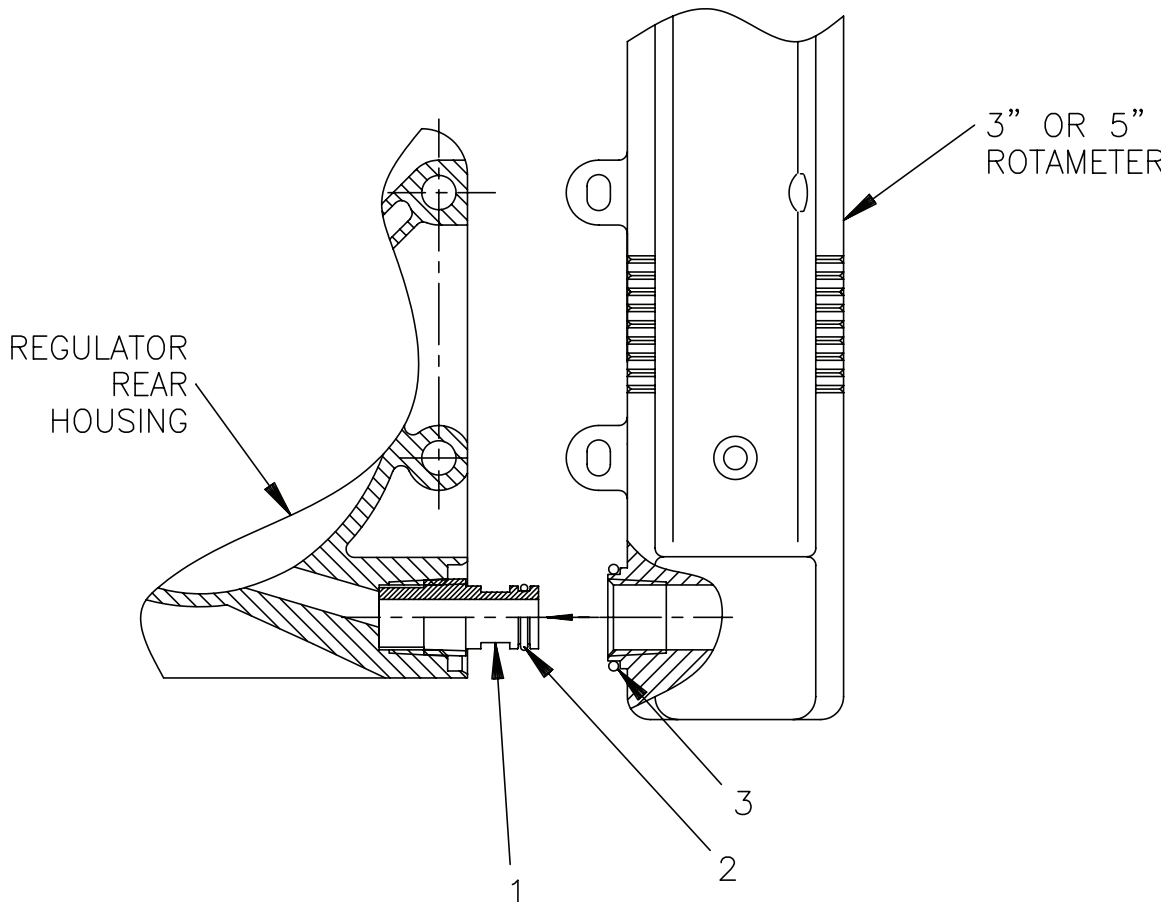

KEY NO.	PART NO.	QTY.	DESCRIPTION
1	AAA3491	1	CONNECTOR
2	PXH26345	1	O-RING (SMALL)
3	P44123	1	O-RING (LARGE)

WHEN ORDERING MATERIAL, ALWAYS SPECIFY MODEL AND SERIAL NUMBER OF APPARATUS.

S10K V-NOTCH GAS FEEDER COMPONENT INTERCONNECTION
- TYPICAL INSTALLATION

25.200.110.080

ISSUE 0 3-00

S10K V-NOTCH CHLORINATOR

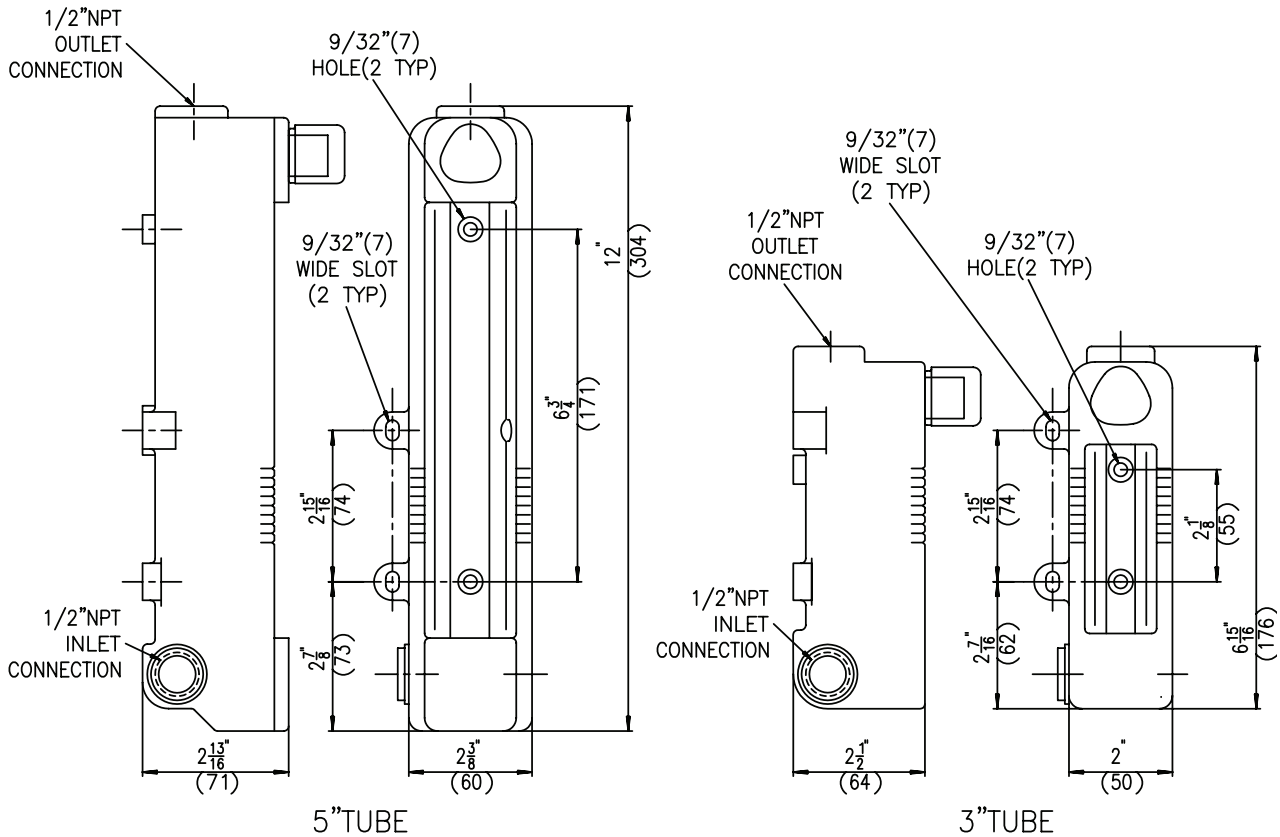

NOTE: () DIMENSIONS ARE IN MILLIMETERS.

S10K V-NOTCH GAS FEEDER ROTAMETER HOUSINGS - DIMENSIONS

25.200.100.050

ISSUE 0 3-00

S10K V-NOTCH CHLORINATOR

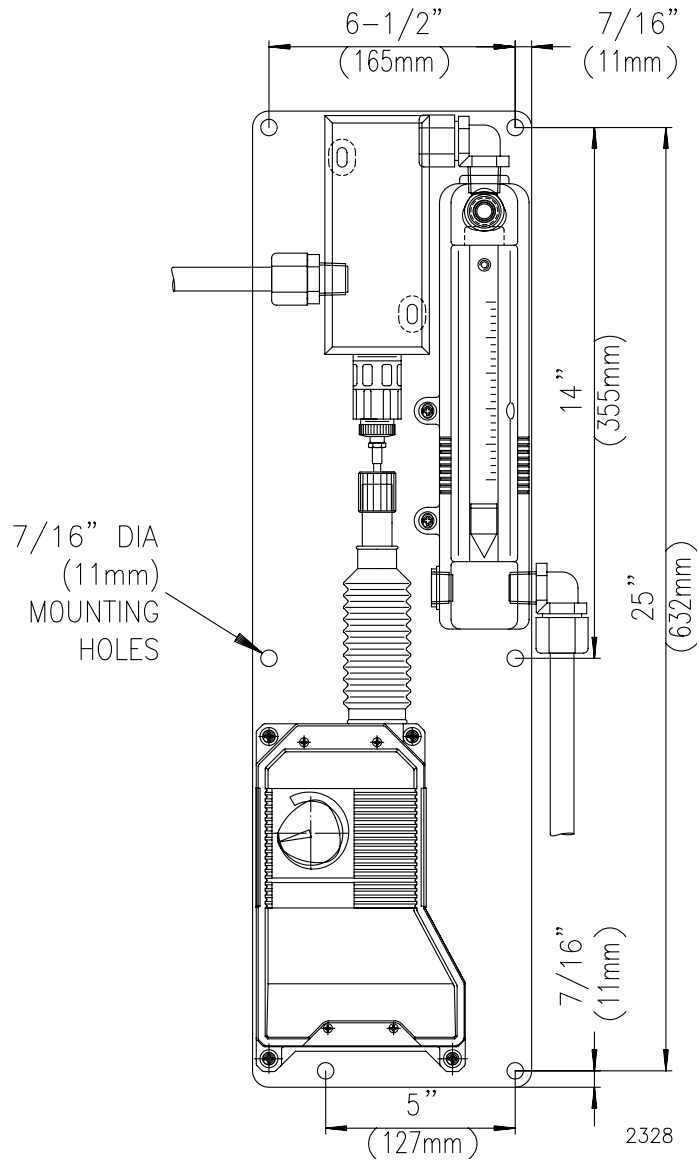

NOTE: () DIMENSIONS ARE IN MILLIMETERS.

S10K V-NOTCH GAS FEEDER AUTOMATIC CONTROL PANEL - DIMENSIONS

25.200.100.060

ISSUE 0 3-00

S10K V-NOTCH CHLORINATOR

TEMPERATURE AND PRESSURE:

PVC PIPE IS NOT RECOMMENDED FOR TEMPERATURES OVER 130°F OR BELOW 0°F, NOR FOR LINES THAT MAY BE EXPOSED TO PHYSICAL ABUSE (SEE MANUFACTURER'S RECOMMENDATIONS). ONE HUNDRED FEET OF PIPE WILL EXPAND OR CONTRACT APPROXIMATELY 0.7 INCHES FOR EVERY 10°F TEMPERATURE CHANGE. MANUFACTURER'S RECOMMENDED MAXIMUM WORKING PRESSURES SHOULD NOT BE EXCEEDED.

SUPPORT AND PROTECTION:

IT IS PREFERABLE TO SUPPORT HORIZONTAL OVERHEAD LINES WITH A CHANNEL OR ANGLE IRON PARALLEL TO THE PIPE. IF STRAP HANGERS ARE USED, SPACE THEM AT 2- TO 4-FOOT INTERVALS, AS RECOMMENDED BY THE PIPE MANUFACTURER. PIPE SHOULD NOT REST DIRECTLY ON RODS OR WIRES. PIPE MAY BE LAID UNDERGROUND WITH NO SPECIAL PRECAUTIONS OTHER THAN THOSE USED FOR IRON PIPE.

THREADING:

SCHEDULE 80 PVC PIPE CAN BE CUT AND THREADED WITH STANDARD PIPE TOOLS, EITHER HAND OR POWER DRIVEN. STANDARD DIES COMMONLY USED FOR METAL PIPE WILL PRODUCE SATISFACTORY THREADS, THOUGH A 5° NEGATIVE RAKE ANGLE IS PREFERRED. KEEP DIES CLEAN AND SHARP AT ALL TIMES. DIES THAT HAVE BEEN USED EXTENSIVELY FOR STEEL PIPE MAY NOT PRODUCE GOOD THREADS UNLESS RESHARPENED. USE NORMAL CUTTING SPEEDS; NO LUBRICANT OR CUTTING OIL IS REQUIRED. A TAPERED PLUG (AVAILABLE FROM THE MANUFACTURER, IF DESIRED) TAPPED FIRMLY INTO THE END OF THE PIPE PREVENTS DISTORTION OF THE PIPE AND DIGGING-IN BY THE DIE, AS WELL AS CORRECTS ANY SLIGHT OUT-OF-ROUND THAT MAY EXIST. TAKE CARE TO CENTER THE DIE ON THE PIPE AND ALIGN THE THREAD TO PREVENT REDUCING THE WALL EXCESSIVELY ON ONE SIDE. SCHEDULE 40 PVC CANNOT BE THREADED.

THREADED JOINTS:

THREADED JOINTS IN PVC PIPE REQUIRE MORE CARE THAN THOSE IN SIMILAR SIZE METAL PIPE. IF A NON-LUBRICATING THREAD COMPOUND IS USED, THE JOINT MAY FEEL TIGHT WHEN ONLY 2 OR 3 THREADS ARE ENGAGED. IF TEFLON TAPE OR SIMILAR LUBRICATING THREAD COMPOUND IS USED, THE JOINT MAY NOT FEEL TIGHT AT ALL, AND OVERTIGHTENING—RESULTING IN CRACKED FITTINGS OR STRIPPED THREADS—CAN EASILY OCCUR. CARE MUST BE TAKEN TO ENGAGE THE JOINED PARTS TO A NORMAL ENGAGEMENT OF 5 TO 7 TURNS AND NO MORE. STRAP WRENCHES ARE PREFERRED FOR ASSEMBLY, AS THE SHARP EDGES ON PIPE WRENCHES MAY SCORE AND WEAKEN THE PIPE.

FLANGED JOINTS:

FOR FLANGED JOINTS, USE A FULL-FACED RUBBER GASKET AND FLAT WASHERS UNDER BOLTS AND NUTS. TIGHTEN OPPOSITE FLANGE BOLTS TO COMPRESS THE GASKET TO A SLIGHT DEGREE, BUT DO NOT DISTORT THE FLANGE.

SOLVENT WELD OR CEMENT JOINTS:

ALWAYS USE CEMENT RECOMMENDED BY THE MANUFACTURER. ADD THINNER IF CEMENT THICKENS FROM EXPOSURE TO THE AIR.

1. CUT PIPE WITH ORDINARY HAND OR POWER SAW. MAKE A SQUARE CUT AND REMOVE BURRS.
2. CLEAN AND DRY OUTSIDE OF PIPE AND INSIDE OF FITTING.
3. APPLY A THIN COAT OF CEMENT TO INSIDE OF FITTING AND OUTSIDE OF PIPE. USE A NATURAL BRISTLE PAINT BRUSH. CEMENT TO BE WITHIN 1/4" BUT NOT CLOSER THAN 1/8" FROM END OF PIPE TO PREVENT INTERNAL BEAD FROM FORMING.
4. WHILE THE CEMENT IS STILL WET, STAB THE PIPE INTO THE FITTING AND GIVE 1/8 TURN.
5. AVOID ROUGH HANDLING FOR ONE HOUR. DEPENDING ON ATMOSPHERIC CONDITIONS, APPROXIMATELY 50% STRENGTH WILL BE ATTAINED IN 2 HOURS AND FULL STRENGTH IN 48 HOURS.

PIPE SIZE	1/2"	3/4"	1"	1-1/4"	1-1/2"	2"	3"	4"
JOINTS PER PINT OF CEMENT	50	50	35	35	25	25	16	12

CEMENT AVAILABLE FROM EVOQUA WATER TECHNOLOGIES IN PINT CANS (U24647). ALSO AVAILABLE COMMERCIALY IN PINT, QUART AND GALLON CANS.

**PVC PIPE - INSTALLATION
Fabrication and Installation**

50.830.110.011
ISSUE 14 6-14

SECTION 3

S10K V-NOTCH CHLORINATOR

SECTION 3 - OPERATION

List Of Contents

	PARA./DWG. NO.
Preparation for Initial Operation	3.1
Operation	3.2
Starting	3.2.1
Stopping	3.2.2
Intermittent Start-Stop	3.2.3
Electric Positioner	3.2.4
Electronic Controller	3.2.5
Multiple Points of Application	3.3
Changing Gas Supply Cylinders.....	3.4
Theory of Operation	3.5
Illustrations	
Flow Diagram - S10K Gas Feeder - Manual	
Arrangement	25.200.180.010

3.1 Preparation for Initial Operation



WARNING: HAZARDOUS GAS IS PRESENT IN THIS EQUIPMENT DURING NORMAL OPERATION. TO AVOID POSSIBLE SEVERE PERSONAL INJURY OR DAMAGE TO THE EQUIPMENT, READ THIS INSTRUCTION BOOK AND THE APPROPRIATE GAS MANUAL BEFORE CONNECTING THIS EQUIPMENT TO A SUPPLY OF GAS. OPERATION AND MAINTENANCE OF THIS EQUIPMENT MUST BE RESTRICTED TO TRAINED, QUALIFIED PERSONNEL WHO ARE COMPLETELY FAMILIAR WITH THESE INSTRUCTIONS.

When all connections specified under installation have been made, check the gas feeder as follows:

- a. If the point of application is in a main through a corporation cock or valve, the cock or valve must be open. Push the solution tube, if furnished, in until the end extends into the main, approximately 1/3 to 1/2 the diameter of the main. In the case of large mains, the tube may be pushed in as far as it will go.
- b. With the gas supply container valve(s) off, and the vacuum regulator(s) in the standby or operating position, turn the injector shut-off valve on and any other valves in the injector water supply line on. Proper injector vacuum can be observed on the vacuum regulator(s) when the gray knob drops down and the color indicator on the front of the vacuum regulator turns red. If sufficient vacuum cannot be obtained consult Section 4 for information on service and troubleshooting.
- c. If proper injector operation is indicated, test the gas supply line for leaks. Start at the source of gas supply and open valves in sequence. Test each valve and connection for leaks as the valve is opened by holding the moistened dauber from the bottle of ammonia furnished near the point to be tested. A gas leak will produce a white vapor because of the reaction between chlorine and ammonia. If a leak is detected, shut off the gas supply immediately and allow the gas to be exhausted from the system. (See details under paragraph 3.2.2, Stopping - For Extended Periods.) Correct the leak before further testing or operation is attempted.

3.2 Operation

NOTE: The following procedures assume all preparatory steps and leak tests have been completed.

3.2.1 Starting

- a. Turn vacuum regulator(s) to the OPERATING position. Turn on the water supply to the injector and open the V-notch plug part-way. If there are two vacuum regulators (automatic switchover system) turn on only the one on the gas cylinder from which it is desired to withdraw first. This will

create a vacuum which causes the grey knob to drop down and the color indicator on the front of the vacuum regulator to turn red when the gas is shut off.

- b. Turn on the gas supply at the supply container valve. Put the knob in the operating position.



WARNING: TO AVOID POSSIBLE SEVERE PERSONAL INJURY OR EQUIPMENT DAMAGE, DO NOT OPEN THE GAS SUPPLY CONTAINER VALVE MORE THAN ONE TURN APPROXIMATELY. THIS WILL PERMIT MAXIMUM DISCHARGE AND ALSO CAN BE TURNED OFF QUICKLY IN THE EVENT OF A GAS LEAK.

- c. If there are two vacuum regulators, open the gas cylinder valve on the stand-by cylinder approximately one turn and push the knob of the stand-by vacuum regulator to STANDBY.

3.2.2 Stopping

- For Short Periods - Turn off the injector water supply.
- For Extended Periods - Turn off the gas supply at the gas supply container valve. Wait until the gray knob drops down and the color indicator on the front of the vacuum regulator turns red, and the rotameter float rests on the bottom stop, and then turn off the injector.

3.2.3 Intermittent Start-Stop Operation

The gas feeder may be operated automatically in the start-stop mode by controlling the injector water supply with an electrically operated solenoid valve in the injector water supply line and connecting it so the valve is open when the booster pump is running and closed when the booster pump is shut down.

3.2.4 Electric Positioner

Instructions for the electric positioner are provided in a separate book.

3.2.5 Electronic Controller

Instructions for the electronic controller are provided in a separate book.

3.3 Multiple Points of Application

If there are one or more control units in the system, these may be started and stopped at will, independent of each other as long as the gas supply is turned on. The operation of the injector associated with each control unit determines whether or not it will feed gas.

3.4 Changing Gas Supply Cylinders

Refer to the separate instruction book provided with the vacuum regulator for detailed instructions and precautions.

3.5 Theory of Operation

The Evoqua Water Technologies S10K V-Notch Gas Feeder and its accessories are designed to control and indicate the rate of flow of gas within the range of the machine, to mix the gas with water, and to deliver the resultant solution to the point of application.

In the gas feeder, the function of the injector is to produce a vacuum to draw gas from the control unit and to mix this gas with the water flowing through a fixed throat injector. Check valves are built into the fixed throat injectors to prevent a back flow of water into the gas feeder if the injector water supply is shut off with pressure on the injector discharge, or if the injector discharge line becomes restricted. Proper operation of the injector is dependent on the inlet pressure being sufficiently higher than the discharge pressure. Thus the flow through the V-notch orifice is entirely a function of the size of the orifice as determined by the position of the V-notch plug as positioned manually or by an electric positioner operating in response to an external signal. Manual override at the positioner is provided.

From the vacuum regulator, gas under a controlled vacuum passes to the rotameter (feed rate indicator) in the control unit, causing the float to indicate the rate of flow on an easily read scale. As stated above, the rate of flow is controlled by the position of the V-notch variable orifice across which a differential at less than atmospheric pressure is maintained, to achieve sonic gas flow. From the control unit, gas passes to the injector where it is mixed with water and the resultant solution is discharged to the point of application.

S10K V-NOTCH CHLORINATOR

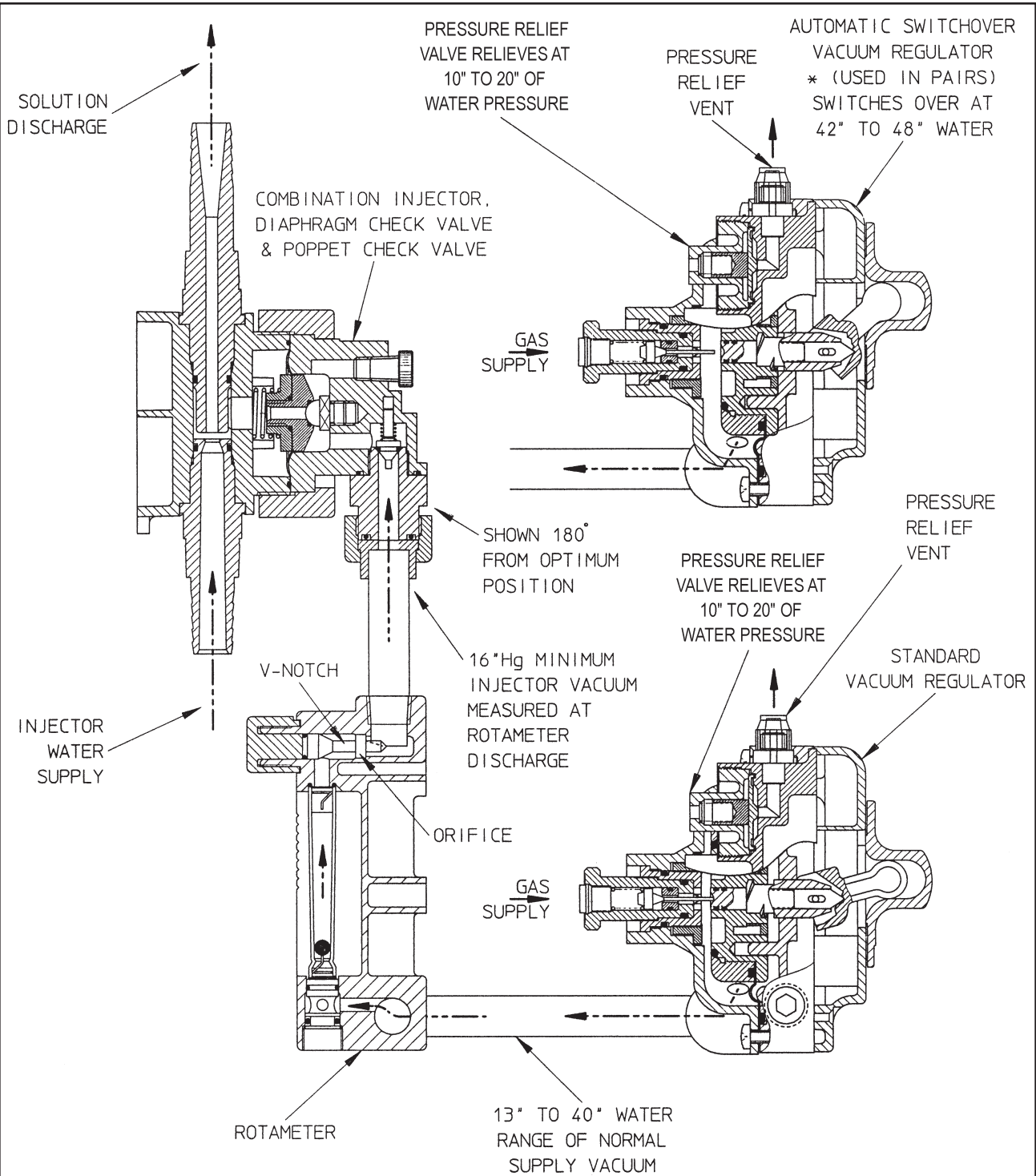

NOTE: * SHOWN IN STANDBY POSITION.

S10K GAS FEEDER - FLOW DIAGRAM
Manual Arrangement

25.200.180.010

ISSUE 0 10-95



S10K V-NOTCH CHLORINATOR

SECTION 4

S10K V-NOTCH CHLORINATOR

SECTION 4 - SERVICE

List Of Contents

	PARA./DWG. NO.
General	4.1
Checking for Chlorine Leaks	4.1.1
Water Leaks.....	4.1.2
Inspection	4.2
Plastic Parts	4.3
Gasket/O-Rings.....	4.4
Injector	4.5
Removal of V-Notch Plug.....	4.6
Zero Position of V-Notch Plug for Electric Control	4.7
Preparation for Winter Shut-Down	4.8
Maintenance.....	4.9
Performance Check	4.9.1
Cleaning Vacuum Regulator	4.9.2
Cleaning Rotameter.....	4.9.3
Cleaning V-Notch Plug.....	4.9.4
Cleaning Injector Throat and Tailway	4.9.5
Cleaning 3/4" Fixed Throat Injector (Standard)	4.9.6
Cleaning 3/4" Fixed Throat Injector (Anti-Syphon)	4.9.7
Cleaning 1" Fixed Throat Injector (Standard)	4.9.8
Cleaning 1" Fixed Throat Injector (Anti-Syphon)	4.9.9
Periodic Preventive Maintenance.....	4.10
Testing of Remote Pressure Relief Valve	4.10.1
Troubleshooting.....	4.11
Warning/Caution Summary Page	1 Page
Illustrations	
Service - Zero Position of Plug.....	25.200.150.010



WARNING: HAZARDOUS GAS IS PRESENT IN THIS EQUIPMENT DURING NORMAL OPERATION. TO AVOID POSSIBLE SEVERE PERSONAL INJURY OR DAMAGE TO THE EQUIPMENT, READ THIS INSTRUCTION BOOK AND THE APPROPRIATE GAS MANUAL BEFORE CONNECTING THIS EQUIPMENT TO A SUPPLY OF GAS. OPERATION AND MAINTENANCE OF THIS EQUIPMENT MUST BE RESTRICTED TO TRAINED, QUALIFIED PERSONNEL WHO ARE COMPLETELY FAMILIAR WITH THESE INSTRUCTIONS.

4.1 General



WARNING: EXCEPT WHEN DETECTING LEAKS OR MAKING CALIBRATION ADJUSTMENTS, TO AVOID POSSIBLE SEVERE PERSONAL INJURY OR EQUIPMENT DAMAGE, THE GAS SUPPLY MUST BE SHUT OFF AT THE GAS SUPPLY CONTAINER(S) AND THE GAS IN THE SYSTEM MUST BE COMPLETELY EXHAUSTED BEFORE BREAKING ANY CONNECTIONS OR SERVICING THE EQUIPMENT. TO DO THIS, TURN OFF THE GAS SUPPLY AT THE CONTAINER VALVE, WAIT UNTIL THE GRAY KNOB DROPS DOWN AND THE COLOR INDICATOR ON THE FRONT OF THE VACUUM REGULATOR TURNS RED AND THE ROTAMETER FLOAT RESTS ON THE BOTTOM STOP, AND THEN TURN OFF THE INJECTOR WATER SUPPLY.

General precautions simplify maintenance. These are easy to accomplish and will minimize repairs by providing good operating conditions. Suggested precautions are:

4.1.1 Checking for Chlorine Leaks



WARNING: TO AVOID POSSIBLE SEVERE PERSONAL INJURY OR EQUIPMENT DAMAGE, NO LEAKS SHOULD BE TOLERATED. THEY ALWAYS GET PROGRESSIVELY WORSE AND MUST BE PROMPTLY CORRECTED. IT IS GOOD PRACTICE TO HAVE AN APPROVED GAS MASK AVAILABLE WHEN MAKING LEAK CHECKS.

A bottle of aqueous ammonia with dauber is available for checking leakage of chlorine gas at joints, valves, etc. Hold wet dauber or uncapped bottle close to the joint or suspected leakage area. If leakage exists, a white cloud will form. When a leak is found, immediately shut off gas supply and remove the escaped gas, by ventilation. Continue to operate the injector until the gray knob drops down and the color indicator on the front of the vacuum regulator turns red, and the rotameter float rests on the bottom stop.

Eliminate the leak before proceeding.



WARNING: ESCAPED GAS MUST BE EXHAUSTED TO A TREATMENT SYSTEM OR OUTSIDE ATMOSPHERE. THE EXHAUST SYSTEM MUST TERMINATE IN AN AREA WHERE GAS CANNOT CAUSE INJURY TO PERSONNEL OR PROPERTY DAMAGE. DO NOT TERMINATE THE EXHAUST SYSTEM AT A LOCATION ROUTINELY USED BY PERSONNEL, SUCH AS WORK AREAS OR PATHWAYS NOR NEAR WINDOWS OR VENTILATION SYSTEM INTAKES.

Check connections for leaks once a day. Green or reddish deposits on metal parts indicate leaks. No gas odor should be in evidence around equipment except when a joint is temporarily opened.

NOTE: For leak testing use Evoqua Water Technologies U409 or Commercial 26° Baume' aqua ammonia. (Household ammonia is not strong enough.)



CAUTION: When any connection is broken even for a short time, immediately plug the resultant opening with rubber stopper or equivalent to prevent the entrance of moisture. Moisture must be excluded from any part of the equipment which is normally exposed to dry gas only. While dry gas is non-corrosive, moist gas is extremely corrosive to common metals such as brass or steel.

4.1.2 Water Leaks

NOTE: As a matter of routine maintenance, do not tolerate water leaks. Repair all water leaks as soon as they are discovered.

4.2 Inspection

After the disassembled parts are cleaned and prior to reassembly perform the following:

- a. Check for physical damage to removed parts (chipped, cracked, damaged threads, etc.). Replace damaged parts.
- b. Discard and replace all removed O-rings, seals and gaskets.
- c. Check diaphragms for chafing or cracking. Replace damaged diaphragms.

4.3 Plastic Parts

Whenever threaded plastic parts are assembled, use Teflon tape or Halocarbon grease U27546 on the threads to prevent the parts from freezing together.

In general do not use tools to make up plastic connections. Make this type of connection by hand.

4.4 Gaskets/O-Rings

A supply of gaskets and O-rings must be kept on hand so that all gasketed joints can be maintained in proper condition. Regular replacement of gaskets will minimize operating difficulties and is recommended. The preventive maintenance kit includes a set of gaskets.



WARNING: TO AVOID POSSIBLE SEVERE PERSONAL INJURY OR EQUIPMENT DAMAGE, NEVER REUSE GASKETS. ALWAYS REPLACE WITH A NEW GASKET OF THE PROPER SIZE AND MATERIAL AS IDENTIFIED ON THE EQUIPMENT PARTS DRAWING.

4.5 Injector

Good injector performance is necessary for proper gas feeder performance. The gas feeder has been tested to ensure that it will deliver the required flow of gas when operated under the hydraulic conditions specified on the Evoqua Water Technologies shipping order. If difficulty is experienced in obtaining the specified capacity at time of installation, check the injector operating water pressure and backpressure to see that they conform to the values specified on the order. If operating difficulties are encountered after the gas feeder has been in operation, study the injector parts drawing to become familiar with the assembly of the injector. Check the following list for some of the factors which may produce faulty injector action.

- Dirty Water Strainer

A strainer is required in the water line ahead of the injector to avoid plugging of the injector throat ports by foreign material. If sufficient material is allowed to build up on the strainer surface, the resultant pressure drop across the strainer reduces the injector operating water pressure. If the pressure drop is excessive, the injector will not be able to induct the required gas flow. Regular periodic inspection and cleaning of the strainer will minimize the possibility.

- Installation of Throat and Tailway

The throat and tailway must be assembled as shown on the parts drawing. If faulty injector action is suspected, inspect the gaskets and replace them if necessary.

- Plugging of the Injector Ports

The injector will not operate satisfactorily unless all the ports are clear. This point is easily checked by visual inspection after the throat has been removed. If the injector water supply contains appreciable amounts of manganese or iron, these may deposit in the throat or tailway over a long period and eventually interfere with the injector action. Such deposits are readily recognizable by their black or reddish color. They may be removed by immersing the throats in dilute (10%) hydrochloric acid (known commercially as muriatic acid).



WARNING: TO AVOID POSSIBLE SEVERE PERSONAL INJURY OR EQUIPMENT DAMAGE, WHEN WORKING WITH HYDROCHLORIC ACID OBSERVE ALL SAFETY PRECAUTIONS RECOMMENDED BY THE ACID MANUFACTURER/SUPPLIER.

4.6 Removal of V-Notch Plug (See Dwg. 25.200.000.010)

- a. Shut down gas feeder and exhaust all gas as directed under Section 3 - Operation.
- b. Put electric actuator in manual position as described in electric actuator book. Rotate knob to lower actuator shaft down as far as possible.
- c. Disconnect clamp nut (9).
- d. Unscrew extension chamber (7) from V-notch chamber (24).
- e. Push plug stem until orifice (23) is dislodged from extension chamber (7).
- f. Unscrew V-notch plug (25) from stem (20).
- g. Reassemble in reverse order.

4.7 Zero Position of V-Notch Plug for Electric Control (See Dwg. 25.200.150.010)

When the electronic controller is receiving a zero flow signal, adjust lock nut and coupling screw until the V-notch is at its zero position, then tighten.

To determine this position, proceed as directed in preceding Steps a through d. With the V-notch plug and plug stem in the extension chamber and the orifice seated, move the plug stem in or out as required until the scratch line on the bottom of the plug is even with the bottom of the orifice as viewed through the holes in the extension chamber. Make a pencil line around the plug stem even with the bottom of the seal clamping screw. This pencil line may then be used as a zero reference when the parts are reassembled in the control unit and the linkage is adjusted to match the zero of the electric actuator.

4.8 Preparation for Winter Shut-Down

If the gas feeder is to be shut down for an extended period during freezing weather, the following procedure must be followed.



WARNING: TO AVOID POSSIBLE SEVERE PERSONAL INJURY OR EQUIPMENT DAMAGE, SHUT OFF GAS SUPPLY AT THE GAS SUPPLY CONTAINER VALVE. OPERATE THE INJECTOR WITH THE GAS SUPPLY TURNED OFF UNTIL THE GRAY KNOB DROPS DOWN AND THE COLOR INDICATOR ON THE FRONT OF THE VACUUM REGULATOR TURNS RED, AND THE ROTAMETER FLOAT SETTLES ON BOTTOM STOP.

- a. Shut off the water supply and drain the line to the injector.
- b. Drain the solution discharge line, and prevent any water flow into discharge line.

- c. Drain any water in the injector.

NOTE: If the equipment is to be removed for storage, seal all fittings and all gas lines with rubber stoppers to prevent the entrance of atmospheric moisture during the storage period. If a pump is being used, follow the pump manufacturer instructions for extended shut-down.

4.9 Maintenance

Maintenance of the S10K Gas Feeder system consists of three periodically performed operations:

- Periodic Performance Checks to detect the onset of any deteriorating conditions before their progress leads to serious malfunction.
- Periodic Cleaning to remove contaminants and deposits brought to the vacuum regulator(s) and control unit(s) by the gas flow and to the injector(s) by the water flow.
- Periodic Preventive Maintenance to disassemble, inspect, clean and accomplish recommended parts replacement. Kits of replacement parts required for this periodic maintenance are available and are listed in Section 6 - Preventive Maintenance Kits.

PROTECT YOUR EQUIPMENT INVESTMENT
MINIMIZE DOWNTIME
REORDER A PREVENTIVE MAINTENANCE KIT NOW
KEEP ONE ON HAND

NOTE: If the gas feeder is used seasonally (long-term shut-down) the preventive maintenance should be performed prior to startup.

4.9.1 Performance Check

To assure that all elements of your system are functioning normally, check the following at approximately three-month intervals. These checks are easily performed and require no tools.

- a. With the gas turned on at the supply cylinder valve and at the vacuum regulator and with the injector operating, vary the feed of the control unit through its full range. The gas should feed steadily and hold any rate set from the maximum of the rotameter down to 1/20th of maximum. The rotameter float should not stick or behave erratically at any point.
- b. With the injector still operating, turn off the gas at the supply cylinder valve. In a few moments the red indicator will appear on the front cover of the vacuum regulator. After initially rising, the rotameter float sinks lower and lower in the tube until finally it is resting on the bottom stop. Decrease the

S10K V-NOTCH CHLORINATOR

feed rate, if necessary, to prevent the float from bouncing violently and damaging the glass tube. Failure of the float to settle down, indicates an air leak somewhere upstream of the rotameter.

- c. When the indicator is red and the rotameter float has settled on the bottom stop turn off the injector operating water. A rapid decrease in vacuum indicates an air leak somewhere in the system.
- d. If the system is equipped with automatic switchover vacuum regulators, operate the gas feeder with only one unit turned on. Put the second unit in standby and then close the gas supply cylinder valve for the first unit. The vacuum level should momentarily increase and then decrease and the knob of the second unit should be observed to snap down about 3/8 inch as it assumes the feeding function. Repeat the procedure reversing the switchover unit selection to check that the opposite one will also pull in automatically. If either unit does not switch on automatically it is an indication that the detent mechanism needs servicing.
- e. Close the gas supply cylinder valve(s). Shut off the injector and let normal backpressure remain. Remove the tubing from the connection at the injector. No water should drip from the end of the disconnected tubing. Leave the tubing disconnected for approximately 10 minutes. Note if any water appears at the outer end of the connection fitting on the injector. Appearance of water is an indication that the injector backchecks should be serviced.
- f. With the injector shut off and the gas supply cylinder valve closed, turn the vacuum regulator off. Remove the tubing from its connection on the unit. Crack the gas cylinder valve open about 1/8th of a turn and using an ammonia dauber near the outlet of the unit, verify that the unit shuts off tightly (no white vapors). Close the gas cylinder valve. A slight trace of vapor at the moment of disconnection may be ignored but any continuing vapor formation is an indication of gas passing the valve seat. If this is observed, service the stem and seat parts.

Perform at intervals as tabulated below:

MAINTENANCE ITEM	WHEN TO PERFORM
Stems, Spring, and Passageways in Vacuum Regulator	Refer to separate instruction book.
Rotameter	When deposits are seen inside the glass tube or the float sticks in one place.
V-Notch Plug	At same time as rotameter.
Injector Throat and Tailway	Every six months.

NOTE: The actual frequency of cleaning will depend on calendar time, the feed rate and amount of gas fed, the care exercised in cylinder changing, the source of gas, and on the quality of the operating water. The above maintenance schedule provides recommended cleaning intervals. However, your own operating experience is the best guide to preventive maintenance and may result in significant variations from the recommended schedule.

4.9.2 Cleaning Vacuum Regulator

Cleaning instructions for the vacuum regulators are provided in a separate book which is shipped with the units.

4.9.3 Cleaning Rotameter

If a milky white, powdery white, green slimy or brown oily deposit is visible inside the rotameter tube or if the float has particles clinging to it or tends to stick to the tube wall at lower feeds, clean the rotameter. Do not drop the glass tube or float. Have a clean cup (such as a coffee cup or a small beaker) and a pair of tweezers at hand before starting. Proceed as follows:

- a. Turn the knob on the vacuum regulator(s) to OFF. Turn injector on and open rotameter rate valve. After the gray knob drops down and the color indicator on the front of the vacuum regulator turns red, and the rotameter float settles on the bottom stop, turn off the injector operating water.
- b. Insert the curved edge of an open wrench or similar tool into the slot in the rotameter jackscrew, loosen the jackscrew (CCW) and remove it. Carefully remove the rotameter tube from its housing. Take care not to lose the end stops, the float and the gaskets.
- c. Place the end stops and float into the cup mentioned above.
- d. Many gas contaminants are soluble in water. Hold the tube end under running warm (110-125°F) water so that the water enters the tube at one end and exits at the other to flush out deposits. Soak the tube in a container of warm water for about 30 seconds. Then hold the tube (half full with water) with palms capping the ends and shake vigorously endwise for a few seconds. Discharge the water and repeat until clean. A common pipe cleaner may be used to scrub the interior. A detergent will promote cleaning action.



WARNING: DO NOT USE HYDROCARBONS OR ALCOHOLS BECAUSE RESIDUAL SOLVENT MAY REACT WITH GAS. SOLVENTS CAN PRODUCE SERIOUS PHYSIOLOGICAL EFFECTS UNLESS USED IN STRICTEST COMPLIANCE WITH THE SOLVENT MANUFACTURER'S SAFETY RECOMMENDATIONS.

- e. Drain and let dry. Do not use a pipe cleaner as a drying tool because the lint from it will stick to the tube interior. Place the tube at an angle between a horizontal and a vertical surface (as between a shelf and a wall) with both ends open so air can flow through. Drying may be hastened by heat, as from a light bulb nearby. Do not blow through the tube as moisture from the breath will condense on the tube walls.
- f. To clean the float, pour about an inch of warm to hot (130-150°F) water into the cup containing the float. Grasp the float with tweezers and shake it side to side while submerged for a few seconds. Release the float. Repeat the action several times so all surfaces are washed. Hold the float with the tweezers, discard the wash water and repeat the above. A few drops of detergent will improve the process. Do not use your finger to hold the float.
- g. Allow the float to dry on a clean surface and then, with tweezers, place it in a clean dry cup.

NOTE: Do not attempt to dry the float with a rag or paper towel as electrostatic forces will make lint and other particles stick to the float.

- h. Clean stops with water as necessary. These may be handled with the fingers. Dry thoroughly before reassembly.
- i. When tube, float, and stops are clean and dry, reassemble as described in Section 2 - Installation. Proceed to paragraph 4.15, Cleaning V-Notch Plug.

4.9.4 Cleaning V-Notch Plug (See Dwgs. 25.200.000.020 and 25.200.000.030)

The same contaminants seen in the rotameter are in the gas stream flowing through the V-notch orifice and may also deposit at this point. When the rotameter is cleaned, clean the V-notch plug at the same time. If at any time float movement in the rotameter is not proportional to V-notch plug adjustment (a sudden marked rise or drop for a small amount of plug adjustment), the V-notch plug requires cleaning.

- a. Turn off the gas supply. After the gray knob drops down and the color indicator on the front of the vacuum regulator turns red and the rotameter float settles on the bottom stop, then shut off the injector water supply.
- b. Remove the V-notch assembly completely from the control unit.
- c. Using running water or a cup full of water and a small, stiff brush (such as a tooth brush), scrub out the V-notch groove and the shank of the plug. Do not use a knife, scraper or a file to clean out the groove. Dissolving action and scrubbing are all that are required.



WARNING: DO NOT USE HYDROCARBONS OR ALCOHOLS BECAUSE RESIDUAL SOLVENT MAY REACT WITH GAS. SOLVENTS CAN PRODUCE SERIOUS PHYSIOLOGICAL EFFECTS UNLESS USED IN STRICTEST COMPLIANCE WITH THE SOLVENT MANUFACTURER'S SAFETY RECOMMENDATIONS.

- d. Dry the plug with a clean cloth or paper towel.
- e. If an electric positioner is used, (see Dwg. 25.200.000.010) remove clamp nut (9) and extension chamber (7). Clean and inspect orifice (23) and O-rings (18 and 21) and replace if necessary.
- f. Wipe a thin film of Halocarbon grease on the threads of the V-notch extension chamber assembly. Reinstall it in the control unit, reconnect positioner and resume operation.

4.9.5 Cleaning Injector Throat and Tailway

Water containing carbonates, manganese or iron will frequently leave a deposit in injector tailways. As this deposit increases in thickness it can become scaly or rough and adversely affect pressure recovery or increase backpressure so that the injector fails to develop adequate operating vacuum. If the upstream strainer becomes corroded or perforated and passes a small pebble or other tramped material, such particles can partially plug the throat and prevent adequate flow. Water containing suspended silt or sand particles can erode the opening in the throat. As the opening becomes larger, the velocity developed is reduced and the vacuum decreases.

Deposits may be removed by immersing the throats in dilute (10%) hydrochloric acid, known commercially as muriatic acid.



WARNING: TO AVOID POSSIBLE SEVERE PERSONAL INJURY OR EQUIPMENT DAMAGE WHEN USING HYDROCHLORIC ACID, OBSERVE ALL SAFETY PRECAUTIONS RECOMMENDED BY THE ACID MANUFACTURER/SUPPLIER.

The injector should develop a dynamic vacuum of at least sixteen inches of mercury at maximum rotameter gas flow rate. At lower gas feed rates it tends to be higher for the same hydraulic conditions. With the gas completely shut off the static vacuum should be about 25 to 28 inches of mercury.

If the gas feeder fails to operate, inadequate vacuum is the most common reason and the injector is the first place to check. Proceed as described in paragraph 4.11, Troubleshooting.

4.9.6 Cleaning 3/4" Fixed Throat Injector (Standard) (See Dwg. 25.200.002.010)

The check valve prevents water from the injector from being drawn back into the control unit and toward the vacuum regulator during the OFF period, by the vacuum prevailing at shut-down.

In continuous or nearly continuous operation, this valve is actuated very little, and the recommended annual check is principally to assure cleanliness. In automatic start-stop operation, the check valve can accumulate thousands of opening and closing cycles in six months or less and wear becomes a consideration in addition to clean surfaces. For either interval the procedure is as follows:

- Cleaning Injector Unit Diaphragm Backcheck.
 - a. Shut off injector operating water.
 - b. Take steps to prevent water from the point of application, flowing back toward the injector.
 - c. Unscrew gas line tubing nut and remove tubing.
 - d. Unscrew injector body union nut.
 - e. Unscrew valve stem in the center of the top of the upper body. Wipe the surface of the spherical tip of valve stem with a clean cloth or paper towel to remove any loose material. Soak briefly in 10% muriatic (hydrochloric) acid if there are any deposits which do not wipe away in plain water. If the spherical surface is indented, worn, eroded, or scratched, replace valve stem.



WARNING: TO AVOID POSSIBLE SEVERE PERSONAL INJURY OR EQUIPMENT DAMAGE WHEN USING HYDROCHLORIC ACID, OBSERVE ALL SAFETY PRECAUTIONS RECOMMENDED BY THE ACID MANUFACTURER/SUPPLIER.

- f. Use a blunt tool, and remove the O-ring from the valve seat (diaphragm clamping screws). Discard the O-ring.
 - g. Reassemble the valve stem to the upper body and replace the valve seat O-ring and diaphragm clamping O-ring (outer) prior to assembling the injector body union nut.
- Cleaning Poppet Check
 - a. Unscrew the inlet adapter and discard O-ring.
 - b. Remove the poppet and remove the O-ring from the poppet. Discard the O-ring.

- c. Replace the poppet O-ring.
- d. Replace the inlet O-ring. Wipe a light film of Halocarbon grease on the O-ring before installing it.
- e. Reassemble the poppet and inlet adapter.

4.9.7 Cleaning 3/4" Fixed Throat Injector (Anti-Syphon) (See Dwg. 25.200.002.020)

The check valve prevents water from the injector from being drawn back into the control unit and toward the vacuum regulator during the OFF period, by the vacuum prevailing at shut-down.

In continuous or nearly continuous operation, this valve is actuated very little, and the recommended annual check is principally to assure cleanliness. In automatic start-stop operation, the check valve can accumulate thousands of opening and closing cycles in six months or less and wear becomes a consideration in addition to clean surfaces. For either interval the procedure is as follows:

- Cleaning Injector Unit Diaphragm Backcheck.
 - a. Shut off injector operating water.
 - b. Take steps to prevent water from the point of application, flowing back toward the injector.
 - c. Unscrew gas line tubing nut and remove tubing.
 - d. Unscrew injector body union nut.
 - e. Unscrew valve stem in the center of the top of the upper body. Wipe the surface of the spherical tip of valve stem with a clean cloth or paper towel to remove any loose material. Soak briefly in 10% muriatic (hydrochloric) acid if there are any deposits which do not wipe away in plain water. If the spherical surface is indented, worn, eroded, or scratched, replace valve stem.



WARNING: TO AVOID POSSIBLE SEVERE PERSONAL INJURY OR EQUIPMENT DAMAGE WHEN USING HYDROCHLORIC ACID, OBSERVE ALL SAFETY PRECAUTIONS RECOMMENDED BY THE ACID MANUFACTURER/SUPPLIER.

- f. Use a blunt tool, and remove the O-ring from the valve seat (diaphragm clamping screw). Discard the O-ring.
 - g. Reassemble the valve stem to the upper body and replace the valve seat O-ring and diaphragm clamping O-ring (outer) prior to assembling the injector body union nut.
- Cleaning Poppet Check

- a. Unscrew the inlet adapter and discard O-ring.
 - b. Remove the poppet and remove the O-ring from the poppet. Discard the O-ring.
 - c. Replace the poppet O-ring.
 - d. Replace the inlet O-ring. Wipe a light film of Halocarbon grease on the O-ring before installing it.
 - e. Reassemble the poppet and inlet adapter.
 - f. Proceed to paragraph c for anti-syphon portion of the injector.
- Cleaning Anti-Syphon Injector Lower Portion
 - a. Unscrew lower union nut and carefully remove bottom cap and take out diaphragm assembly. Clean off any deposits with warm (110-125°F) water. It is not necessary to disassemble the diaphragm unit to do this.
 - b. Clean O-ring groove on guide pins. Do not scrape with a knife blade or any such instrument. Only warm water (110-125°F) is permissible. Wipe a thin film of Halocarbon grease on the O-rings before installing them on the guide pins. Loosen screws 3/4 of a turn from their tight position, if disassembled.
 - c. Remove spring and wipe off any deposits found.
 - d. Reinstall spring and diaphragm assembly into bottom cap. Reassemble bottom cap to body with union nut.

4.9.8 Cleaning 1" Fixed Throat Injector (Standard) (See Dwg. 25.200.002.030)

- Cleaning Injector Unit Diaphragm Backcheck.
 - a. Shut off injector operating water.
 - b. Take steps to prevent water from the point of application, flowing back toward the injector.
 - c. Unscrew stem in the center of the top of the injector. Remove and discard O-ring.
 - d. Wipe the surface of the spherical tip of stem with a clean cloth or paper towel to remove any loose material. Soak briefly in 10% muriatic (hydrochloric) acid if there are any deposits which do not wipe away in plain water. If the spherical surface is indented, worn, eroded or scratched, replace valve stem.



WARNING: TO AVOID POSSIBLE SEVERE PERSONAL INJURY OR EQUIPMENT DAMAGE WHEN USING HYDROCHLORIC ACID, OBSERVE ALL SAFETY PRECAUTIONS RECOMMENDED BY THE ACID MANUFACTURER/SUPPLIER.

- e. Wipe a light film of Halocarbon grease on the O-ring before installing it on the stem.
- f. Look through the opening in the top of the injector with a flashlight and examine the conical hole and O-ring in diaphragm screw immediately below. If it is smooth and clean, merely reinstall the stem, making sure the large O-ring is under the head. If the conical hole and O-ring show film deposits, clinging particles, or a rough surface, disassemble the injector. Unscrew the gas line union nut and discard O-ring.
- g. Remove six bolts and lift off injector flange. Carefully remove the diaphragm assembly. Using a fine pointed tool, pierce the O-ring and remove it from the valve seat. Clean the conical hole in the diaphragm screw. Do not scrape with a knife blade or a tapered reamer. Scrub out with a cloth plug. Dissolve resistant deposit with 10% muriatic (hydrochloric) acid. It is not necessary to disassemble the diaphragm to do this.



WARNING: TO AVOID POSSIBLE SEVERE PERSONAL INJURY OR EQUIPMENT DAMAGE WHEN USING HYDROCHLORIC ACID, OBSERVE ALL SAFETY PRECAUTIONS RECOMMENDED BY THE ACID MANUFACTURER/SUPPLIER.

- h. Reassemble the valve stem to the upper body and replace the valve seat O-ring and diaphragm clamping O-ring (outer).
- i. Bolt the flange in place with six bolts.
- Cleaning Poppet Check
 - a. To clean poppet check unscrew adapter and remove O-ring. Discard the O-ring.
 - b. Remove poppet and remove O-ring. Discard the O-ring.
 - c. Clean threads and O-ring groove by soaking in warm water. Wipe a light film of Halocarbon grease on the O-ring and threads.
 - d. Install a new O-ring on the poppet and insert the poppet into the holder.
 - e. Assemble the holder to the injector body. Do not use excessive force when tightening the adapter.
 - f. Replace the union nut O-ring before reconnecting the gas line.

4.9.9 Cleaning 1" Fixed Throat Injector (Anti-Syphon) (See Dwg. 25.200.002.040)

NOTE: When removing O-rings, use a blunt tool to pull them out. Do not damage the tightening surfaces. Apply a thin film of Halocarbon grease to the new O-rings and to the threads.

- a. Remove the gas feeder from service. Remove all the gas from the tubing.
- b. Drain the operation water tubes.
- c. Follow the directions in Cleaning 1" Fixed Throat Injector (Standard) for steps c through i.
- d. Unscrew the clamping nut with the parts connected.
- e. Remove the poppet. Replace the O-ring.
- f. Remove the snap ring clip.
- g. Remove the clamping nut and spring.
- h. Remove the clamping washer and replace O-ring.
- i. Replace the diaphragm assembly. Assemble with clamping disc, clamping screw and spring. Secure with snap ring.
- j. Remove the plug and replace the O-ring.
- k. Press out the poppet seat. Replace the poppet seat along with the O-ring. Press in the new seat using a round rod or plastic tube (16 mm) with a flat front.
- l. Place the poppet into the guide and screw in the clamping nut with the assembled parts.
- m. Screw in the plug.
- n. Replace the O-ring in the gas inlet.
- o. Secure the tailway with the retaining nut and connect to the operation water tubing.
- p. Connect the gas line.
- q. Check for tightness and function.

4.10 Periodic Preventive Maintenance

Because of aging of elastomeric components and the desirability of checking internal zones for possible accumulations of deposits not seen in routine maintenance, it is recommended that at one-year intervals, each of the principal components of the system be completely disassembled. Before starting the work, ensure that the appropriate preventive maintenance kits are on hand.

NOTE: If the gas feeder is used seasonally (long-term shut-down) the maintenance should be performed prior to startup.

Refer to Section 6 of this book for appropriate kit numbers.

Disassembly and reassembly instructions necessary to install the maintenance kit parts are included in the kit(s).

Servicing of Evoqua Water Technologies equipment including installation of parts from maintenance kits should be restricted to trained, authorized personnel who are completely familiar with the entire contents of the equipment instruction book.

The Evoqua Water Technologies sales office or the dealer from whom you purchased the equipment can provide the preventive maintenance kits or overhaul service.

4.10.1 Testing of Remote Pressure Relief Valve

- a. Disconnect all tubing from the remote pressure relief valve.
- b. Connect a suitable length of tubing from the VENT half union to a container of water.
- c. Connect a manometer to the outlet connection.
- d. Apply pressure to the inlet with a squeeze bulb and note the manometer reading at which point bubbles appear in the water container. This pressure should be between 10 and 20 inches of water.

4.11 Troubleshooting

The following troubleshooting table is provided for determining and correcting most common troubles.

S10K V-NOTCH CHLORINATOR

Table 4.1 - Troubleshooting

<p>Basic Instructions:</p>	<p>1. Measure the vacuum over the full range of gas flow. (Low, half and full feed). 2. Compare what you measure with figures given below. If the figures are right, leave that component alone and check the next element. 3. Make additional checks (if necessary) to pin-point the problem. 4. Refer to detailed instructions for component disassembly and repair if this check list indicates such work is appropriate.</p>				
<p>WARNING: TO AVOID POSSIBLE SEVERE PERSONAL INJURY OR EQUIPMENT DAMAGE, TURN OFF THE GAS SUPPLY AT THE CONTAINER VALVE, WAIT UNTIL THE GRAY KNOB DROPS DOWN AND THE COLOR INDICATOR ON THE FRONT OF THE VACUUM REGULATOR TURNS RED AND THE ROTAMETER FLOAT RESTS ON THE BOTTOM STOP, AND THEN TURN OFF THE INJECTOR WATER SUPPLY BEFORE PERFORMING ANY DISASSEMBLY OPERATIONS.</p>					
OPERATING SYMPTOMS	PROBABLE CAUSE	WHAT TO MEASURE	HOW TO MEASURE	TYPICAL VALUES FOR PROPER OPERATION	REMEDY
<p>GAS FEEDER WILL NOT FEED AT ALL (NO ROTAMETER INDICATION) -OR- WILL NOT COME UP TO FULL FEED. (GAS SUPPLY TO GAS FEEDER IS NORMAL.)</p>	<p>Insufficient injector vacuum.</p>	<p>Injector vacuum</p>	<p>Connect vacuum gauge or mercury manometer to the plugged 1/4" port on the left side of the 1" fixed throat injector or to the 1/4" port on the front of the 3/4" fixed throat injector. If no gauge or manometer is available, remove line from differential regulating valve to injector. Turn on water supply and place wet thumb over inlet to injector. Vacuum should pull thumb down firmly and raise a "bump" on thumb.</p>	<p>Requires 16 inches of mercury, minimum, for dynamic (gas flowing) conditions. With gas shut off, should see 25 to 28 inches of mercury static vacuum.</p>	<p>Remove throat and tailway and clean or (if necessary) replace. Clean Y-strainer in water line. Check solution discharge line for accumulation of foreign material, hose kinks, or partially closed valve. With gauges, measure operating water pressure and pressure at point of application. Compare with previous data. If system has a booster pump, check pump for wear, buildup of deposits, and air leaks. If it is a new installation, ensure that there is no elbow or reducing coupling immediately downstream of injector tailway. Run full size pipe straight up at least 8" before any elbow or reducer, or use poly pipe and arrange in a smooth curve, up, over and down, as required.</p>

S10K V-NOTCH CHLORINATOR

Table 4.1 - Troubleshooting (Cont'd)

OPERATING SYMPTOMS	PROBABLE CAUSE	WHAT TO MEASURE	HOW TO MEASURE	TYPICAL VALUES FOR PROPER OPERATION	REMEDY
GAS FEEDS NORMALLY AT HIGH RATES, BUT WILL NOT CONTROL AT LOW RATES.	Vacuum regulator not throttling sufficiently (held open by a particle of ferric chloride, rust, or dirt etc.); too much gas flowing.	Gas inlet vacuum. (Probably too low at low feed rates.)	Connect a tee and a single leg manometer at the vacuum regulator outlet.	13 to 40 inches of water vacuum.	Clean vacuum regulator. (See separate instruction book.
ROTAMETER FLOAT DOES NOT DROP ALL THE WAY TO THE BOTTOM STOP WHEN THE GAS IS SHUT OFF AT THE CYLINDER AND THE INJECTOR IS OPERATING.	Air leak upstream of rotameter -OR - dirty rotameter.	See if float is spinning or free floating (indicating air flow) or it drops to a constant point and is dead (indicating binding by dirt or foreign matter).	Visual appearance.	---	Check vacuum regulator diaphragms, including center seals. (See separate instruction book.) Clean the rotameter.

S10K V-NOTCH CHLORINATOR

Table 4.1 - Troubleshooting (Cont'd)

OPERATING SYMPTOMS	PROBABLE CAUSE	WHAT TO MEASURE	HOW TO MEASURE	TYPICAL VALUES FOR PROPER OPERATION	REMEDY
ROTAMETER FLOAT DOES NOT RISE AND FALL UNIFORMLY IN PROPORTION TO V-NOTCH KNOB ROTATION BUT JUMPS UP OR DOWN SHARPLY WITH A SMALL CHANGE IN V-NOTCH SETTING.	Contamination in V-notch plug.	-	Visual.	---	Remove V-notch assembly and clean V-shaped groove in V-notch plug. (A toothbrush and warm water are usually effective). CAUTION: Do not scrape or scratch groove with a sharp-edged tool.
NO INJECTOR VACUUM AT GAS INLET TO INJECTOR. OPERATING WATER PRESSURE AND DISCHARGE PRESSURE BOTH NORMAL. INJECTOR THROAT AND TAILWAY CLEAN. O-RING GOOD. LINE TO POINT OF APPLICATION IS CLEAR.	Injector check valve not opening.	See if air is leaking into injector. -OR- Check for water leaking from rear of anti-syphon injector.	Visual.	There should be no air entering. -OR- There should be no water leaking from injector.	Replace parts as necessary. -OR- Disassemble injector and examine diaphragms. Replace parts as necessary.

S10K V-NOTCH CHLORINATOR

Table 4.1 - Troubleshooting (Cont'd)

OPERATING SYMPTOMS	PROBABLE CAUSE	WHAT TO MEASURE	HOW TO MEASURE	TYPICAL VALUES FOR PROPER OPERATION	REMEDY
V-NOTCH IS DIFFICULT TO TURN. WHEN FORCIBLY MOVED, AN AIR LEAK IS DETECTED.	Buildup of contaminant residue on V-notch plug shaft is binding in the seal -OR- has been forced past the seal, stretching it open.	No measurements required.	---	---	Remove entire V-notch assembly. Soak in warm water for about two minutes. Clean plug. Lubricate O-ring or seal with a light film of Halocarbon grease. Reassemble all parts, tightening automatic seal clamp (if applicable) just enough to give a smooth, firm, sliding grip on the plug. Replace seal if damaged. Replace orifice if stretched open.
GAS FEEDER FEEDS NORMALLY, BUT CYLINDER WEIGHT LOSS AS SHOWN BY SCALE DOES NOT AGREE WITH ROTAMETER INDICATIONS MULTIPLIED BY TIME AT EACH SETTING.	Air leak upstream of rotameter.	---	---	---	For air leaks, check: vacuum regulator diaphragm(s), including center seals and tubing connectors. (See separate instruction book.)

S10K V-NOTCH CHLORINATOR

WARNING LABELS AND TAGS

The following warning labels are attached to the equipment:

ACG4600: THIS UNIT IS DESIGNED TO OPERATE UNDER VACUUM ONLY. TO AVOID POSSIBLE SEVERE PERSONAL INJURY OR DAMAGE TO EQUIPMENT, DO NOT CONNECT TO A SOURCE OF GAS UNDER PRESSURE. SEE INSTRUCTION BOOK FOR FULL DETAILS BEFORE INSTALLATION.

AAA2595: INITIAL INSTALLATION & CHECK-OUT OF THIS EQUIPMENT MUST BE MADE FOLLOWING DETAILED INSTRUCTIONS CONTAINED IN THE EVOQUA WATER TECHNOLOGIES INSTRUCTION BOOK & SAFETY RELATED INFORMATION OBTAINED FROM YOUR GAS SUPPLIER. THESE CONDENSED OPERATING INSTRUCTIONS MAY THEN BE FOLLOWED FOR SUBSEQUENT GUIDANCE OF TRAINED EQUIPMENT OPERATORS.

AHS4646: HAZARDOUS GAS IS PRESENT IN THIS EQUIPMENT DURING NORMAL OPERATION. TO AVOID POSSIBLE SEVERE PERSONAL INJURY OR DAMAGE TO THE EQUIPMENT, READ THE EVOQUA WATER TECHNOLOGIES INSTRUCTION BOOK AND THE APPROPRIATE GAS MANUAL BEFORE CONNECTING THIS EQUIPMENT TO A SUPPLY OF GAS. OPERATION AND MAINTENANCE OF THIS EQUIPMENT MUST BE RESTRICTED TO TRAINED, QUALIFIED PERSONNEL WHO ARE COMPLETELY FAMILIAR WITH THESE INSTRUCTIONS.

CAUTION LABELS AND TAGS

The following caution labels and tags are attached to the equipment:

AFM4743: FOR CHLORINE, SULFUR DIOXIDE, AMMONIA OR CARBON DIOXIDE USE ONLY.

ADH4733: FOR CHLORINE, SULFUR DIOXIDE OR CARBON DIOXIDE USE ONLY.

S10K V-NOTCH CHLORINATOR

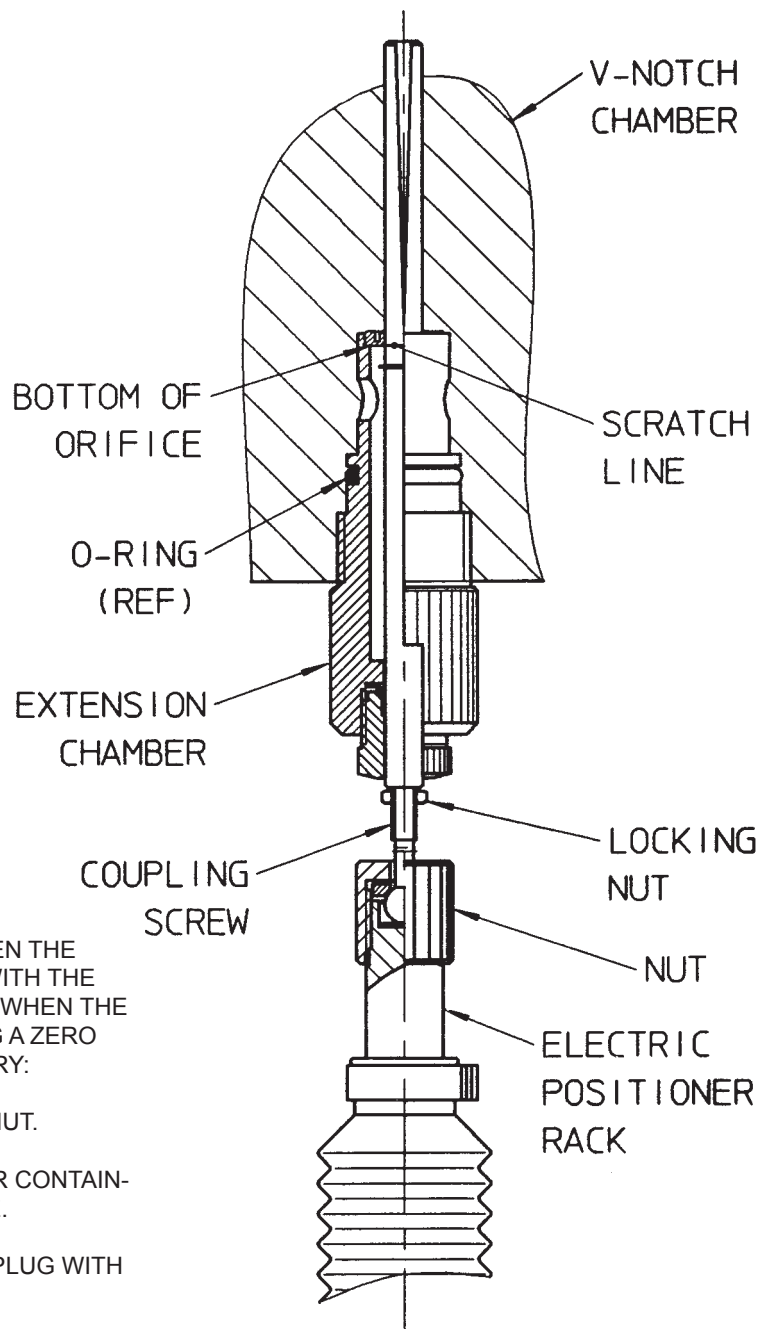

THE PLUG IS AT THE ZERO POSITION WHEN THE SCRATCH LINE ON THE PLUG IS IN LINE WITH THE BOTTOM OF THE ORIFICE. THIS RESULTS WHEN THE ELECTRONIC CONTROLLER IS RECEIVING A ZERO SIGNAL. IF ADJUSTMENTS ARE NECESSARY:

- A. RETRACT RACK AND THEN LOOSEN NUT.
- B. UNSCREW THE EXTENSION CHAMBER CONTAINING THE V-NOTCH PLUG AND ORIFICE.
- C. LINE UP THE SCRATCH LINE ON THE PLUG WITH THE BOTTOM OF THE ORIFICE.
- D. CAREFULLY REINSTALL THE EXTENSION CHAMBER INTO THE UNIT.
- E. LOOSEN LOCKING NUT AND SCREW COUPLING SCREW COMPLETELY IN.
- F. USE ELECTRICAL SIGNAL FROM CONTROLLER TO POSITION RACK AT ZERO FEED POSITION.
- G. ADJUST BALL AND SCREW FOR CORRECT ALIGNMENT BETWEEN THE ACTUATOR AND THE PLUG.
- H. ATTACH THE NUT AND TIGHTEN.

AUTOMATIC CONTROL UNIT - SERVICE
Zero Position of Plug

25.200.150.010

ISSUE 0 10-95

SECTION 5

S10K V-NOTCH CHLORINATOR

SECTION 5 - ILLUSTRATIONS

List Of Contents

	DRAWING NO.
Parts	
S10K Control Panel	25.200.000.010A&B
Master Control Unit and Indicating Unit	
3-Inch	25.200.000.020A&B
5-Inch	25.200.000.030A&B
3" Rotameter Components	25.200.001.010A&B
5" Rotameter Components	25.200.001.020A&B
V-Notch Plugs	25.200.001.030
AAA4310 3/4" Standard Injector	25.200.002.010A&B
AAA4307 3/4" Anti-Syphon Injector.....	25.200.002.020A&B
AAA4316 1" Standard Injector	25.200.002.030A&B
AAA4313 1" Anti-Syphon Injector	25.200.002.040A&B
Plastic 1" Fixed Throat Injector and Tailway	
Details	25.200.003.010A&B
Plastic Main Connection.....	50.845.06.011
Main Connection - For 1-1/2" Solution Line	50.845.006.021
Main Connections - For Hose	50.845.02.011

S10K V-NOTCH CHLORINATOR

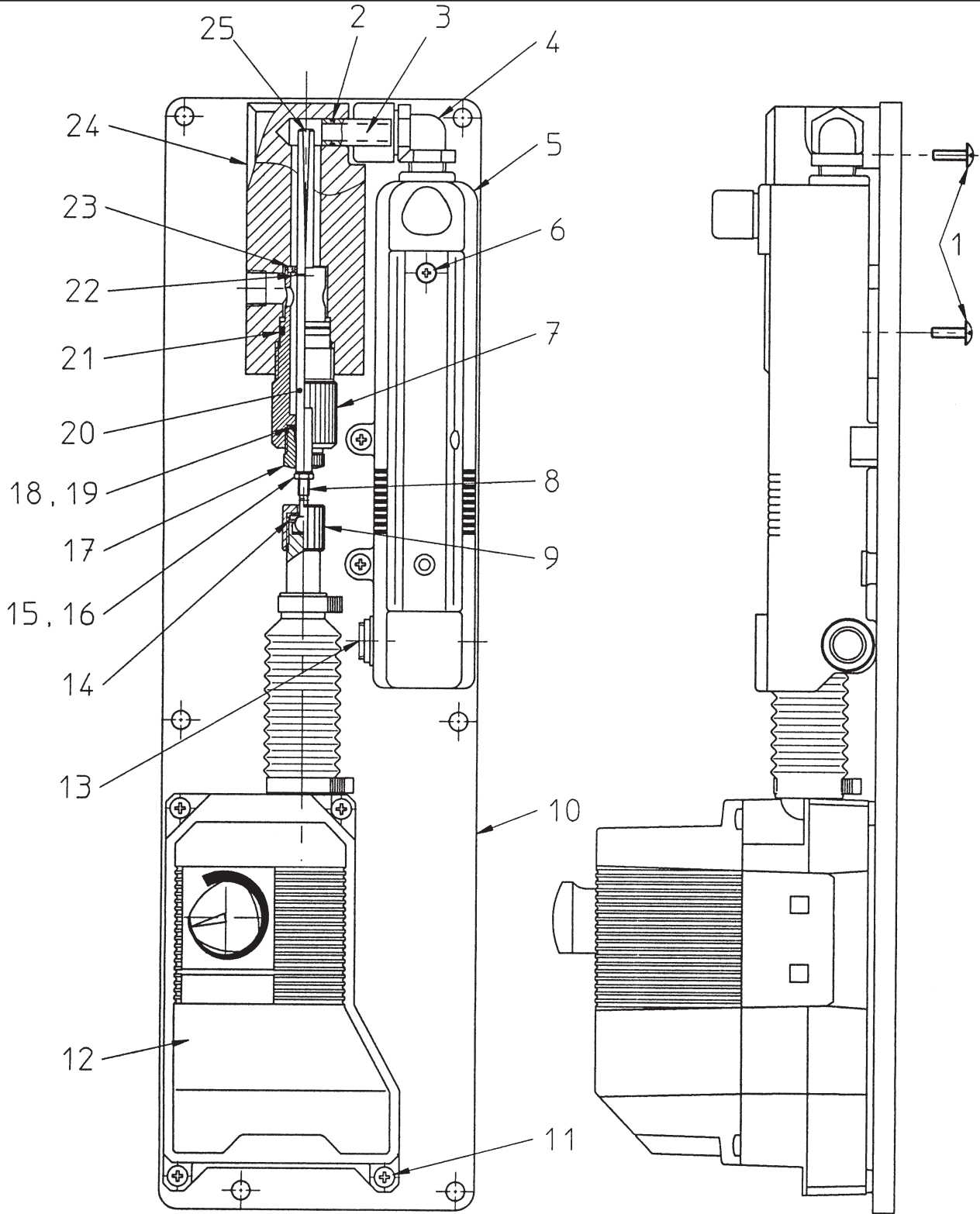

AAA1085 S10K CONTROL PANEL - PARTS
Automatic Arrangement

NOTE: FOR PARTS LIST, SEE DWG. 25.200.000.010B.

25.200.000.010A

ISSUE 0 10-95

S10K V-NOTCH CHLORINATOR

KEY NO.	PART NO.	QTY.	DESCRIPTION
1	AAA2607	2	MACH.SCREW (TRUSS HD., SST) M6 x 20 MM LG.
2	PXH39648	1	O-RING (014) HYPALON, 1/2" ID x 5/8" OD
3	AMK4267	1	TUBE-CONNECTOR
4	U24110	1	ELBOW
5	----	1	HOUSING ASSY. - 5" ROTAMETER (SEE DWG. 25.200.000.030)
6	AAA2565	1	MACH. SCREW (FLAT HEAD, SIL. BRZ.) M3 x 5 MM LG.
7	P52146	1	EXTENSION CHAMBER
8	P97027	1	BALL & SCREW
9	P97026	1	NUT, CLAMP
10	AKG4013	1	MOUNTING PLATE
11	AAA2568	4	MACH. SCREW (PAN HEAD) (SIL. BRZ.) M3 x 5 MM LG.
12	----	1	POSITIONER (SEE SEPARATE INSTRUCTION BOOK)
13	P52090	1	PLUG, PIPE (1/2-14) BLK POLYETHYLENE
14	P97028	1	WASHER, BALL
15	P16542	1	HEX. NUT (MONEL) 1/4-20
16	P16556	1	FLAT WASHER (MONEL) 1/4"
17	P37663	1	CLAMPING SCREW
18	PXH26482	1	O-RING (012) HYPALON, 3/8" ID x 1/2" OD
19	P34530	1	SEAL SHAFT (TEFLON)
20	AAA4484	1	STEM/STUD UNIT
21	P44045	1	O-RING (213) HYPALON, 15/16" ID x 1-3/16" OD
22	P36861	1	1/2" WASHER (TEFLON)
23	P37657	1	ORIFICE
24	AMK5115	1	V-NOTCH CHAMBER
25	----	1	V-NOTCH PLUG (SEE DWG. 25.200.001.030)

WHEN ORDERING MATERIAL, ALWAYS SPECIFY MODEL AND SERIAL NUMBER OF APPARATUS.

AAA1085 S10K CONTROL PANEL - PARTS LIST
Automatic Arrangement

25.200.000.010B

ISSUE 1 7-04

S10K V-NOTCH CHLORINATOR

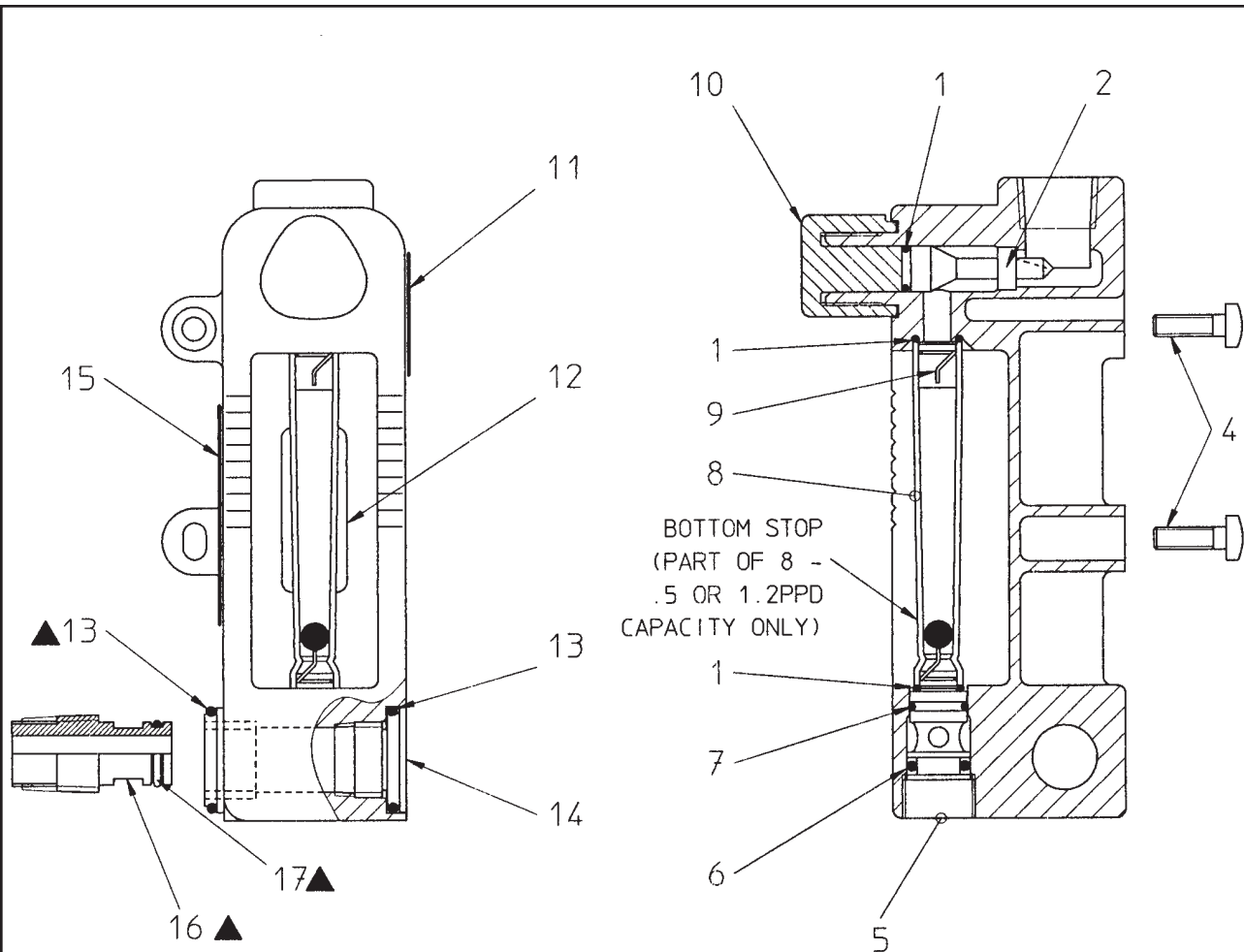

NOTE: ▲ USED ONLY WHEN UNIT IS MOUNTED ON VACUUM REGULATOR.
 FOR PARTS LIST, SEE DWG. 25.200.000.020B.

ANM4122 MASTER CONTROL UNIT AND AAA1385 INDICATING UNIT - PARTS
 3-Inch

25.200.000.020A

ISSUE 3 1-09

S10K V-NOTCH CHLORINATOR

KEY NO.	PART NO.	QTY.	DESCRIPTION
1	PXH26482	3	O-RING (012) HYPALON, 3/8" ID x 1/2" OD
■ 2	P59143	1	V-NOTCH PLUG SEAL
4	AUK3460	2	MACH. SCREW (RD. HD., PHIL., SIL. BRZ.) M6 x 20 MM LG.
5	ARQ4515	1	JACK-SCREW
6	AMK5536	1	O-RING (205) HYPALON, 7/16"ID x 11/16" OD
7	PXH39648	1	O-RING (014) HYPALON, 1/2" ID x 5/8" OD
8	---	1	3" ROTAMETER COMPONENTS (SEE DWG. 25 200.001.010)
9	AAB2297	1	STOP FLOAT, SPRING TYPE
10	ALE4464	1	KNOB
11	AHS4646	1	WARNING LABEL
12	AFM4743	1	CAUTION LABEL
13	P44123	2	O-RING (120) HYPALON, 1" ID x 1-3/16" OD
	OR		
	▲ P44123	1	O-RING (120) HYPALON, 1" ID x 1-3/16" OD
14	ANI4501	1	1/2" NPT PLUG
15	ACG4600	1	WARNING LABEL
○▲ 16	AAA3491	1	CONNECTOR
○▲ 17	PXH26345	1	O-RING

NOTE:

- NOT PART OF INDICATING UNIT.
- ▲ USED ONLY WHEN UNIT IS MOUNTED ON VACUUM REGULATOR.
- NOT PART OF ASSEMBLY. ORDER SEPARATELY IF REQUIRED.

WHEN ORDERING MATERIAL, ALWAYS SPECIFY MODEL AND SERIAL NUMBER OF APPARATUS.

ANM4122 MASTER CONTROL UNIT AND AAA1385 INDICATING UNIT - PARTS LIST
3-Inch

25.200.000.020B

ISSUE 4 1-09

S10K V-NOTCH CHLORINATOR

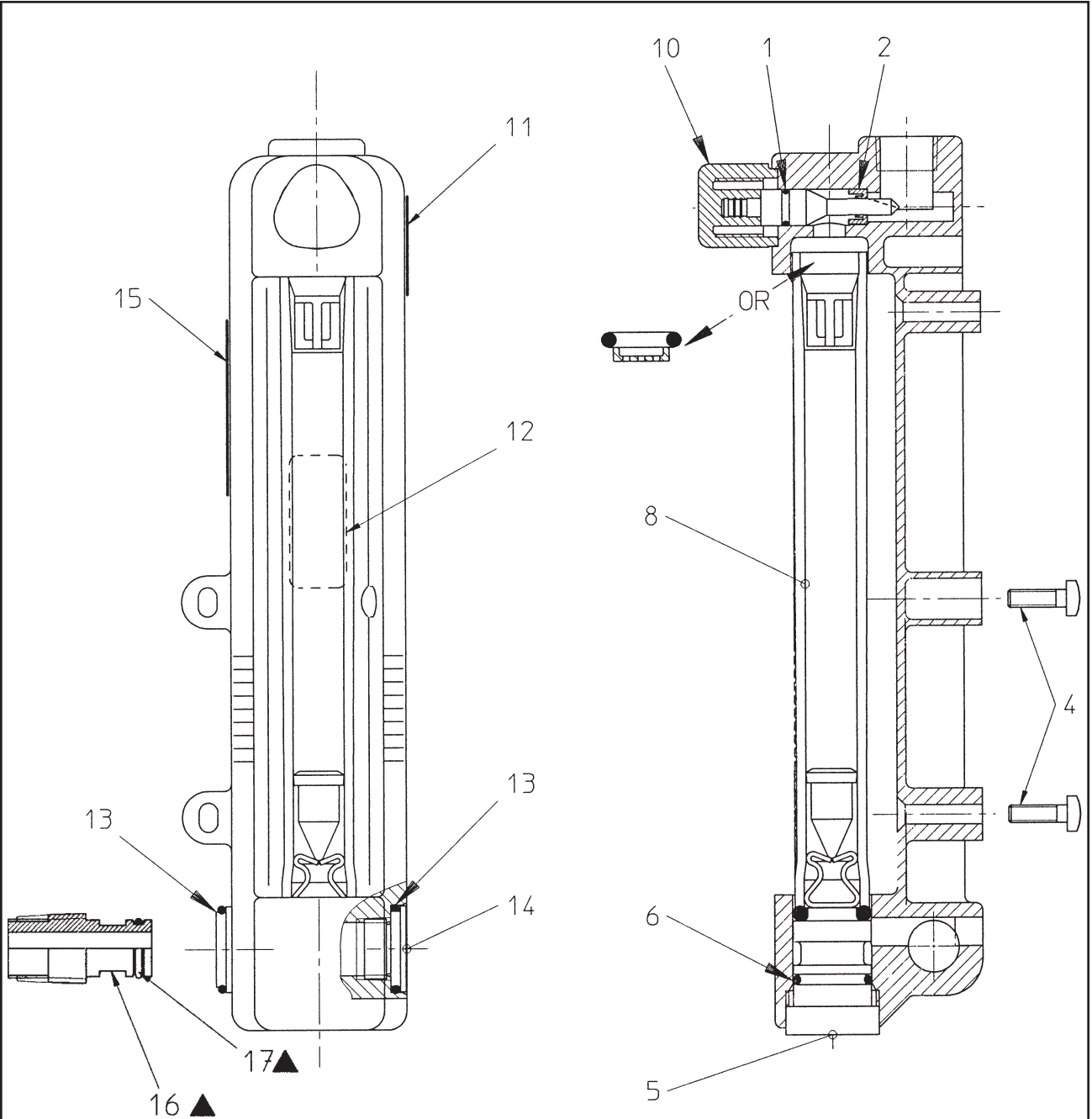

NOTE: ▲ USED ONLY WHEN UNIT IS MOUNTED ON VACUUM REGULATOR.
 FOR PARTS LIST, SEE DWG. 25.200.000.030B.

ANM4127 MASTER CONTROL UNIT AND AAA1382 INDICATING UNIT - PARTS
 5-Inch

25.200.000.030A

ISSUE 4 1-09

S10K V-NOTCH CHLORINATOR

KEY NO.	PART NO.	QTY.	DESCRIPTION
1	PXH26482	1	O-RING (012) HYPALON, 3/8" ID x 1/2" OD
■ 2	P59143	1	V-NOTCH PLUG SEAL
4	AUK3460	2	MACH. SCREW (RD. HD., PHIL., SIL. BRZ.) M6 x 20 MM LG.
5	AOK4510	1	JACK-SCREW
6	PXH40040	1	O-RING (118) HYPALON, 7/8" ID x 1-1/16" OD
8	----	1	5" ROTAMETER COMPONENTS (SEE DWG. 25.200.001.020A&B)
10	ALE4464	1	KNOB
11	AHS4646	1	WARNING LABEL
12	AFM4743	1	CAUTION LABEL
13	P44123	2	O-RING (120) HYPALON, 1" ID x 1-3/16" OD
14	ANI4501	1	1/2" NPT PLUG
15	ACG4600	1	WARNING LABEL
○▲ 16	AAA3491	1	CONNECTOR
○▲ 17	PXH26345	1	O-RING

NOTE:

- NOT PART OF INDICATING UNIT.
- ▲ USED ONLY WHEN UNIT IS MOUNTED ON VACUUM REGULATOR.
- NOT PART OF ASSEMBLY. ORDER SEPARATELY IF REQUIRED.

WHEN ORDERING MATERIAL, ALWAYS SPECIFY MODEL AND SERIAL NUMBER OF APPARATUS.

ANM4127 MASTER CONTROL UNIT AND AAA1382 INDICATING UNIT - PARTS LIST
5-Inch

25.200.000.030B

ISSUE 3 1-09

S10K V-NOTCH CHLORINATOR

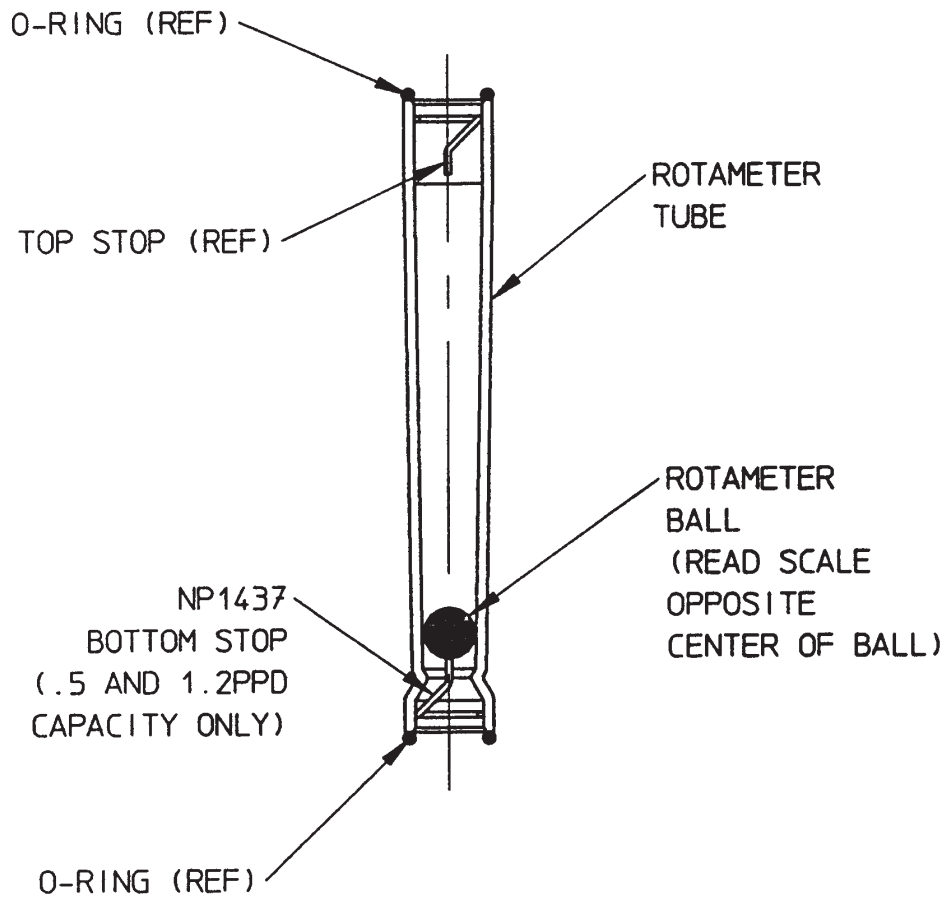

NOTE: FOR PARTS LIST, SEE DWG. 25.200.001.010B.

WHEN ORDERING MATERIAL, ALWAYS SPECIFY MODEL AND SERIAL NUMBER OF APPARATUS.

3" ROTAMETER COMPONENTS - PARTS

25.200.001.010A

ISSUE 0 10-95

S10K V-NOTCH CHLORINATOR

CHLORINE (SINGLE SCALE)

MAX. CAP. LB./24 HR.	ROTAMETER TUBE ONLY	ROTAMETER BALL ONLY	ROTAMETER TUBE & BALL
1.2	P 47335	P 43117	▲ UXF 21741
4	PXB 44944	NPXA 148	UXL 21741
1.0	PXB 44945	NPXA 149	UXJ 21741
20	PXB 44946	NPXA 149	UXK 21741
50	PXB 44947	NPXA 150	UXH 21741
100	PXB 44948	NPXA 151	UXG 21741
150	PXA 52049	NPXA 151	UXC 2494I
200	P 52048	P 37706	UXB 2494I

SULFUR DIOXIDE (SINGLE SCALE)

MAX. CAP. LB./24 HR.	ROTAMETER TUBE ONLY	ROTAMETER BALL ONLY	ROTAMETER TUBE & BALL
1.2	P 54264	P 43117	▲ U 26240
4	P 54263	NPXA 148	U 26239
1.0	P 54262	NPXA 149	U 26238
20	P 54261	NPXA 149	U 26237
50	P 54260	NPXA 150	U 26236
100	P 54405	NPXA 151	U 26235
150	P 54404	NPXA 151	U 26234
200	P 54403	P 37706	U 26233

AMMONIA (SINGLE SCALE)

MAX. CAP. LB./24 HR.	ROTAMETER TUBE ONLY	ROTAMETER BALL ONLY	ROTAMETER TUBE & BALL
0.5	AJA 3984	P 43117	▲ AAA 1058
2	AJE 3989	NPXA 146	AAA 1064
5	AMK 3994	NPXA 148	AAA 1067
9	ANM 3998	NPXA 149	AAA 1070
25	APP 4002	NPXA 150	AAA 1073
50	ALJ 4006	NPXA 151	AAA 1076
70	ALJ 4010	NPXA 151	AAA 1079
100	AKG 4016	P 37706	AAA 1082

NOTE: ▲ INCLUDES TWO STOPS NP1437.
CONSULT EVOQUA WATER TECHNOLOGIES FOR CARBON DIOXIDE ROTAMETERS.

WHEN ORDERING MATERIAL, ALWAYS SPECIFY MODEL AND SERIAL NUMBER OF APPARATUS.

3" ROTAMETER COMPONENTS - PARTS LIST

25.200.001.010B

ISSUE 1 6-14

S10K V-NOTCH CHLORINATOR

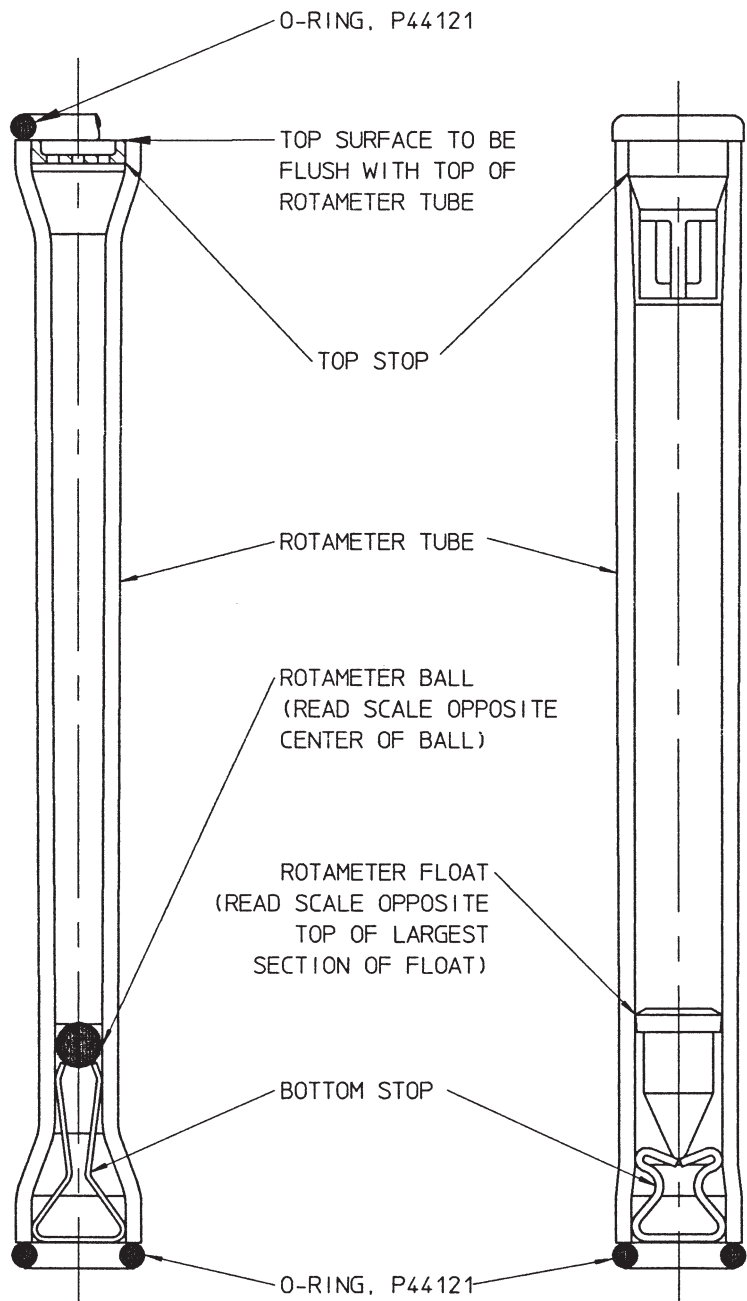

3 TO 150PPD

200 TO 500PPD

NOTE: FOR PARTS LIST, SEE DWG. 25.200.001.020B.

5" ROTAMETER COMPONENTS - PARTS
For Chlorine Use

25.200.001.020A

ISSUE 0 10-95

S10K V-NOTCH CHLORINATOR

ROTAMETER						
MAXIMUM CAPACITY LBS. PER 24 HRS.	COMPLETE UNIT	TUBE	FLOATS		STOPS	
			PART NUMBER	DESCRIPTION	TOP	BOTTOM
3	UXA 25054	P 52148	P 37702	1/8" DIA. RED BALL	P 41212	P 38131
10	UXB 25054	P 52150	P 37702	1/8" DIA. RED BALL	P 41212	P 38131
20	UXC 25054	P 52152	P 37703	5/32" DIA. RED BALL	P 41212	P 38131
30	UXP 25054	PXA 52154	NPXA 150	1/4" DIA. BLACK BALL	P 41212	P 38131
50	UXE 25054	P 52156	P 37705	1/4" DIA. RED BALL	P 41212	P 38131
75	UXF 25054	P 52158	P 37706	5/16" DIA. RED BALL	P 41212	P 38131
100	UXG 25054	P 52160	P 37706	5/16" DIA. RED BALL	P 41212	P 38131
150	UXH 25054	P 52162	P 37707	3/8" DIA. RED BALL	P 41212	P 38131
200	UXJ 25054	P 52164	P 36376	9/16" DIA. GLASS FLOAT	AIC 5506	P 48140
250	UXK 25054	P 52166	P 36376	9/16" DIA. GLASS FLOAT	AIC 5506	P 48140
300	UXL 25054	P 52168	P 38256	5/8" DIA. GLASS FLOAT	AIC 5506	P 48140
400	UXM 25054	P 52170	P 38256	5/8" DIA. GLASS FLOAT	AIC 5506	P 48140
500	UXN 25054	P 52172	P 35103	11/16" DIA. CERAMIC FLOAT	AIC 5506	P 48140

WHEN ORDERING MATERIAL, ALWAYS SPECIFY MODEL AND SERIAL NUMBER OF APPARATUS.

5" ROTAMETER COMPONENTS - PARTS LIST
For Chlorine Use

25.200.001.020B

ISSUE 0 10-95

S10K V-NOTCH CHLORINATOR

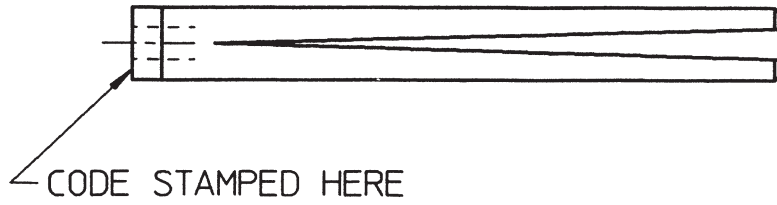

CAPACITY (LB/24 HR) n				V-NOTCH PLUG		
Cl ₂	SO ₂	NH ₃	CO ₂	PART NO.	CODE	NO. OF GROOVES
10	10	4.5	8	ALI 3595	10	1
20	20	9	15	AKG 3601	20	1
30	30	14	24	PXA 39598	P	1
50	50	24	35	APS 3605	50	1
75	75	35	58	PXC 39598	R	1
100	100	45	75	AJE 3801	1C	1
150	150	70	116	PXD 39598	S	1
200	200	95	150	PXE 39598	T	1
250	250	120	200	PXF 39598	U	1
300	300	140	230	APQ 3806	3C	1
400	400	190	300	PXG 39598	V	1
500	475	240	390	PXH 39598	W	2

NOTE: ■ Cl₂ - CHLORINE, SO₂ - SULFUR DIOXIDE, NH₃ - AMMONIA, CO₂ - CARBON DIOXIDE.

WHEN ORDERING MATERIAL, ALWAYS SPECIFY MODEL AND SERIAL NUMBER OF APPARATUS.

V-NOTCH PLUGS - PARTS
S10K Automatic Arrangement

25.200.001.030

ISSUE 0 10-95

S10K V-NOTCH CHLORINATOR

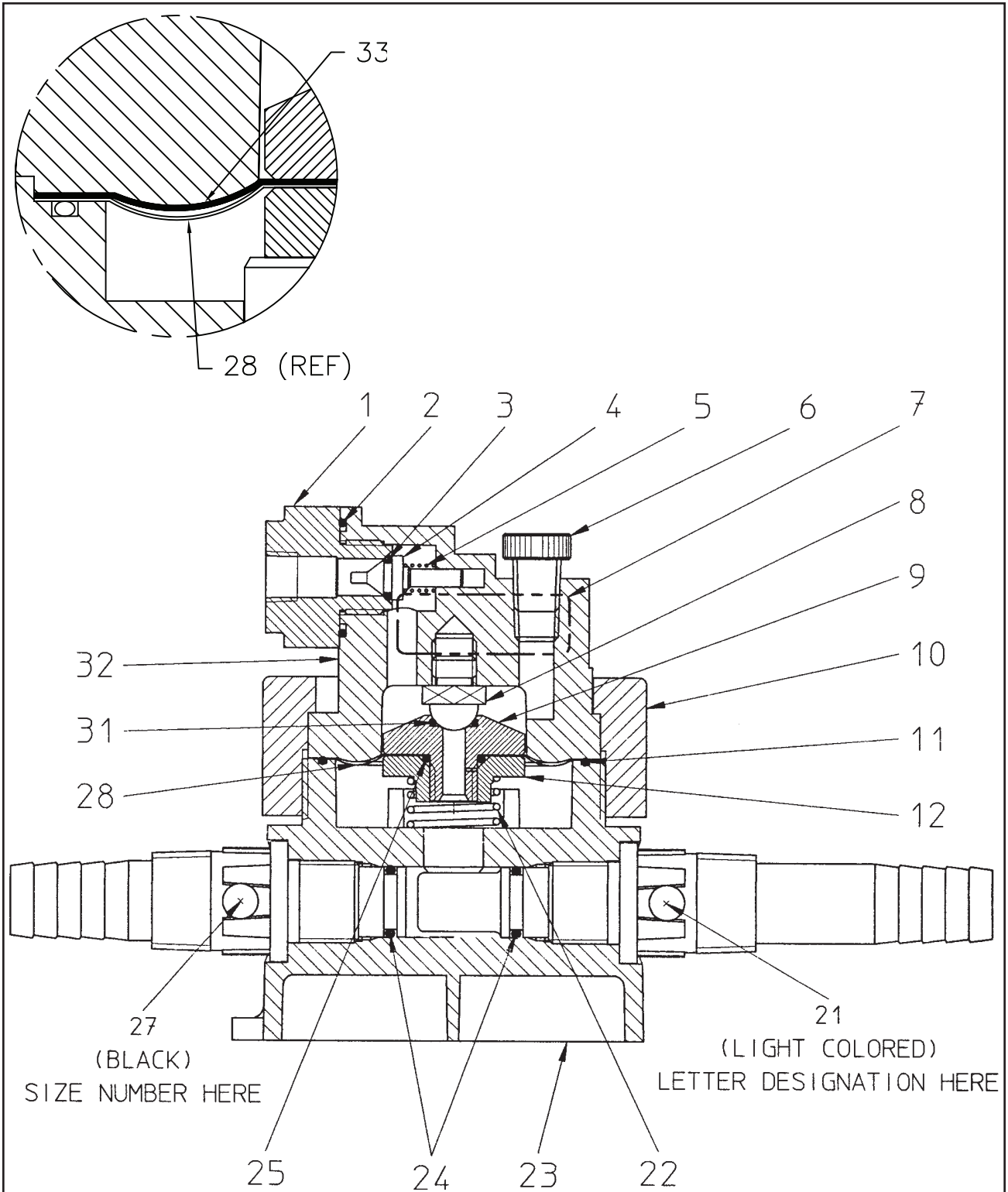

NOTE: FOR PARTS LIST, SEE DWG. 25.200.002.010B.

AAA4310 3/4" STANDARD INJECTOR - PARTS

25.200.002.010A

ISSUE 2 5-04

S10K V-NOTCH CHLORINATOR

KEY NO.	PART NO.	QTY.	DESCRIPTION
1	AAA1547	1	INLET/POPPET SEAT 1/4" NPT
2	PXA41332	1	O-RING (120) VITON, 1" ID x 1-3/16" OD
3	ANM3591	1	O-RING, POPPET
4	P97032	1	POPPET
5	P48655	1	SPRING, POPPET CK.
6	P31295	1	PLUG, 1/4 NPT
7	ADH4733	1	CAUTION LABEL
8	P97034	1	STEM
9	AAB4087	1	VALVE SEAT
10	P97164	1	UNION NUT
11	P94729	1	O-RING
12	AAB4090	1	NUT
21	(SEE TABLE)	1	TAILWAY
22	P48976	1	SPRING
23	P96972	1	LOWER BODY
24	PXA27409	2	O-RING (113) 9/16" ID x 3/4" OD
25	PXA26482	1	O-RING, DIAPH. CHECK
27	(SEE TABLE)	1	NOZZLE
28	P97063	1	DIAPHRAGM, TEFLON
31	P97342	1	O-RING, VITON
32	P96973	1	UPPER BODY
33	AAA4325	1	DIAPHRAGM, VITON

(21) TAILWAY	CODE
PXB 48962	B
PXC 48962	C
PXD 48962	D
PXE 48962	E
PXF 48962	F
PXG 48962	G
PXH 48962	H
PXJ 48962	J
PXS 48962	S

(27) NOZZLE	SIZE NO.
PXC 48961	70
PXD 48961	84
PXE 48961	99
PXF 48961	120
PXG 48961	140
PXH 48961	165
PXJ 48961	193
PXK 48961	242

WHEN ORDERING MATERIAL, ALWAYS SPECIFY MODEL AND SERIAL NUMBER OF APPARATUS.

AAA4310 3/4" STANDARD INJECTOR - PARTS LIST

25.200.002.010B

ISSUE 4 4-05

S10K V-NOTCH CHLORINATOR

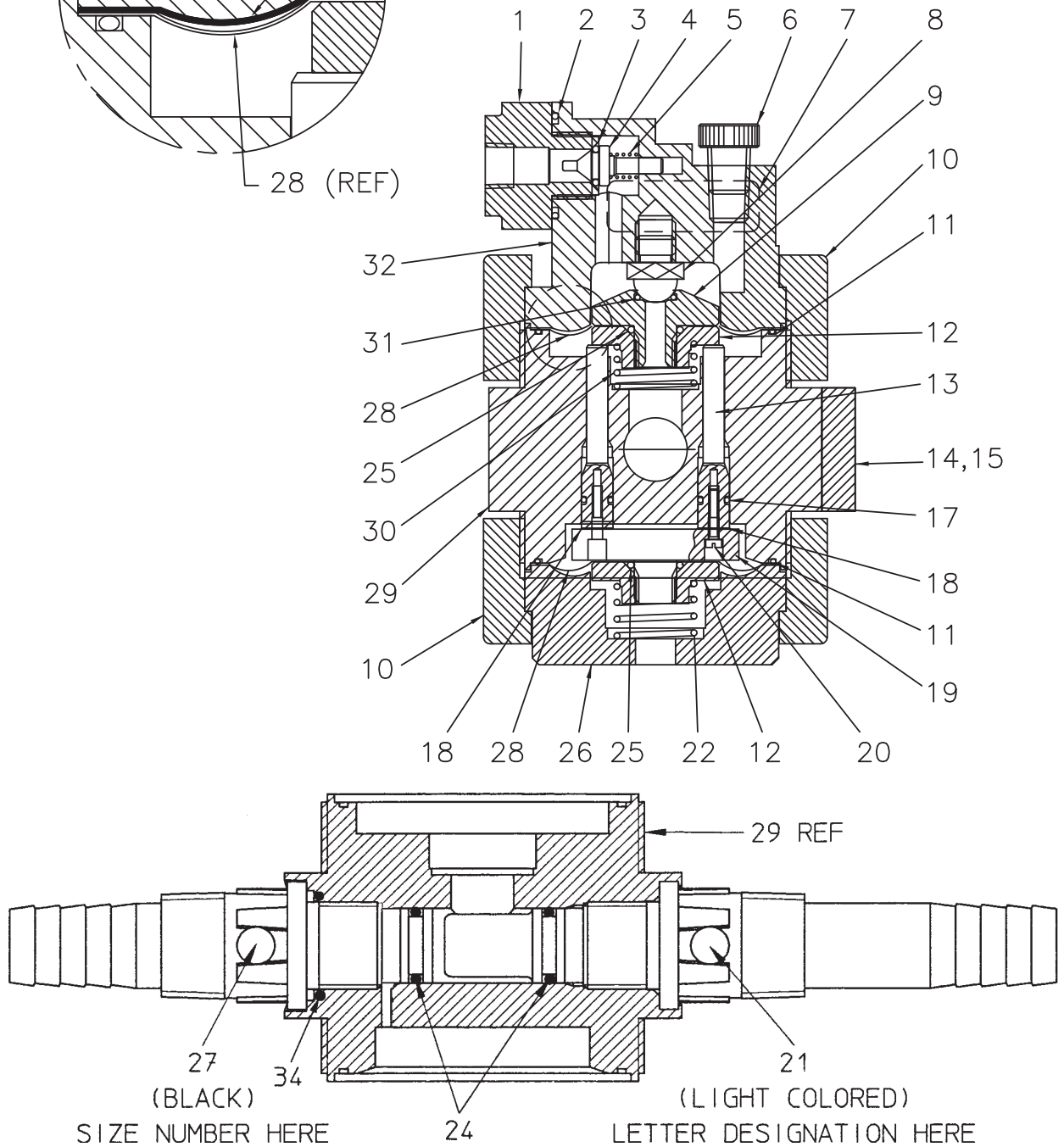
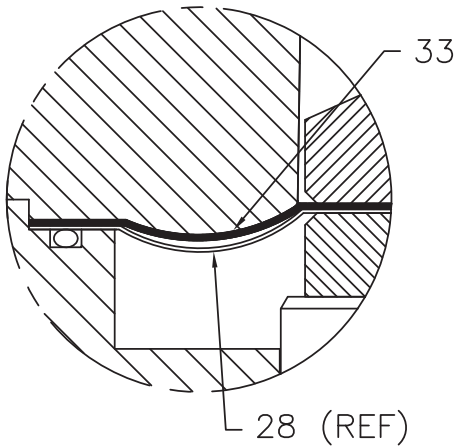

NOTE: FOR PARTS LIST, SEE DWG. 25.200.002.020B.

AAA4307 3/4" ANTI-SYPHON INJECTOR - PARTS

25.200.002.020A

ISSUE 5 1-09

S10K V-NOTCH CHLORINATOR

KEY NO.	PART NO.	QTY.	DESCRIPTION
1	AAA1547	1	INLET/POPPET SEAT 1/4" NPT
2	PXA41332	1	O-RING (120) VITON, 1" ID x 1-3/16" OD
3	ANM3591	1	O-RING, POPPET
4	P97032	1	POPPET
5	P48655	1	SPRING, CK. VALVE
6	P31295	1	PLUG, PVC, 1/4" NPT
7	ADH4733	1	CAUTION LABEL
8	P97034	1	VALVE STEM
9	AAB4087	1	VALVE SEAT
10	P97164	2	UNION NUT
11	P94729	2	O-RING
12	AAB4090	2	NUT
13	P97035	2	GUIDE PIN
14	P97038	1	BRACKET
15	P100178	2	SCREW, M6
17	PXA25900	2	O-RING (010) VITON, 1/4" ID x 3/8" OD
18	P52006	2	WASHER
19	P97037	1	BACKING PLATE
20	P33847	2	MACH. SCREW (SILVER) #4-36 x 19/32" LG.
21	(SEE TABLE BELOW)	1	TAILWAY
22	P97065	1	SPRING
24	PXA27409	2	O-RING (113) VITON, 9/16" ID x 3/4" OD
25	PXA26345	2	O-RING (112) VITON, 1/2" ID x 11/16" OD
26	P97036	1	END CAP
27	(SEE TABLE BELOW)	1	NOZZLE
28	P97063	3	DIAPHRAGM, TEFLON
29	P97058	1	MIDDLE BODY
30	P48976	1	SPRING
31	P97342	1	O-RING, VITON
32	P96973	1	UPPER BODY
33	AAA4325	1	DIAPHRAGM, VITON
34	PXA40040	1	O-RING (118) VITON, 7/8" ID x 1-1/16" OD

(21) TAILWAY	CODE
PXB 48962	B
PXC 48962	C
PXD 48962	D
PXE 48962	E
PXF 48962	F
PXG 48962	G
PXH 48962	H
PXJ 48962	J
PXS 48962	S

(27) NOZZLE	SIZE #
PXC 49042	70
PXD 49042	84
PXE 49042	99
PXF 49042	120
PXG 49042	140
PXH 49042	165
PXJ 49042	193
PXK 49042	242

WHEN ORDERING MATERIAL, ALWAYS SPECIFY MODEL AND SERIAL NUMBER OF APPARATUS.

AAA4307 3/4" ANTI-SYPHON INJECTOR - PARTS LIST

25.200.002.020B

ISSUE 5 4-05

S10K V-NOTCH CHLORINATOR

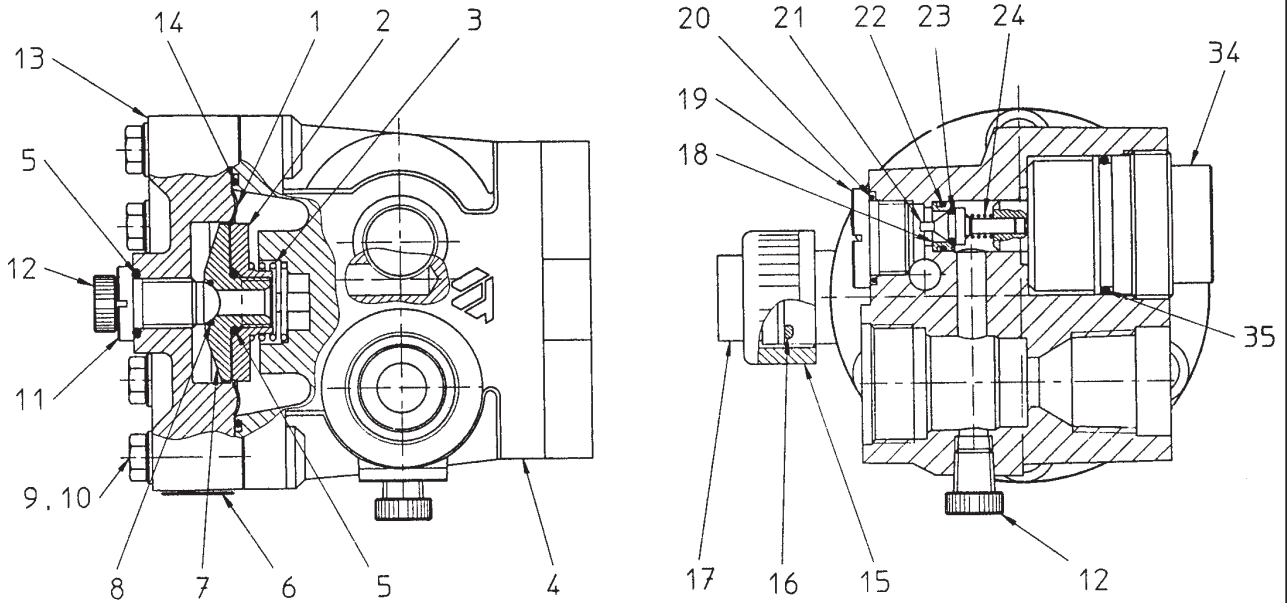

NOTE: FOR PARTS LIST, SEE DWG. 25.200.002.030B.

AAA4316 1" STANDARD INJECTOR - PARTS

25.200.002.030A

ISSUE 0 10-95

S10K V-NOTCH CHLORINATOR

KEY NO.	PART NO.	QTY.	DESCRIPTION
1	P97062	1	DIAPHRAGM
2	P97045	1	NUT
3	ANM4147	1	SPRING
4	P97042	1	LOWER BODY
5	PXA26784	2	O-RING (114) VITON, 5/8" ID x 13/16" OD
6	ADH4733	1	CAUTION LABEL
7	AAD2584	1	SEAT
8	P97342	1	O-RING (VITON) 11 MM
9	AAA1905	6	SCREW, MONEL
10	P97046	6	WASHER
11	P97048	1	VALVE STEM
12	P31295	2	PLUG, 1/4 NPT
13	P96971	1	UPPER BODY
14	P50524	1	O-RING (151) VITON, 3" ID x 3-3/16" OD
15	P100363	1	UNION NUT
16	PXA40575	1	O-RING (211) VITON, 13/16" ID x 1-1/16" OD
17	AMK421 8	1	ADAPTER, 1/2 NPT
18	P97040	1	SEAT, POPPET
19	P97050	1	PLUG
20	PXA39892	1	O-RING (119) VITON, 15/16" ID x 1-1/8" OD
21	P97032	1	POPPET
22	P97041	1	O-RING, SEAT
23	ANM3591	1	O-RING, VITON
24	P48655	1	SPRING, POPPET
34	P97049	1	GUIDE PLUG POP.
35	P 1 00448	1	O-RING, VITON

WHEN ORDERING MATERIAL, ALWAYS SPECIFY MODEL AND SERIAL NUMBER OF APPARATUS.

AAA4316 1" STANDARD INJECTOR - PARTS LIST

25.200.002.030B

ISSUE 1 8-08

S10K V-NOTCH CHLORINATOR

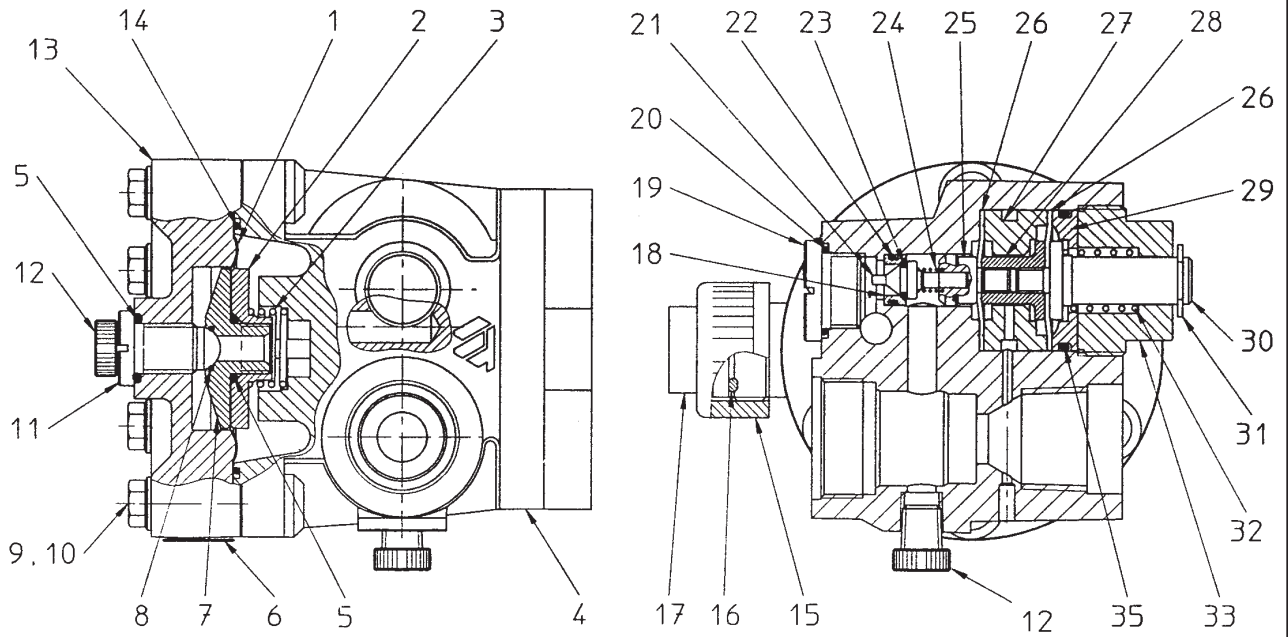

NOTE: FOR PARTS LIST, SEE DWG. 25.200.002.040B.

AAA4313 1" ANTI-SYPHON INJECTOR - PARTS

25.200.002.040A

ISSUE 0 10-95

S10K V-NOTCH CHLORINATOR

KEY NO.	PART NO.	QTY.	DESCRIPTION
1	P97062	1	DIAPHRAGM
2	P97045	1	NUT
3	ANM4147	1	SPRING
4	P96970	1	LOWER BODY
5	PXA26784	2	O-RING (114) VITON, 5/8" ID x 13/16" OD
6	ADH4733	1	CAUTION LABEL
7	AAD2584	1	SEAT
8	P97342	1	O-RING (VITON) 11 MM
9	AAA1905	6	SCREW, MONEL
10	P97046	6	WASHER
11	P97048	1	VALVE STEM
12	P31295	2	PLUG, 1/4 NPT
13	P96971	1	UPPER BODY
14	P50524	1	O-RING (151) VITON, 3" ID x 3-3/16" OD
15	P100363	1	UNION NUT
16	PXA40575	1	O-RING (211) VITON, 13/16" ID x 1-1/16" OD
17	AMK4218	1	ADAPTER, 1/2 NPT
18	P97040	1	SEAT, POPPET
19	P97050	1	PLUG
20	PXA39892	1	O-RING (119) VITON, 15/16" ID x 1-1/8" OD
21	P97032	1	POPPET
22	P97041	1	O-RING, SEAT
23	ANM3591	1	O-RING, VITON
24	P48655	1	SPRING, POPPET
25	P97054	1	GUIDE BUSHING
26	P97061	2	DIAPHRAGM
27	P97053	1	NUT, COUPLING
28	P97052	1	SPACER
29	P97055	1	CLAMPING WASHER
30	P97056	1	UNION
31	PXG95967	1	SNAP RING
32	P97064	1	SPRING
33	P97051	1	CLAMPING NUT
35	PI 00448	1	O-RING, VITON

WHEN ORDERING MATERIAL, ALWAYS SPECIFY MODEL AND SERIAL NUMBER OF APPARATUS.

AAA4313 1" ANTI-SYPHON INJECTOR - PARTS LIST

25.200.002.040B

ISSUE 2 8-08

S10K V-NOTCH CHLORINATOR

3/4" HOSE OR FLEXIBLE PIPE CONNECTION

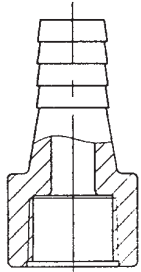

P47206
3/4" PIPE X
3/4" HOSE
ADAPTER

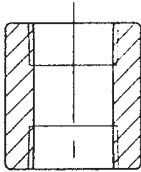

• P37599
3/4" PLASTIC PIPE
ADAPTER

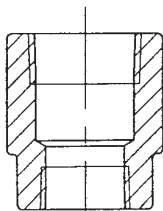

• P39771
3/4" X 1"
PLASTIC PIPE
ADAPTER

OR

OR

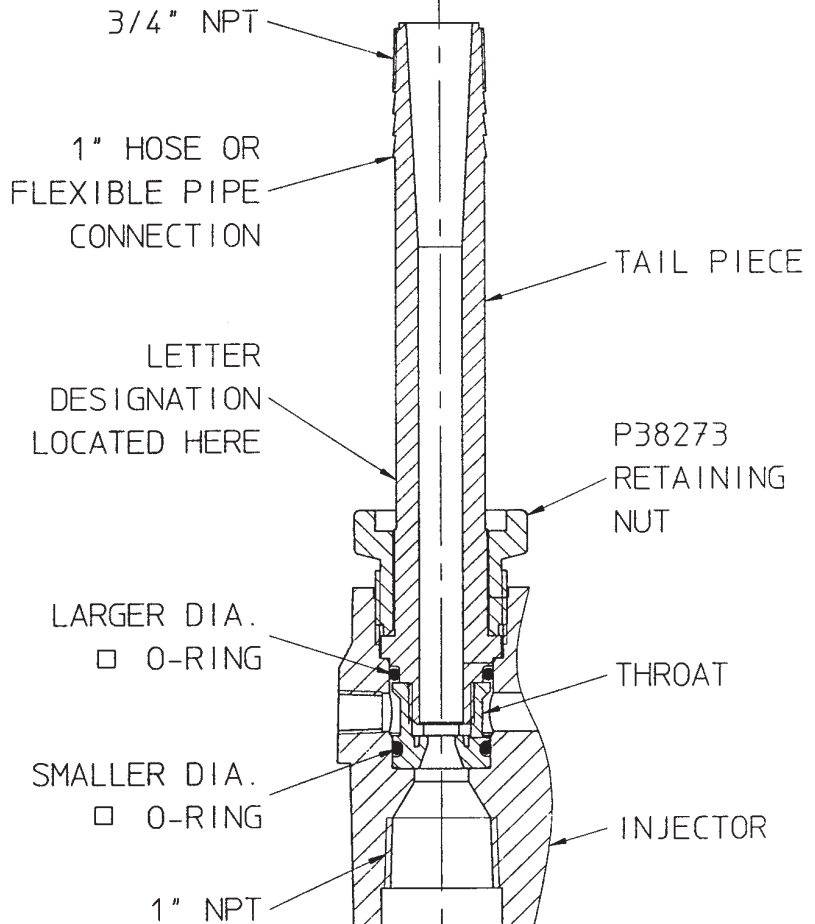

SIZE NUMBER
LOCATED HERE



- SOLUTION HOSE MAY BE CONNECTED DIRECTLY TO THE INJECTOR TAILWAY. IF RIGID PVC PIPE IS USED, A PIECE OF STRAIGHT PIPE AT LEAST EIGHT INCHES LONG SHOULD BE COUPLED TO THE END OF THE INJECTOR TAILWAY BEFORE ANY ELBOWS, TEES, OR SIMILAR FLOW RESTRICTIONS ARE USED. THIS IS TO PREVENT ANY FLOW DISTURBANCES THAT COULD AFFECT THE HYDRAULIC PERFORMANCE OF TAILWAY CONNECTIONS.

NOTE: SIZE NUMBER STAMPED ON THROAT. LETTER DESIGNATION STAMPED ON TAILPIECE. WHEN REORDERING O-RINGS MARKED □ SPECIFY U21275 FOR PAIR. NOT SOLD SEPARATELY.

PLASTIC 1" FIXED THROAT INJECTOR AND TAILWAY DETAILS - PARTS

25.200.003.010A

ISSUE 0 10-95

S10K V-NOTCH CHLORINATOR

THROAT		TAIL PIECE		3/4" HOSE OR FLEXIBLE PLASTIC PIPE	3/4" RIGID PIPE	1" HOSE OR FLEXIBLE PLASTIC PIPE	1" RIGID PIPE
SIZE	PART NO.	LETTER DESIG.	PART NO.				
70	PXC50094	B	PXB50093	X	X	O	O
		C	PXC50093	X	X	O	O
99	PXE50094	C	PXC50093	X	X	O	O
		D	PXD50093	X	X	X	O
		E	PXE50093	X	X	X	O
120	PXF50094	D	PXD50093	X	X	X	X
		E	PXE50093	X	X	X	X
		F	PXF50093	X	X	X	X
140	PXG50094	E	PXE50093	X	X	X	X
		F	PXF50093	X	X	X	X
		G	PXG50093	X	X	X	X
165	PXH50094	F	PXF50093	X	X	X	X
		G	PXG50093	X	X	X	X
		H	PXH50093	X	X	X	X
193	PXJ50094	G	PXG50093	-	X	X	X
		H	PXH50093	-	-	X	X
		I	PXJ50093	-	-	X	X
242	P XK50094	H	PXH50093	-	-	X	X
		I	PXJ50093	-	-	X	X
		K	PXK50093	-	-	X	X
312	PXL50094	K	PXK50093	-	-	X	X
		L	PXL50093	-	-	X	X

ASSEMBLY NOTES: ASSEMBLE THROAT, TWO O-RINGS, AND TAILPIECE AS SHOWN, BEFORE INSERTING IN INJECTOR BODY.

ORDERING INFORMATION:

- X** STANDARD COMBINATION WHEN HYDRAULIC CONDITIONS PERMIT.
 - O** NON-STANDARD COMBINATION, MAY BE USED IF REQUIRED.
- IF NO SYMBOL IS INDICATED, COMBINATION CANNOT BE USED.

WHEN ORDERING MATERIAL, ALWAYS SPECIFY MODEL AND SERIAL NUMBER OF APPARATUS.

PLASTIC 1" FIXED THROAT INJECTOR AND TAILWAY DETAILS - PARTS LIST

25.200.003.010B

ISSUE 0 10-95

S10K V-NOTCH CHLORINATOR

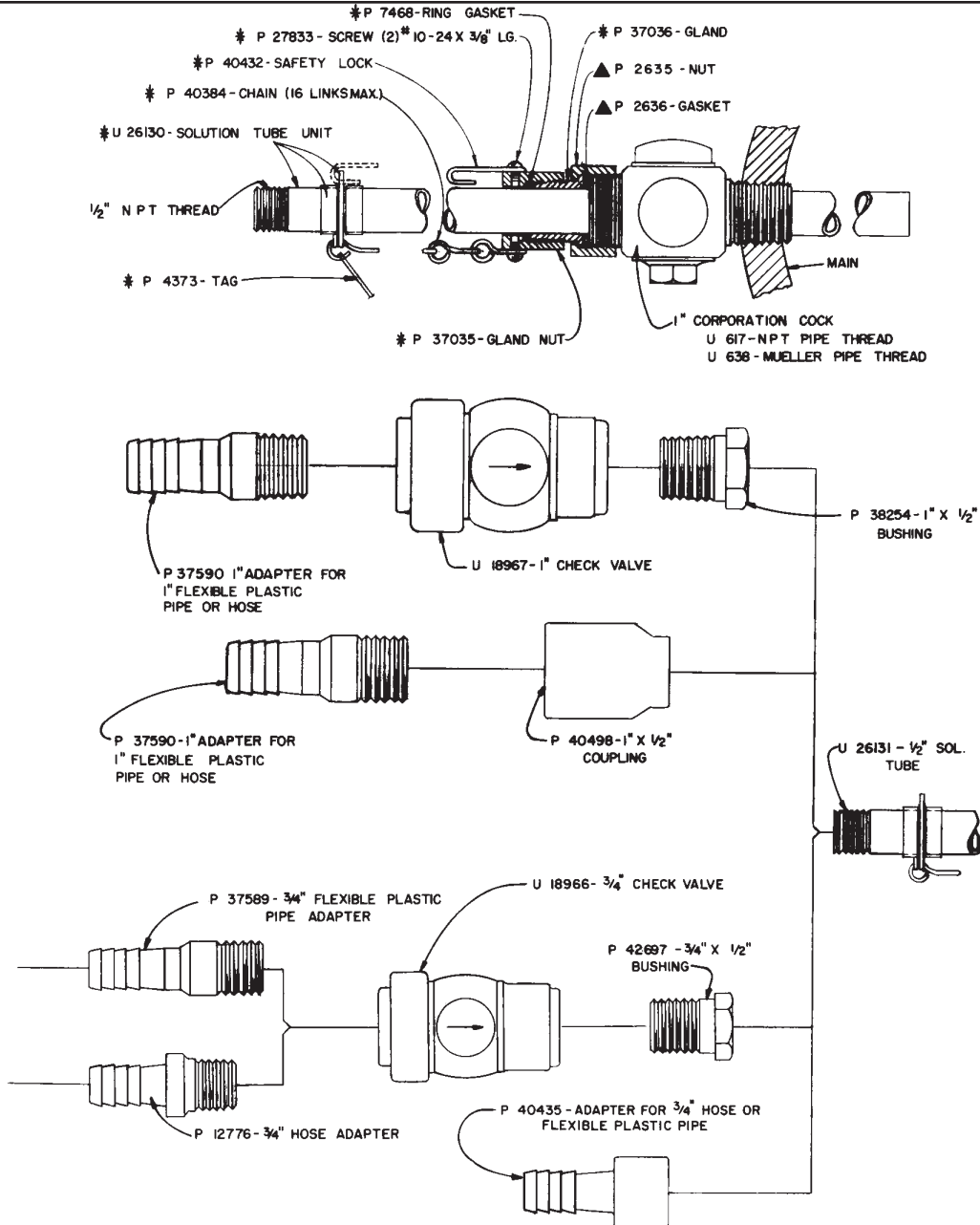

NOTE: * PART OF SOLUTION TUBE U26131. ▲ PART OF CORPORATION COCK U617 OR U638.

WARNING: TO AVOID POSSIBLE SEVERE PERSONAL INJURY OR DAMAGE TO EQUIPMENT, DO NOT EXCEED WORKING PRESSURE OF HOSE OR FLEXIBLE PLASTIC PIPE. NEVER EXCEED 125 PSI AT 70° F. USE RIGID PIPE BETWEEN DISCHARGE AND MAIN CONNECTIONS WHEN PUMPING HAZARDOUS CHEMICALS.

CAUTION: FOR PROPER DISPERSION OF SOLUTION, THE END OF THE TUBE MUST EXTEND INTO THE MAIN, APPROXIMATELY 1/2 TO 1/3 THE DIAMETER OF THE MAIN. CUT OFF THE TUBE IF TOO LONG AND SHORTEN CHAIN AN EQUAL AMOUNT.

WHEN ORDERING MATERIAL, ALWAYS SPECIFY MODEL AND SERIAL NUMBER OF APPARATUS.

PLASTIC MAIN CONNECTION - PARTS
 For 3/4" Or 1" Solution Lines With 1" Corporation Cock

50.845.06.011

ISSUE 14 2-93

S10K V-NOTCH CHLORINATOR

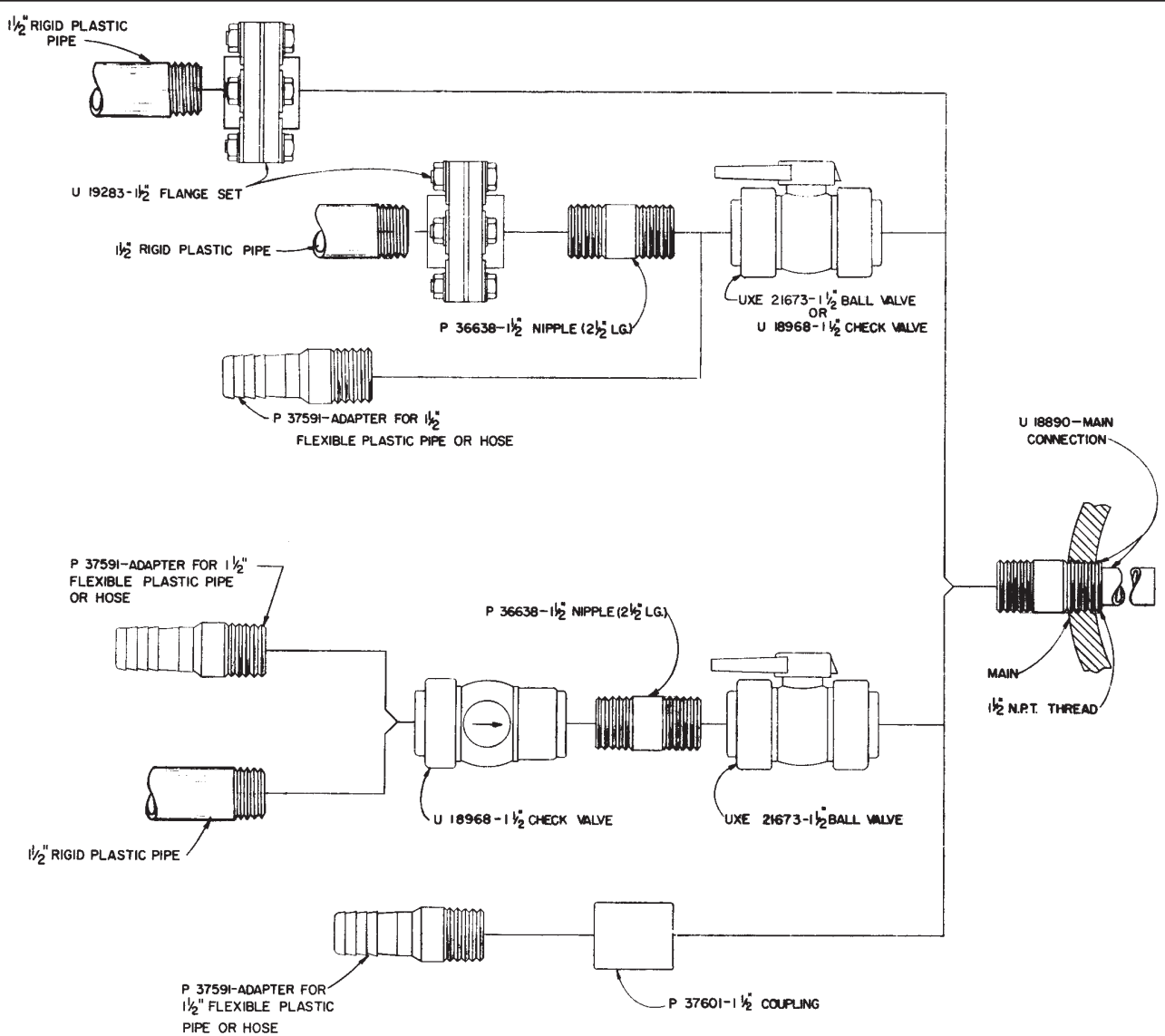

WARNING: TO AVOID POSSIBLE SEVERE PERSONAL INJURY OR DAMAGE TO EQUIPMENT, DO NOT EXCEED WORKING PRESSURE OF HOSE OR FLEXIBLE PLASTIC PIPE. NEVER EXCEED 100 PSI AT 70° F. USE RIGID PIPE BETWEEN DISCHARGE AND MAIN CONNECTIONS WHEN PUMPING HAZARDOUS CHEMICALS.

CAUTION: FOR PROPER DISPERSION OF SOLUTION, THE END OF THE TUBE MUST EXTEND INTO THE MAIN, APPROXIMATELY 1/2 TO 1/3 THE DIAMETER OF THE MAIN. CUT OFF THE TUBE IF TOO LONG.

WHEN ORDERING MATERIAL, ALWAYS SPECIFY MODEL AND SERIAL NUMBER OF APPARATUS.

MAIN CONNECTION - PARTS
For 1-1/2" Solution Line

50.845.006.021

ISSUE 12 9-92

S10K V-NOTCH CHLORINATOR

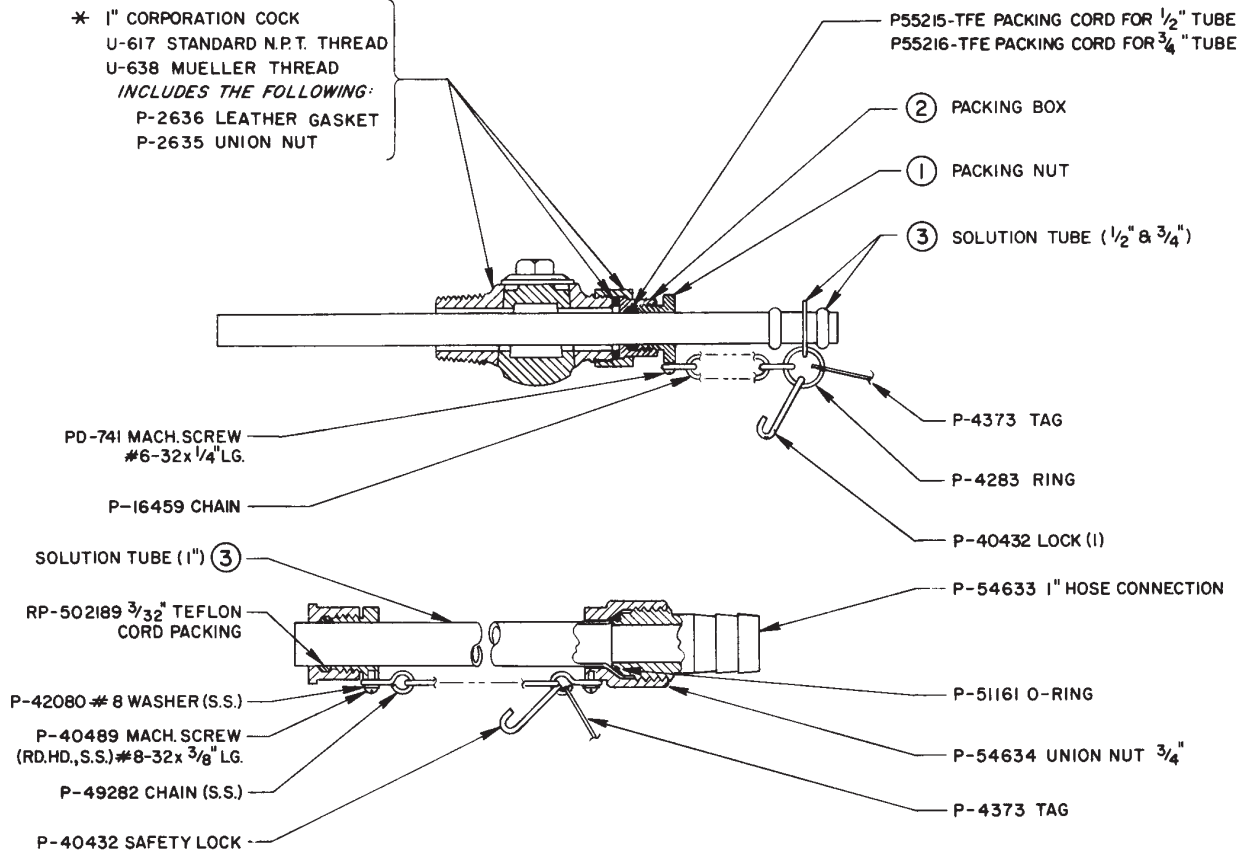

SOLUTION TUBE SIZE	1	2	3
1/2"	P-1129	P-1128	U-2476
3/4"	P-1274	P-1275	U-2475
1"	P-1274	P-1275	P-54632

COMPLETE SOLUTION TUBES
* U-1267 - 1/2"
* U-1269 - 3/4"
* U-26488 - 1"

NOTE: * DOES NOT INCLUDE CORPORATION COCK. ORDER SEPARATELY, SPECIFYING PIPE THREAD.

WHEN ORDERING MATERIAL, ALWAYS SPECIFY MODEL AND SERIAL NUMBER OF APPARATUS.

MAIN CONNECTION - PARTS
 For Hose

50.845.02.011

ISSUE 6 2-82



S10K V-NOTCH CHLORINATOR

SECTION 6

S10K V-NOTCH CHLORINATOR

SECTION 6 - PREVENTIVE MAINTENANCE KITS AND SPARE PARTS LIST

S10K V-NOTCH GAS FEEDER

<u>DESCRIPTION</u>	<u>PART NO.</u>
Preventive Maintenance Kit (Control Unit) 3" Rotameter	AAA 1349
Preventive Maintenance Kit (Control Unit) 5" Rotameter	AAA 1343
Preventive Maintenance Kit (3/4" Injector)	APQ 4389
Preventive Maintenance Kit (1" Injector)	AJE 4406
Preventive Maintenance Kit (3/4" Anti-Syphon Injector)	APP 4379
Preventive Maintenance Kit (1" Anti-Syphon Injector)	AJA 4403

ADDITIONAL SPARE PARTS

<u>QTY</u>	<u>DESCRIPTION</u>	<u>PART NO.</u>
1	4oz. Bottle Ammonia Solution	U409
1	Halocarbon Grease	U27546

**CHLORINE HANDLING
MANUAL**
(Cl₂)

BOOK NO. WT.025.000.001.UA.IM.0614

REGIONAL OFFICES

INSTALLATION, OPERATION, MAINTENANCE, AND SERVICE INFORMATION

Direct any questions concerning this equipment that are not answered in the instruction book to the Reseller from whom the equipment was purchased. If the equipment was purchased directly from Evoqua Water Technologies, Colorado Springs, CO contact the office indicated below.

UNITED STATES

725 Wooten Road
Colorado Springs, CO 80915
TEL: (800) 524-6324

CANADA

If the equipment was purchased directly from Evoqua Water Technologies, Canada, contact the nearest office indicated below.

ONTARIO

Evoqua Water Technologies Ltd.
2045 Drew Road
Mississauga, Ontario
L5S 1S4
(905) 944-2800

QUEBEC

Evoqua Technologies des Eaux Itée
505 Levy Street
St. Laurent, Quebec
H4R 2N9
(450) 582-4266

CHLORINE HANDLING MANUAL

CHLORINE HANDLING MANUAL

WARNING:

CHLORINE IS A HAZARDOUS CHEMICAL THAT CAN CAUSE INJURY AND DEATH IF NOT HANDLED PROPERLY. THIS MANUAL CONTAINS ONLY GENERAL INFORMATION ON THE PHYSICAL PROPERTIES, STORAGE, AND HANDLING OF CHLORINE. IT IS NOT INTENDED TO REPLACE OR LIMIT SAFETY PROCEDURES IN YOUR FACILITY.

SAFETY PROCEDURES IN AN INDUSTRIAL SETTING MUST BE DESIGNED IN ACCORDANCE WITH ALL GOVERNMENTAL REGULATIONS AND NATIONAL SAFETY CODES, AFTER GIVING FULL CONSIDERATION TO THE SPECIFIC NEEDS OF THE INDUSTRIAL FACILITY INVOLVED.

EVOQUA WATER TECHNOLOGIES CANNOT ANTICIPATE THE SPECIFIC SAFETY PROCEDURES REQUIRED AT EVERY INDUSTRIAL FACILITY. ACCORDINGLY, EVOQUA WATER TECHNOLOGIES DOES NOT GUARANTEE THAT SAFETY PROCEDURES DESIGNED IN ACCORDANCE WITH THIS MANUAL WILL COMPLETELY ELIMINATE HAZARDS AND THUS ASSUMES NO LIABILITY FOR ACCIDENTS THAT MAY OCCUR IN YOUR FACILITY.

READ THIS ENTIRE MANUAL AND BE FULLY FAMILIAR WITH YOUR EQUIPMENT AND YOUR ENTIRE INDUSTRIAL SYSTEM SO THAT THE SAFETY PROCEDURES YOU ESTABLISH WILL MEET THE NEEDS OF THE EMPLOYEES IN YOUR FACILITY. READING ONLY PART OF THE MANUAL WILL NOT HELP YOU ANALYZE THE NEEDS OF YOUR FACILITY. CONTACT YOUR CHLORINE SUPPLIER, THE CHLORINE INSTITUTE, INC., OR SIMILAR ORGANIZATION TO OBTAIN A MATERIAL SAFETY DATA SHEET (MSDS) AND MORE DETAILED INFORMATION ON CHLORINE. INFORMATION IS AVAILABLE FROM: THE CHLORINE INSTITUTE, INC., 1300 WILSON BOULEVARD, ARLINGTON, VA 22209.

PLEASE NOTE THE PUBLICATION DATE AND POSSIBLE OBSOLESCENCE OF THIS MATERIAL AS A RESULT OF SCIENTIFIC AND MEDICAL DEVELOPMENTS AFTER THE DATE OF PUBLICATION. THIS APPLIES TO ALL MATERIALS YOU REVIEW IN THE COURSE OF DEVELOPING SAFETY PROCEDURES FOR USE AT YOUR FACILITY.

Table Of Contents

	PARA. NO.
Introduction.....	1
Technical Data and Characteristics of Chlorine	2
Supply Containers.....	3
Maximum Gas Withdrawal Rates	3.1
Manifolding for Gas Withdrawal.....	3.1.1
Maximum Liquid Withdrawal Rate	3.2
Manifolding for Liquid Withdrawal.....	3.2.1
Container Valves.....	3.3
Pressure Relief Devices.....	3.4
Storage of Containers	3.5

Table Of Contents (Cont'd)

Handling Containers	3.6
Using Containers.....	3.7
Piping.....	4
Piping Materials and Joints.....	4.1
Gas Piping Installation Requirements.....	4.2
Liquid Piping Installation Requirements	4.3
Pressure Relief and Vent Piping Requirements.....	4.4
Valves.....	4.5
Pressure Gauges and Switches	4.6
Pressure Relief Devices.....	4.7
Preparation for Use	4.8
Personnel Safety.....	5
General.....	5.1
Health Hazards	5.2
Safety Precautions	5.3
Emergency Action Plans	5.4
Chemical Disposal Facilities	5.5

1 INTRODUCTION

This manual discusses the characteristics, storage and handling of chlorine used with Evoqua Water Technologies equipment. Chlorine is used with Evoqua Water Technologies equipment primarily as a disinfectant in water or wastewater treatment.

WARNING:

CHLORINE IS HAZARDOUS. TO AVOID SEVERE PERSONAL INJURY OR DEATH BY SUFFOCATION, READ THIS MANUAL AND THE CHLORINE SUPPLIER'S PRECAUTIONS BEFORE HANDLING OR CONNECTING CHLORINE TO EVOQUA WATER TECHNOLOGIES EQUIPMENT.

WHEN WORKING WITH CHLORINE:

ENSURE THAT APPROVED, SELF-CONTAINED BREATHING APPARATUS IS ALWAYS AVAILABLE AND PERSONNEL ARE PROPERLY TRAINED IN ITS USE.

ENSURE THAT SAFETY EQUIPMENT, SUCH AS VENTILATION FANS AND BREATHING APPARATUS, IS INSPECTED AND MAINTAINED IN ACCORDANCE WITH THE MANUFACTURER'S INSTRUCTIONS.

ENSURE THAT APPROPRIATE PLACARDS AND WARNING SIGNS ARE IN PLACE AND PROMINENTLY DISPLAYED IN THE AREAS WHERE THE GAS IS STORED.

IN CASES OF ACCIDENT:

USE SAFETY EQUIPMENT TO PROTECT THE RESCUER AND MOVE VICTIM TO FRESH AIR. IF BREATHING HAS STOPPED, START ARTIFICIAL RESPIRATION IMMEDIATELY.

IF HEART HAS STOPPED, START CPR (CARDIOPULMONARY RESUSCITATION) IMMEDIATELY. IN ALL CASES, OBTAIN MEDICAL ATTENTION AS SOON AS POSSIBLE.

TO AVOID ACCIDENTAL GAS RELEASE:

KNOWLEDGEABLE DESIGN PERSONNEL SHOULD OVERSEE AND APPROVE EQUIPMENT INSTALLATION AND SUITABILITY OF THE SYSTEM FOR WHICH IT IS INTENDED. QUALIFIED PERSONNEL SHOULD PERFORM PERIODIC INSPECTION TO ENSURE PROPER MAINTENANCE OF THE EQUIPMENT.

MONITOR SAFETY PROGRAMS AND CONDUCT PERIODIC TRAINING PROGRAMS, ESPECIALLY ON EMERGENCY SITUATIONS. SAFETY PROGRAMS ARE AVAILABLE FROM YOUR GAS SUPPLIER.

LOCAL LAWS:

UNDER NO CIRCUMSTANCES SHOULD THE INFORMATION IN THIS BOOK BE CONSTRUED AS SUBSTITUTING FOR OR SUPERSEDING ANY LOCAL, STATE, OR FEDERAL LAWS AND REGULATIONS CONCERNING THE STORAGE, HANDLING, OR USE OF CHLORINE.

CHLORINE HANDLING MANUAL

2 TECHNICAL DATA AND CHARACTERISTICS OF CHLORINE

The following general information on chlorine may be useful in planning a chlorinator installation; however, a specific application may require more information than that included here. For further information, consult your chlorine supplier, the Chlorine Institute, Inc., or similar organization.

Chlorine in commerce is a liquefied gas under pressure. It is a clear, amber-colored liquid. The gas has a greenish-yellow color and a strong, pungent odor. It is an irritant to the skin and respiratory system. In the moisture-free state at ordinary temperatures, it is relatively non-corrosive. In the presence of moisture, however, it is highly corrosive. Accordingly, every precaution should be taken to avoid leaks, to stop them promptly if they occur, and to keep moisture out of valves, tubing, etc., not specifically designed to handle moist chlorine. Among the important physical properties of chlorine are:

Specific Gravity, Dry Gas
2.48 at 32° F and 1 atm referred to air.

Specific Gravity, Liquid
1.47 at 32° F and 53 . 5 psia.

Liquid to Gas volume Ratio
1:456.5 at 32° F and 1 atm.

Latent heat of Vaporization
123.9 Btu per lb at boiling point, -29.2° F.

Specific Volume, Dry Gas
1 lb = 4.99 of at 32° F and 1 atm.

Specific Volume, Liquid
1 lb = 0.0109 cf at 32° F and 53.5 psia.

Weight, Dry Gas
1 cf = 0.2006 lb at 32° F and 1 atm.

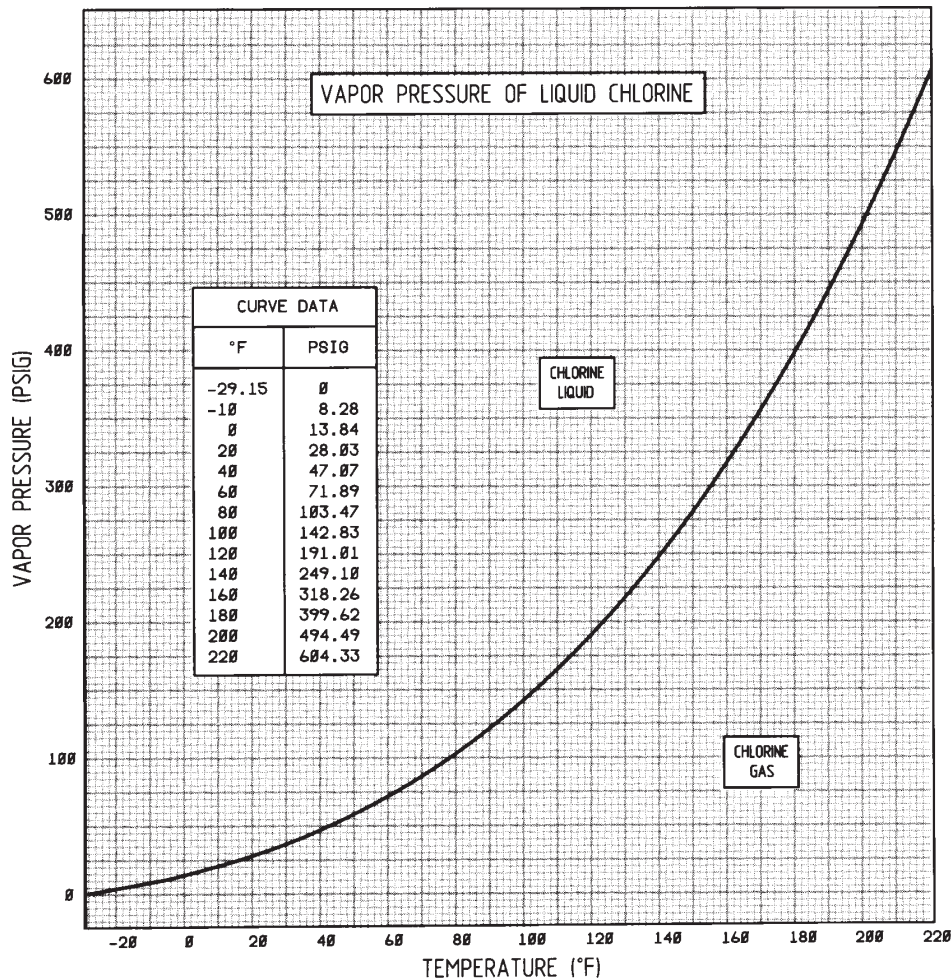

Figure 1 – Chlorine Pressure vs Temperature

SOURCE: THE CHLORINE MANUAL, FIFTH EDITION, PUBLISHED BY THE CHLORINE INSTITUTE, INC.

CHLORINE HANDLING MANUAL

Weight, Liquid

1 cf = 91.56 lb at 32° F.

Solubility in Water*

6.93 lbs./100 gals at 60° F and 1 atm.

Pressure vs Temperature

See Figure 1

***NOTE: Theoretical values shown. Actual solubility in water based on chlorinator performance has proven to be 3500 ppm or 2.92 lbs/100 gals maximum.**

Chlorine is an oxidizing agent and will support combustion but is not explosive or flammable. Many organic chemicals will react with chlorine, some violently. Steel will ignite spontaneously in the presence of chlorine at 483° F.

3 SUPPLY CONTAINERS

Table 1 gives details on the supply containers most commonly used with Evoqua Water Technologies equipment.

Some large installations that would normally use single unit tank cars but are not serviced by railroad facilities use tank motor vehicles (tank trailers) which usually range in capacity from 15 to 22 tons.

All supply containers must conform to appropriate Department of Transportation (DOT) and Canadian Transport Commission (CTC) regulations. It is the responsibility of the supply container manufacturer and the chlorine supplier to meet these requirements.

3.1 RATES

In general, using a remote vacuum type chlorinator, the maximum sustained gas withdrawal rate at which chlorine may be taken from a 100 or 150 pound cylinder is one pound per day per degree Fahrenheit (1.0 lb/24 hrs/°F). The corresponding rate for ton containers is about 8.0 lbs/24 hrs/°F. At an assumed liquid temperature of 70° F (and using a remote vacuum type chlorinator) the above figures translate into 70 lbs/24 hrs for cylinders and 560 lbs/24 hrs for ton containers. For a direct feed cylinder pressure operated chlorinator these rates become 42 and 336 lbs/24 hrs respectively. These rates can be increased substantially for brief periods. Do not place containers in a water bath or apply direct heat in order to permit higher withdrawal rates.

It is not practical to withdraw chlorine as a gas from tank cars (or tank trailers).

3.1.1 MANIFOLDING FOR GAS WITHDRAWAL

When higher gas withdrawal rates are required, cylinders or the gas valves (upper) of ton containers may be manifolded. A typical arrangement for manifolding cylinders is shown in Figure 2.

If cylinders or ton containers are manifolded, it is essential that all supply containers be at the same temperature to prevent the transfer of liquid chlorine from a warmer container to a cooler container, possibly resulting in a container becoming overfilled through reliquefaction of chlorine in the cooler container.

TABLE 1 - CHLORINE CONTAINER INFORMATION

TYPE OF CONTAINER	NET WEIGHT	TARE WEIGHT	GROSS WEIGHT	OUTSIDE DIAMETER	LENGTH
CYLINDERS	100 lb	63 - 115 lb	163 - 215 lb	8-1/4" - 10-3/4"	3'3-1/2" - 4'11"
	150 lb	85 - 140 lb	235 - 290 lb	10-1/4" - 10-3/4"	4'5" - 4'8"
TON CONTAINER	2000 lb	1300 - 1650 lb	330 - 3650 lb	2'6"	6'7-3/4" - 6'10-1/2"
SINGLE UNIT TANK CARS	16 tons	-	-	10'5" - 12'0"	32'2" - 33'3"
	30 tons	-	-	12'4-1/2" - 13'7"	33'10" - 35'11-1/2"
	55 tons	-	-	14'3" - 15'1"	29'9" - 43'0"
	85 tons	-	-	14'11" - 15'1"	43'7" - 50'0"
	90 tons	-	-	14'11" - 15'1"	45'8" - 47'2"

Dimensional data from Chlorine Manual, Fifth Edition, published by the Chlorine Institute, Inc.

(1) The 150 lb cylinder is generally most readily available. Either the 100 lb or 150 lb size may be shipped full or empty via truck or rail in small lots or in full truck or carloads.

(2) Chlorine from Single Unit Tank Cars is generally unloaded directly from the car as needed in order to eliminate the necessity of storage tanks. Cars are leased to the consumer during this period and are consigned to private sidings only. Two parallel tracks are recommended to facilitate the handling of cars and to permit continuous operation without shut-down periods while cars are being switched.

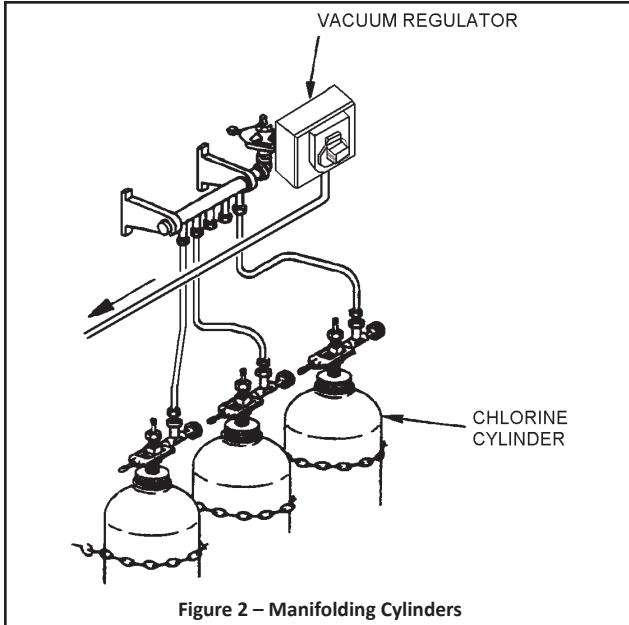

Figure 2 – Manifolding Cylinders

3.2 MAXIMUM LIQUID WITHDRAWAL RATE

The generally accepted alternate to manifolding ton containers is to withdraw liquid chlorine from the lower valve and use an evaporator. By this means, a ton container can be emptied in approximately five hours, which is equivalent to 9600 lbs/24 hrs.

Liquid can be withdrawn from tank cars at up to nearly 8,000 pounds per hour, or 192,000 pounds per 24 hours.

3.2.1 MANIFOLDING FOR LIQUID WITHDRAWAL

WARNING: IN ACCORDANCE WITH CHLORINE INSTITUTE RECOMMENDATIONS, DO NOT MANIFOLD TON CONTAINERS FOR SIMULTANEOUS LIQUID CHLORINE WITHDRAWAL. THIS MANIFOLDING CAN CAUSE OVER-PRESSURIZATION AND RUPTURE.

3.3 CONTAINER VALVES

Standard cylinder and ton container valves are identical in design, except that the cylinder valve includes a pressure relief device. Cylinder valves are shown in Figure 3 and ton container valves in Figure 4.

See Figure 5 for captive yoke type auxiliary container valves (valve connection style #820, recognized by the Compressed Gas Association as the only acceptable means of connecting to container valves). The external threads on the container valve are used only for securing the protective cap.

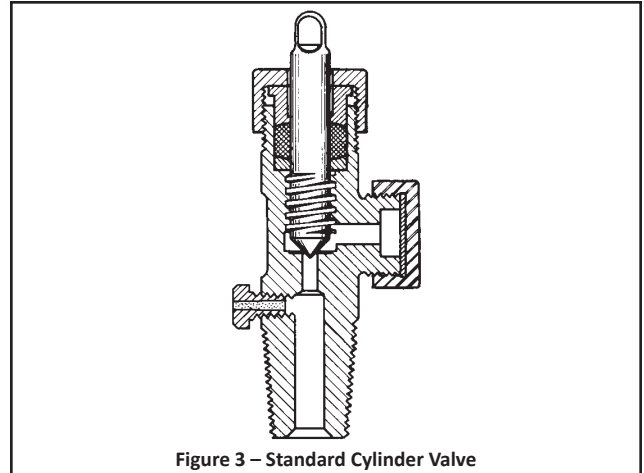

Figure 3 – Standard Cylinder Valve

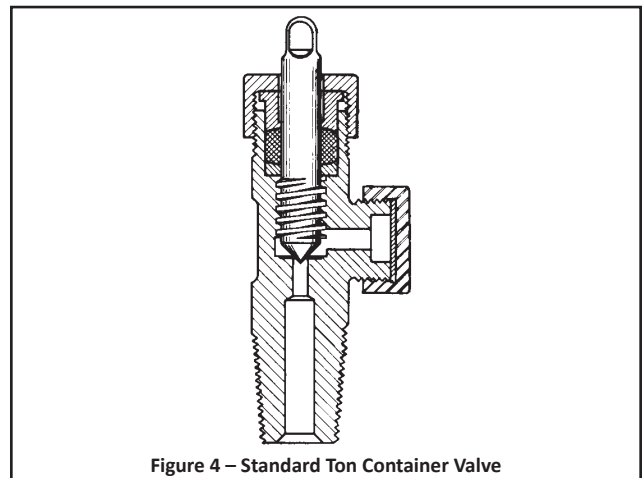

Figure 4 – Standard Ton Container Valve

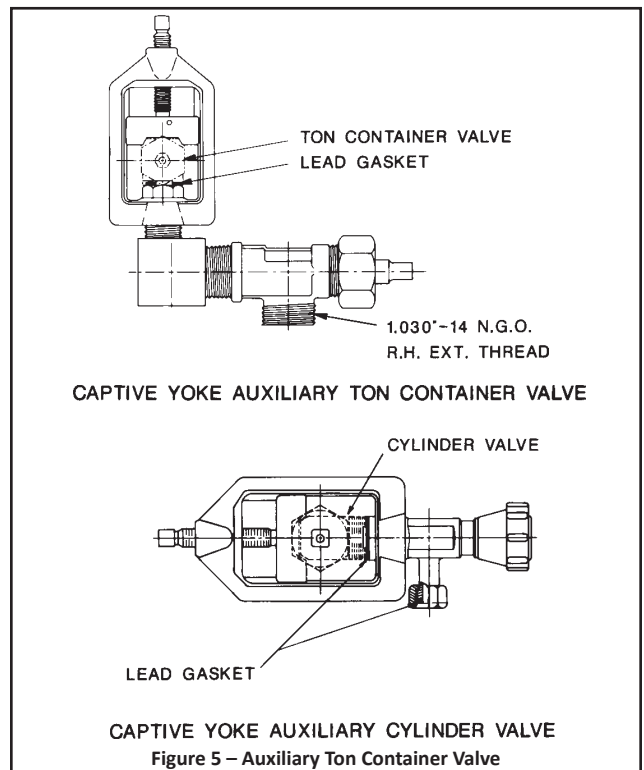

Figure 5 – Auxiliary Ton Container Valve

Cylinders are equipped with one valve that is normally used for gas withdrawal. Ton containers are equipped with two valves, as shown in Figure 6.

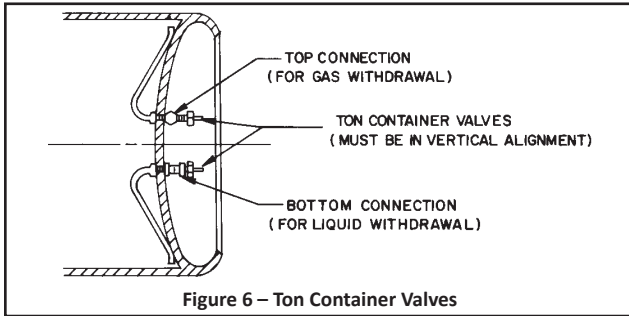

Figure 6 – Ton Container Valves

The upper valve is used for gas withdrawal and the lower valve for liquid withdrawal. Tank cars are equipped with four standard angle valves, as shown in Figure 7.

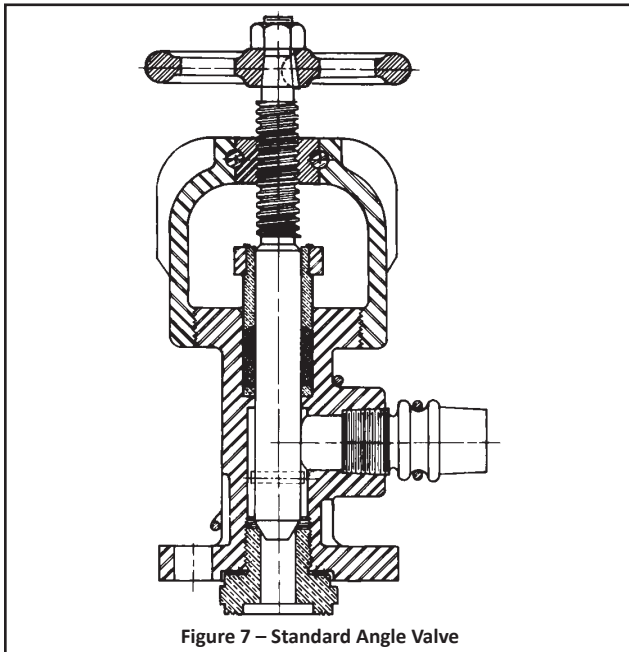

Figure 7 – Standard Angle Valve

Outlet is one-inch female ANSI Standard taper pipe thread. The liquid withdrawal valves are located on the longitudinal center line of the tank car. The valves on the transverse center line are connected to the vapor space and are used to obtain chlorine gas under pressure for testing the piping or for air padding the tank car.

3.4 PRESSURE RELIEF DEVICES

All chlorine supply containers are equipped with some type of device for relief of pressure. Cylinder valves have a fusible metal plug screwed into the body of the valve, as shown in Figure 3. The fusible metal melts when the temperature

increases to 158-165° F to relieve pressure and prevent rupture of the cylinder.

Ton containers are equipped with six fusible metal plugs (see Figure 8), three of which are in each end, spaced 120 degrees apart.

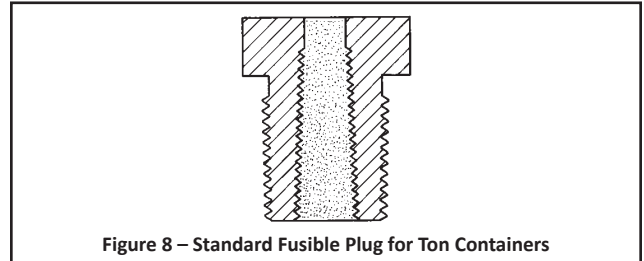

Figure 8 – Standard Fusible Plug for Ton Containers

Tank cars have an excess-flow valve (see Figure 9) located under each liquid valve. While this valve may close during a catastrophic pipe line failure, its main function is to close automatically if the angle valve is broken off in transit. Tank cars also have a pressure relief device (see Figure 10) located in the center of the manway. The relief level varies with the type of car or tank.

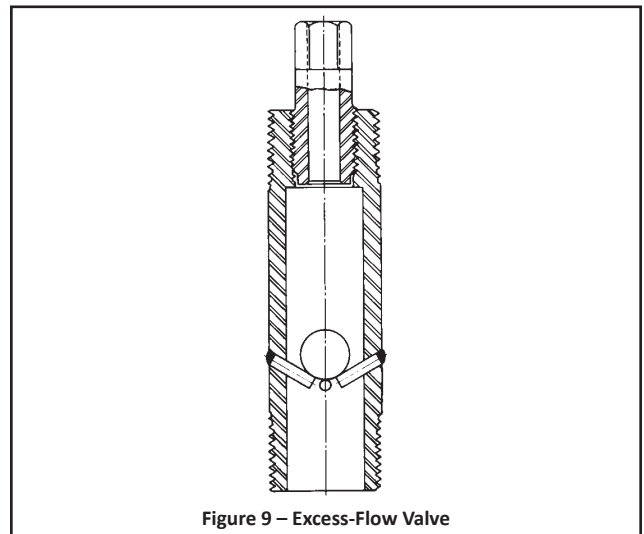

Figure 9 – Excess-Flow Valve

3.5 STORAGE OF CONTAINERS

Store chlorine containers of any type under cover and in cool, well ventilated locations protected from fire hazards and adequately protected from extreme weather conditions. During the summer months, full containers should be shielded from the direct rays of the sun, otherwise a dangerous build-up of pressure might result (see Figure 1 and Paragraph 3.3). If stored out of doors, keep containers in fenced-off areas for protection. Avoid storage in subsurface areas because chlorine is heavier than air and will not readily rise from

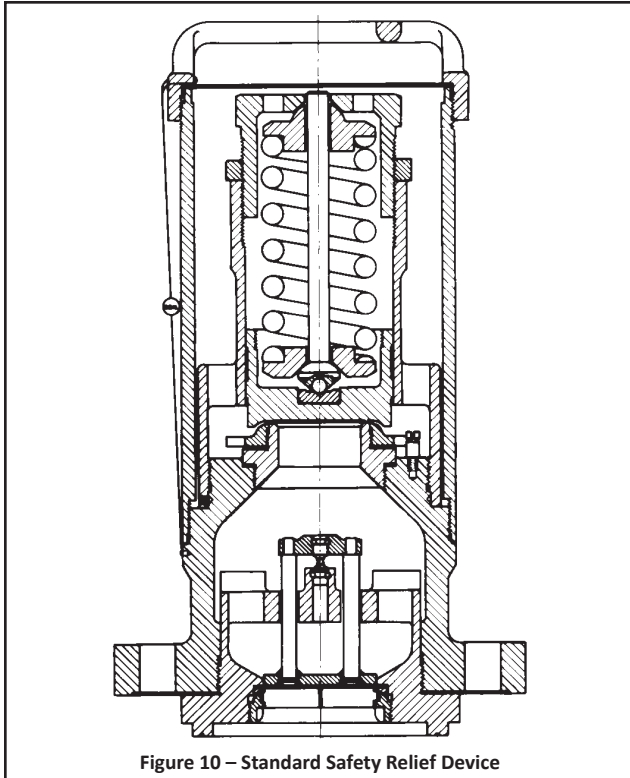

Figure 10 – Standard Safety Relief Device

subsurface locations should leaks occur. Do not store or use chlorine containers near other chemicals or gases.

WARNING: STORE CYLINDERS IN AN UPRIGHT POSITION. TO AVOID SEVERE PERSONAL INJURY OR EQUIPMENT DAMAGE, SUPPLY CYLINDERS MUST BE SECURED IN SUCH A MANNER (E.G., CHAIN) AS TO PREVENT THEIR BEING KNOCKED OVER. TON CONTAINERS MUST BE SECURED IN SUCH A MANNER (E.G., CROCKS) TO PREVENT THEIR ROLLING OUT OF PLACE.

Do not remove the protective cap or hood from cylinders or ton containers until they are ready to be put in actual use. Do not store containers in a heavily traveled area where physical contact damage could occur.

It is essential that areas used to house chlorine containers or equipment be continuously monitored for the presence of chlorine in the air. This may be a requirement of applicable laws and/or regulations.

When containers are moved from a storage area to an area where they will be used, allow sufficient time to stabilize the temperature, and therefore the pressure, of the container and the chlorine before it is used.

The chlorine inventory depends to a large extent on local availability. Consult with chlorine suppliers in the area; review appropriate fire code requirements concerning storage of oxidizing materials and other applicable laws and regulations.

When planning space for stored containers, sufficient space must be allowed for empty containers. The best way to determine the amount of chlorine remaining in a container is to weigh the container continuously on a scale. This also makes it possible to record the amount of chlorine used. Portable or dormant scales in beam, dial, or digital types and with varying platform sizes are available.

WARNING: ALWAYS REMOVE WHEELS AND AXLES OF PORTABLE SCALES SO THAT THE SCALE CANNOT MOVE WHEN CYLINDERS ARE ON THE PLATFORM.

Preferably, scales for cylinders should be installed with their platform flush with the floor to eliminate the necessity of lifting the cylinders. Some low profile scales such as the Wallace & Tiernan® Cylinder Scale are low enough that cylinders can be placed on the scale without lifting. Others are installed with ramps. If scales are pit mounted, a trapped drain should be provided.

Scales for ton containers are usually installed above the floor, since ton containers are usually handled by overhead conveyor. Many of these scales do not have platforms since the ton containers are usually supported by cradles or trunnions.

Special high-capacity scales are provided at some installations using tank cars. These scales are usually pit mounted below the railroad siding with the dial or digital unit housed above ground beside the track.

Some of the dial or digital scales are equipped with loss-of-weight recording systems providing a permanent record of chlorine usage.

3.6 HANDLING CONTAINERS

Always handle chlorine containers with utmost care. To prevent injury or damage, do not drop chlorine containers and do not permit containers to strike each other or other objects. To prevent damage to the valve, valve protecting caps or hoods must always be in place when containers are moved.

Handle cylinders with a simple two-wheel hand truck of the barrel pattern. Hand trucks should be well balanced and equipped with chains or clamps to prevent the cylinders from falling off the truck.

WARNING: NEVER LIFT CYLINDERS BY THE VALVE PROTECTING HOOD. THE HOOD MAY SEPARATE FROM THE CYLINDER, CAUSING THE CYLINDER TO FALL.

Never lift cylinders by sling or magnetic devices. If lifting is necessary, use a specially designed cradle. Contact your chlorine supplier for recommendations or information.

When moving ton containers, due consideration must be given to the fact that the liquid in the container represents a live load in addition to the dead load of the container and the liquid. The most accepted way of moving ton containers is by overhead conveyor and lifting beam (see Figure 11).

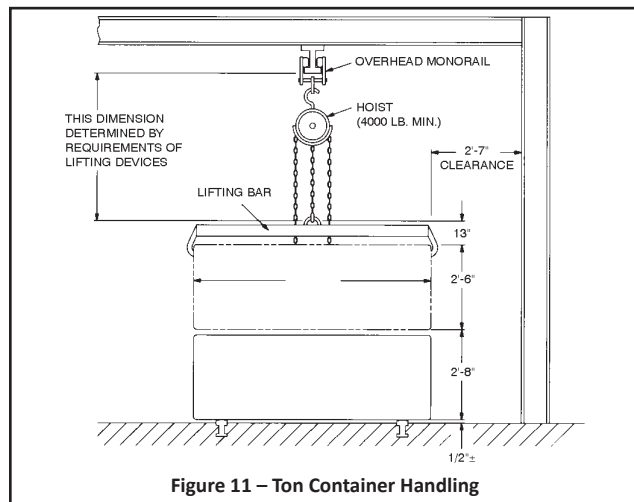

Figure 11 – Ton Container Handling

Rails or roller conveyors have also been used. Fork lift trucks, in addition to having adequate capacity, must have the containers restrained and be sufficiently stable to prevent tipping.

3.7 USING CONTAINERS

If containers have been stored in an area other than that in which they will be used, they should be allowed to stabilize at the new temperature before being used. Containers should always be used in the order in which they are received to avoid unnecessarily long storage and possible difficulty with valves that have not been opened or closed for too long a period.

WARNING: CYLINDERS ARE NORMALLY USED IN AN UPRIGHT POSITION FOR GAS WITHDRAWAL. TO AVOID SEVERE PERSONAL INJURY OR EQUIPMENT DAMAGE, SUPPLY CYLINDERS MUST BE SECURED IN SUCH A MANNER (E.G., CHAIN) AS TO PREVENT THEIR BEING KNOCKED OVER. TON CONTAINERS MUST BE USED IN A HORIZONTAL POSITION WITH THE TWO VALVES IN A VERTICAL LINE. TON CONTAINERS MUST BE SECURED IN SUCH A MANNER (E.G., CHOCKS) TO PREVENT THEIR ROLLING OUT OF PLACE.

When withdrawing gas from a ton container, connection is made to the upper valve (see Figure 6). Liquid withdrawal is accomplished by connecting to the lower valve.

It is recommended that special 3/8-inch square box wrenches, rather than adjustable wrenches, be used for opening cylinder and ton container valves. Length of the wrench should not exceed eight inches. It is good practice to leave the wrench in place so the valve can be closed quickly in case of an emergency. Maximum discharge can be accomplished with one full turn of the valve. Excessive force must not be used in opening valves. Never strike the wrench with anything other than the heel of the hand. Loosening the packing nut a maximum of 1/2 turn is acceptable, provided the packing nut is tightened after the valve is operated. Contact your chlorine supplier if these procedures do not permit operation of the valve.

Angle valves on tank cars must be opened fully to aid the operation of the excess flow valve.

Always test for leaks before putting new containers in service. The system can be pressurized by opening the container valve and then closing it. The valve can be opened again after it is determined that there are no leaks.

WARNING: ALWAYS WEAR PROTECTIVE CLOTHING WHEN CHECKING FOR LEAKS. REFER TO “PERSONNEL SAFETY” FOR INFORMATION ON HEALTH HAZARDS AND SAFETY PRECAUTIONS.

It is not unusual during humid conditions for condensation to collect on the outside of the container. A buildup of frost on the container indicates that withdrawal rates are too high to permit the surrounding air to supply the heat necessary to evaporate the liquid chlorine. Increasing the circulation of room temperature air past the container may correct the condition. Do not apply direct heat to the container in any way. It may be necessary to shut off the container valve and permit it to warm up again before putting it back in service.

After emptying the container, the valve must be closed before disconnecting to prevent the entry of moisture. After disconnecting, the valve cap and the valve protecting cap or hood must be replaced before the container is moved. Empty containers should be segregated from full containers and should be tagged.

Tank cars are unloaded by means of one of the liquid valves. One of the gas valves can be connected to the system to permit pressure testing with gaseous chlorine rather than liquid. The flexible connection used for tank car unloading must be designed for and installed in such a manner to allow for the significant increase in height as the car unloads. Since

tank car pressure is the only force causing the chlorine to discharge, many cars are padded with dry air by the producer or the user. Reference to Chlorine Institute Pamphlet 66, Chlorine Tank Car Loading, Unloading, Air Padding, Hydrostatic Testing, should be made for information on user air padding. It is essential that air padding pressure be kept as low as possible for satisfactory operation of the chlorination equipment since excessive air padding pressures can have a negative impact on evaporator performance. The depletion of the liquid chlorine supply in the car is accompanied by a sharp drop in tank car pressure.

After the angle valve is closed and the discharge line emptied, the piping may be disconnected. The valve outlet plugs should be replaced and the discharge piping capped immediately.

4 PIPING

4.1 PIPING MATERIALS AND JOINTS

If the chlorinator capacity is low enough, the vacuum regulator or the complete chlorinator may be mounted directly on a cylinder or ton container valve, totally eliminating pressure piping. In this case, reference to the equipment instruction book provides all necessary details.

Pressure connections from all chlorine containers are normally made by means of flexible connections made of copper tubing. Use yoke type connections at container valves. The chlorinator or vacuum regulator instruction book should be referred to for details for use of flexible connections along with the required auxiliary cylinder or ton container valves, header valves, and auxiliary header valves (if required).

WARNING: ALWAYS REPLACE FLEXIBLE CONNECTIONS ANNUALLY (OR SOONER IF THERE IS EVIDENCE OF DEGRADATION).

The usual practice for chlorine liquid or gas pressure lines, at the commonly encountered pressures and temperatures at chlorinator installations, is the use of 3/4 or 1.0 inch schedule 80 carbon steel seamless pipe with Class 3000 forged steel fittings; two-bolt flanges (commonly referred to as oval ammonia unions) are also often used. Both screwed and socket welded construction are common. Threaded joints should be made up using litharge and glycerine for permanent joints, white lead or TFE tape for others.

To facilitate maintenance, the number of line valves should be kept to a minimum. Insulation is required only in those cases where it is necessary to prevent chlorine gas lines from becoming chilled, or liquid lines from becoming overheated.

More complete details, along with ASTM and ANSI specifications, can be obtained by referring to Chlorine Institute Pamphlet 6, Piping Systems For Dry Chlorine.

WARNING: TWO COMMON CAUSES OF CHLORINE PIPING LEAKS ARE:

1. RE-USE OF GASKETS. THIS SHOULD NEVER BE DONE. ALWAYS HAVE AN ADEQUATE SUPPLY ON HAND AND ALWAYS USE NEW GASKETS OF THE CORRECT MATERIAL AND SIZE AS IDENTIFIED ON THE EQUIPMENT PARTS DRAWING.

2. IMPROPERLY MADE-UP THREADED PIPE JOINTS. SEE CHLORINE INSTITUTE MANUAL OR PAMPHLET 6 FOR RECOMMENDED PROCEDURE.

4.2 GAS PIPING INSTALLATION REQUIREMENTS

Reliquefaction of a gas should be avoided. If liquid chlorine is carried downstream to the chlorinator or vacuum piping, it may soften the plastic components and affect their structural strength. Liquid can wash any collected contaminants into the vacuum regulator and can also cause erratic surging, freezing, and pressure release, which can damage the diaphragm and control valves. Cold conditions in a gas pipe line (cold to the touch, dripping of water condensed from the atmosphere, frost, ice) are an indication that liquid chlorine is present in the line and is flashing to gas. Refer to the proper guidelines that follow.

It is important to observe the correct temperature conditions in conducting chlorine gas under pressure from the location of the containers to the point of use. To avoid difficulty with reliquefaction of chlorine, pressure piping and control equipment receiving gas under pressure should be at a higher temperature than that of the chlorine containers. In general, a difference of 5° to 10° F is recommended.

Pitch pressure lines uphill from the gas source toward the chlorinators if possible.

Install a pressure reducing valve or the chlorinator vacuum regulator close to, but higher than, the source of gas. The use of a chlorine pressure reducing valve is also recommended in those localities where severe temperature changes are likely to be encountered during a 24-hour period.

It is preferable to run chlorine pressure gas lines overhead through relatively warm areas rather than along the floor or through basement areas where lower temperatures may be encountered. Do not run these gas lines along exterior walls that may be cold in winter months. Do not run pressure gas lines under windows from which cold air descends in winter months.

If the source of gas is one or more ton containers connected to a manifold, install a drip leg of 1.0-inch schedule 80 seamless steel pipe approximately 18 inches long in a tee in the manifold with the lower end capped. Locate the drip leg immediately downstream of the last container connection to intercept the liquid that comes from the ton containers' gas education tubes when initially opened.

Gas may be withdrawn from two or more containers simultaneously provided all containers are at the same temperature. Refer to Paragraph 3.1.

The installation of chlorine gas strainers in pipe lines upstream from pressure reducing valves or vacuum regulators is a common practice. These strainers can also serve as traps for a small amount of liquid chlorine. Figure 12 illustrates a typical strainer.

4.3 LIQUID PIPING INSTALLATION REQUIREMENTS

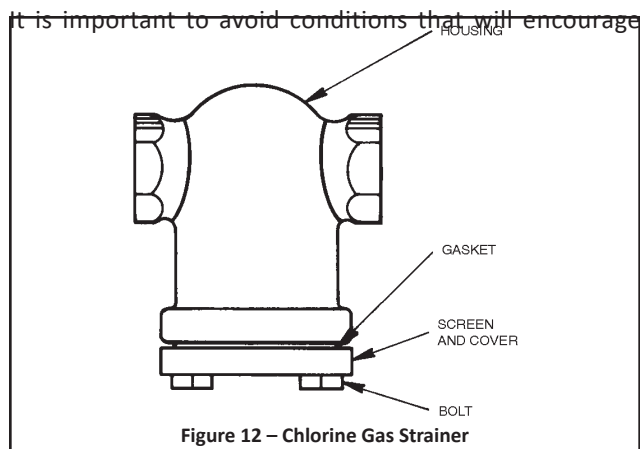

vaporization. Thus it is important to keep liquid chlorine lines as cool as, or cooler than, the containers themselves by eliminating restrictive fittings and always operating with fully opened line valves. Avoid running liquid chlorine lines through overheated areas where gasification is likely.

Valves in liquid chlorine lines should be kept to a minimum. It is particularly important to avoid situations where it is easy to close two valves in a line thus trapping liquid that, upon an increase in temperature, will expand and develop higher than acceptable pressures.

A liquid line pressure relief system (which includes a rupture disc and an expansion chamber) is required where liquid may be trapped in the line or where it is necessary to run lines a considerable distance. The relief system is detailed in Figure 13.

The expansion chamber provides an area for expansion in the event that valves at both ends of the line are closed. Relief system placement must be based not only on length of line but also placement of valves.

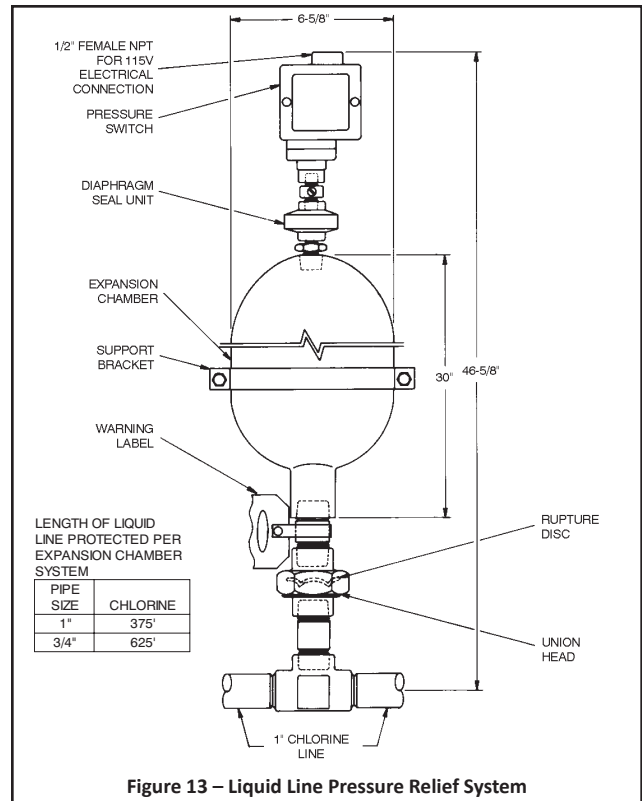

4.4 PRESSURE RELIEF AND VENT PIPING REQUIREMENTS

All pressure relief vent line systems must be treated as though they contain chlorine. Use the same materials for pressure relief vent lines as used for chlorine gas piping, unless the vent line is a combination pressure relief/vacuum relief line in which case the material must be suitable for moist chlorine gas (PVC or polyethylene tubing).

Vent lines must be run in such a way that moisture collecting traps are avoided. A continuous gradient is preferred. The end of all vent lines must be turned down and screened.

Manifolding of vent lines is an acceptable practice provided only like vents are manifolded (i.e., evaporator water vapor vents must be separate from gas pressure reducing valve pressure vents, etc.). The interior cross sectioned area of a common vent or pressure relief line should be approximately equal to the sum of the cross sectional areas of the individual vent lines.

WARNING: THE VENT LINE AND RELIEF LINE MUST TERMINATE IN AN AREA GAS FUMES CANNOT CAUSE INJURY TO PERSONNEL OR DAMAGE. DO NOT TERMINATE THE VENT LINE AND RELIEF LINE AT A LOCATION ROUTINELY USED BY PERSONNEL, SUCH AS WORK AREAS OR PATHWAYS NOR NEAR ANY WINDOWS OR VENTILATION SYSTEM INTAKES. IF AN AREA MEETING THESE REQUIREMENTS IS NOT AVAILABLE, REFER TO THE CHLORINE INSTITUTE'S CHLORINE MANUAL AND PAMPHLET NO. 9 FOR ALTERNATE METHOD OF RELIEF DISPOSAL.

4.5 VALVES

Yoke type auxiliary cylinder, yoke type auxiliary ton container, and header valves are described adequately in the chlorinator or vacuum regulator instruction book.

Line valves are used to isolate alternate sources of supply (manifolded banks of ton containers or tank cars), individual evaporators or pressure type chlorinators. Sufficient line valves should be provided for flexibility of system operation consistent with the recommended practice of eliminating redundant or unnecessary valves.

Valves are usually of approximately globe pattern as shown in Figure 14 or ball type as shown in Figure 15.

Care should be taken that only valves designed by the manufacturer specifically for chlorine service are used. Ball valves must include a provision for venting the cavity in the closed position to the upstream side.

4.6 PRESSURE GAUGES AND SWITCHES

Whenever pressure gauges and switches are used in chlorine liquid or gas lines, they must be of the type protected by a flanged diaphragm seal specifically designed for chlorine service to prevent the entry of chlorine into the gauge or

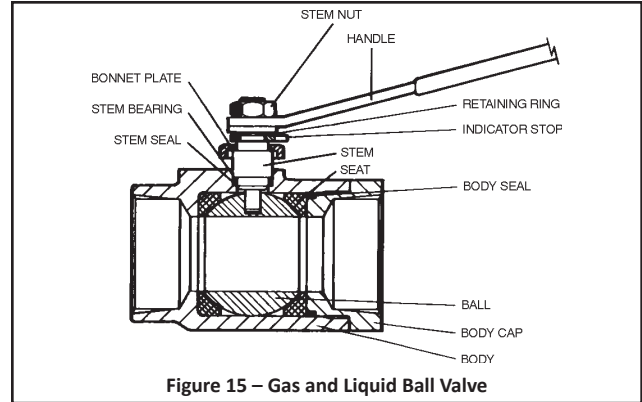

Figure 15 – Gas and Liquid Ball Valve

switch mechanism. The fill material must be suitable for chlorine service. The connection between the seal and the gauge or switch must not be broken. If the connection is inadvertently broken, the complete assembly must be discarded and replaced, unless it can be returned to the manufacturer for repair.

Frequently, valves are installed between chlorine lines and the gauge or switch diaphragm seal to permit removal without taking the line out of service. A means of relieving the pressure in the isolated piping, gauge, or switch is strongly recommended.

WARNING: RELEASING EVEN A SMALL AMOUNT OF LIQUID CHLORINE IS DANGEROUS AND REQUIRES EXTREME CAUTION TO AVOID SEVERE PERSONAL INJURY. ALWAYS USE PROTECTIVE EQUIPMENT WHEN RELIEVING PRESSURE, EVEN IN ISOLATED CHLORINE GAS PIPING.

Since small size line valves for chlorine are not readily available, many times a header valve is used as shown in Figure 16.

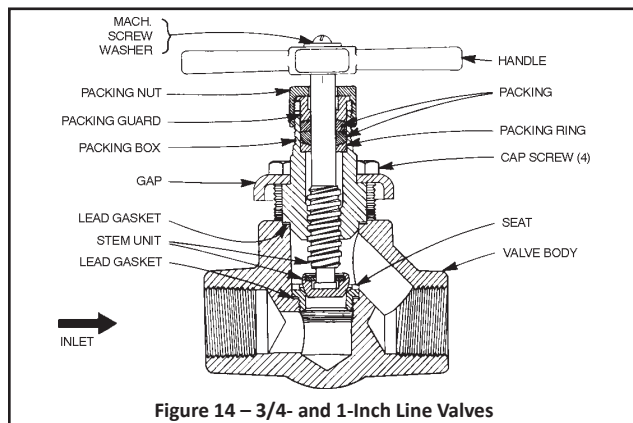

Figure 14 – 3/4- and 1-inch Line Valves

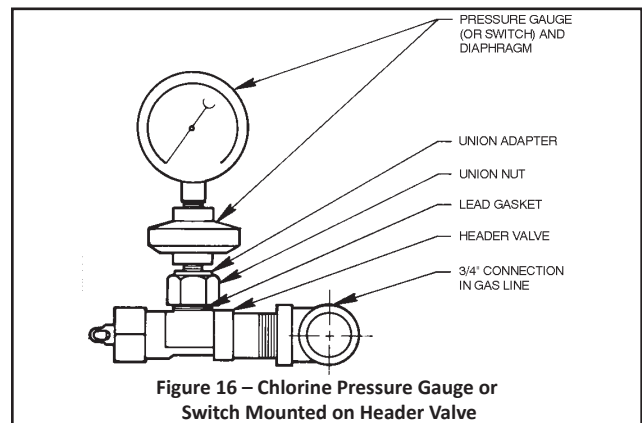

Figure 16 – Chlorine Pressure Gauge or Switch Mounted on Header Valve

4.7 PRESSURE RELIEF DEVICES

There are two types of pressure relief devices in use in chlorine piping systems. The first, as shown in Figure 13, is usually employed in liquid chlorine piping to protect the piping from rupture due to high pressure from thermal expansion of the liquid chlorine. It consists of a rupture disc that ruptures before the pipe line itself can rupture, an expansion chamber that allows for relief of the over-pressure condition without releasing chlorine to the atmosphere, and a pressure switch to warn of the disc rupture.

The second type, as shown in Figure 17, is usually used in gas piping at the evaporator discharge. This system consists of a rupture disc that keeps chlorine out of the valve during normal operation, a pressure relief valve, and a pressure switch to warn of disc rupture.

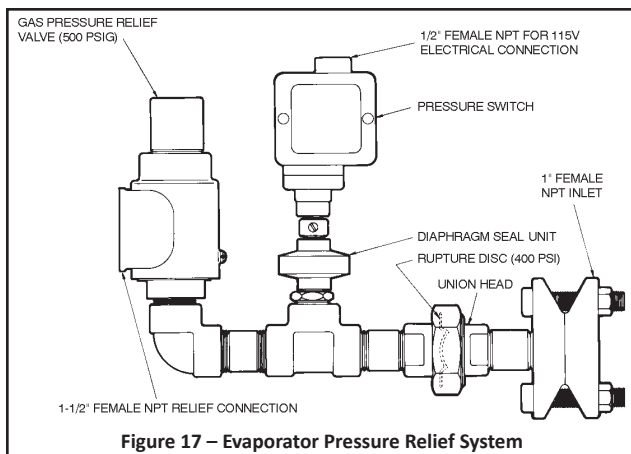

Figure 17 – Evaporator Pressure Relief System

WARNING: THE RELIEF LINE MUST TERMINATE IN AN AREA WHERE GAS FUMES CANNOT CAUSE DAMAGE OR INJURY TO PERSONNEL. DO NOT TERMINATE THE RELIEF LINE AT A LOCATION ROUTINELY USED BY PERSONNEL, SUCH AS WORK AREAS OR PATHWAYS, NOR NEAR WINDOWS OR VENTILATION SYSTEM INTAKES. IF AN AREA MEETING THESE REQUIREMENTS IS NOT AVAILABLE, REFER TO THE CHLORINE INSTITUTE'S CHLORINE MANUAL AND PAMPHLET NO. 9 FOR AN ALTERNATE METHOD OF RELIEF DISPOSAL.

4.8 PREPARATION FOR USE

Normal plumbing practices will result in the entry of cutting oils, greases, and other foreign materials into the piping.

In addition, the line will have been open to the atmosphere during construction, allowing moisture to enter. It is therefore essential that all piping be thoroughly cleaned and dried prior to exposure to chlorine.

WARNING: INCOMPLETE CLEANING CAN RESULT IN VIOLENT REACTIONS BETWEEN CHLORINE AND THESE MATERIALS.

Steam cleaning is an acceptable method for removal of the above materials. Provision must be made for removal of condensate and foreign materials. For alternate methods if steam is not available, refer to Chlorine Institute Pamphlet 6, Piping Systems for Dry Chlorine.

After proper cleaning, all chlorine piping should be hydrostatically tested to one and one half times the expected maximum operating pressure. Prior to testing, all gauges, switches, rupture discs, etc., that could be damaged during testing must be removed and connections plugged. Any moisture absorbing packing or gaskets left in the system during hydrostatic testing must be removed and replaced with new packing or gaskets. After hydrostatic testing, it is essential that all piping be thoroughly dried with inert gas (e.g., nitrogen) or dry air having a dew point of -40° F or below. The dew point of the air or gas leaving the piping must be checked and drying continued until the dew point is at or below -40° F, which may require quite some time.

WARNING: MOISTURE MUST BE REMOVED FROM ANY PART OF THE EQUIPMENT THAT IS NORMALLY EXPOSED TO DRY CHLORINE ONLY. WHILE DRY CHLORINE IS NON-CORROSIVE, MOIST CHLORINE IS EXTREMELY CORROSIVE TO COMMON METALS, SUCH AS BRASS OR STEEL, POSSIBLY RESULTING IN A LEAK AND SEVERE PERSONAL INJURY. ALSO, IF WATER IS TRAPPED IN A SECTION OF PIPING OR EQUIPMENT, SUBSEQUENT HEATING OR FREEZING OF THE WATER MAY RESULT IN HIGH ENOUGH PRESSURE TO RUPTURE THE PIPING OR EQUIPMENT, POSSIBLY CAUSING SEVERE PERSONAL INJURY.

A very acceptable alternate to hydrostatic testing, if proper facilities do not exist for drying, is to test with nitrogen or dry air having a dew point of -40° F or below. The same provision of removing equipment that could be damaged by test pressure applies.

WARNING: TO AVOID SEVERE PERSONAL INJURY, BEFORE PLACING THE PIPING SYSTEM INTO SERVICE, PRESSURE TEST WITH CHLORINE GAS, NOT LIQUID. EACH VOLUME OF CHLORINE LIQUID THAT LEAKS AND THEN EVAPORATES RESULTS IN APPROXIMATELY 460 VOLUMES OF CHLORINE GAS.

The chlorine container valve should be opened only slightly during this phase of testing or preferably closed again after pressurizing the system. The piping should be tested in the smallest sections permitted by the existing valves to minimize

the discharge of chlorine through any leaks.

WARNING: IT IS ESSENTIAL THAT PROPER BREATHING APPARATUS BE AVAILABLE BEFORE CHLORINE IS ADMITTED TO ANY PIPING SYSTEM OR EQUIPMENT. THIS APPARATUS WILL BE DISCUSSED FURTHER UNDER "PERSONNEL SAFETY".

Chlorine leaks are best located using a dauber moistened with commercial 26° Baume' aqueous ammonia (household ammonia is not strong enough) . A white cloud will be formed at the site of any leak. A plastic squeeze bottle that directs ammonia vapor, not liquid, at the joint being tested may also be used.

When a leak is detected, the system must be depressurized before corrective action is taken. The best method of depressurizing the system is through one of the chlorinators. At least one chlorinator must be readily available for this purpose before testing with chlorine begins.

5 PERSONNEL SAFETY

5.1 GENERAL

Proper consideration of personnel safety begins with the provision of properly sized and arranged housing so that operating personnel have adequate room to perform their duties. It is preferable that any room used for chlorine storage or equipment have two doors that open outward and that are equipped with panic bars.

Rooms housing chlorination equipment, and chlorine containers that are "in service" or "in reserve", should be heated when the room temperature falls below 50° F. Comfortable working temperatures of 65° to 75° F are recommended for the chlorine equipment room. The temperature of the chlorine container room (if separate) should normally be 5° to 10° F lower. All common methods of heating are acceptable, provided that care is taken to prevent overheating of chlorine containers. Radiators should not be located adjacent to containers. If space heaters are used, the warm air should be deflected away from the containers. Outside windows should be located or screened so that the rays of the sun do not fall directly on chlorine containers.

Natural ventilation may be adequate for a small chlorinator installation in a separate building when windows and doors can provide cross circulation; however, ventilation by means of a proper type electric fan is always recommended.

In all cases, installations must comply with appropriate regulations.

5.2 HEALTH HAZARDS

Exposure to a sufficiently high concentration of chlorine can result in difficulty in breathing and, if prolonged, finally death through suffocation. Chlorine's strong pungent odor may result in detection at levels as low as 1.0 ppm and most people will detect it by the time the concentration reaches 3.5 ppm. Concentrations of 5 ppm or more are so objectionable that only those who are unconscious or trapped will normally remain in the area. Increasing concentrations will produce eye irritation, coughing, throat irritation, vomiting, and labored breathing.

Even concentrations below the threshold of smell can result in minor eye and throat irritation if the exposure is long enough.

Liquid chlorine can cause burns and/or irritation when it is in contact with the skin or eyes.

Medical attention should be obtained immediately for personnel who have sufficient exposure to result in any symptoms beyond minor irritation. Properly trained and equipped first aid personnel are usually the first line of defense. While waiting for their arrival, the exposed individual must be removed to a safe area and be placed in a comfortable position. If breathing has stopped, artificial respiration must be started immediately. CPR administered by properly trained personnel is required if the heart has stopped.

If the exposed individual has difficulty breathing, oxygen should be administered only by those adequately trained in the procedure and the equipment used.

The proper procedure for emergency treatment of clothing or skin contaminated by chlorine is to flush the area with large quantities of water under a shower for at least 15 minutes. While still under the shower, affected clothing should be removed. No medical treatment or neutralization of the chlorine should be attempted except as directed by a physician.

Immediate flushing with tepid water should be administered if even small quantities of chlorine enter the eye or if the eye has been exposed to strong concentrations of chlorine. The eyelids must be parted and thorough flushing continued for at least 15 minutes. As mentioned previously for skin exposure, no medical treatment or neutralization should be attempted except as directed by a physician.

The attending physician may wish to refer to a Material Safety Data Sheet on chlorine as well as to the Chlorine Institute's Chlorine Manual and/or Pamphlet 63, First Aid and Medical Management of Chlorine Exposures.

5.3 SAFETY PRECAUTIONS

The first steps to be taken in providing proper safety precautions at any facility are the selection of safety equipment to be on hand, the proper location of the equipment, and the training of all personnel in proper procedures to avoid unnecessary chlorine releases and to deal with releases that occur.

Proper respiratory equipment is essential for all facilities regardless of size. For maximum safety, it is preferable to use air tank type pressure demand masks that have a self-contained air supply and, therefore, are suitable regardless of chlorine concentration.

All respiratory equipment must meet the requirements of the National Institute for Occupational Safety and Health. Following the respiratory equipment manufacturer's recommendation regarding maintenance and periodic testing is essential. This equipment should be stored outside the area containing chlorine or chlorine equipment in a manner protecting it from damage of any kind and so as to be readily available.

WARNING: DO NOT LOCK CABINETS OR CLOSETS IN WHICH RESPIRATORY EQUIPMENT IS STORED, AS THE EQUIPMENT MUST BE READILY AVAILABLE.

All personnel with no assigned responsibility for dealing with a chlorine release should be instructed to leave the area. Those responsible for correcting the situation should don respiratory equipment before doing so.

Protective clothing is recommended for handling even routine operations involving chlorine. In the event of a substantial release, protective clothing is required. Anyone desiring further information on protective clothing should refer to the Chlorine Institute Pamphlet 65, Protective Clothing for Chlorine.

Safety shoes, hard hats, and safety glasses should be used in accordance with standard plant practice.

Most leaks will occur in piping, valves, connections, and the pressurized portions of chlorine equipment. These leaks will usually be eliminated by tightening packing, replacing gaskets, or repairing the equipment.

WARNING: REPLACE FLEXIBLE CONNECTIONS ANNUALLY, OR SOONER IF THERE IS EVIDENCE OF DETERIORATION.

Emergency kits (meeting Chlorine Institute requirements) are available that can seal off most leaking areas of chlorine

containers (i.e., valves, fusible plugs, or container wall). If these are on hand they must be used only by personnel thoroughly familiar with their use. The chlorine supplier should be contacted immediately for information, assistance, and advice on the disposition of the leaking container. The container should always be repositioned, if possible, so the leak is gas rather than liquid.

WARNING: NEVER UNDER ANY CIRCUMSTANCE SPRAY WATER ON A CHLORINE LEAK. THIS WILL ONLY MAKE IT WORSE.

Wall charts are available from most chlorine suppliers that provide much of the information contained in this manual.

5.4 EMERGENCY ACTION PLANS

The best emergency plan includes routine practices that are designed to minimize emergencies. Proper maintenance of all equipment associated with the storage, handling, and use of chlorine in accordance with the manufacturer's instructions is essential.

All equipment and piping containing chlorine under pressure must be tested periodically for leaks following procedures covered in Paragraph 4.8. Since it is not unusual for areas used for chlorine storage and chlorine equipment to be relatively unattended, it is important for the air in these areas to be monitored continuously with chlorine detectors, so that warning of leaks is given as early as possible. As with most emergencies, the earliest detection helps to minimize the damage to equipment and personnel. In addition to warning of leaks when the areas are unattended, chlorine detectors should warn of the presence of minor amounts of chlorine that may not be detected by personnel in the area.

Some chlorine leaks are minor but all require immediate attention.

In the event of a major release of chlorine, there should be no delay in contacting the agency in the community that is responsible for handling hazardous material releases. Appropriate names and telephone numbers must be prominently posted.

The chlorine supplier is probably the best source of assistance for most chlorine users. In addition, the Chlorine Institute's Chlorine Emergency Plan (CHLOREP) can provide vital assistance. In the United States this plan is activated through CHEMTREC (toll free 800-4249300). In Canada, contact CANUTEC (call collect 613-996-6666). These names and numbers must also be posted prominently.

The person responsible for making any of the calls listed above must be sure to give the agency contacted complete details including facility name, address, telephone number, and the names(s) of personnel to contact for further information. The description of the emergency should include size of container, corrective action already taken, local weather conditions, injuries, proximity to populated areas, and directions for easiest access to the site.

It is vital that the emergency plan include use of the "buddy system", i.e., no personnel should be allowed to work alone in an area with a chlorine leak even if the second person is only standing by. As indicated earlier, all personnel not involved in locating and correcting the leak should leave the area travelling in a crosswind direction to an area that is upwind and above the leak. Since it may not be possible for all personnel to be equipped with respiratory equipment, they should be instructed to use a wet cloth or handkerchief over the nose and mouth while leaving the area.

Chlorine Institute Pamphlet 64, Emergency Control Planning Checklist for Chlorine Facilities, may be of assistance in preparing the emergency plan. A Material Safety Data Sheet for Chlorine, available from the Institute or the supplier, should also be consulted.

No emergency plan should be implemented until it is reviewed by the chlorine supplier and the agency in the community having responsibility for hazardous material handling and disposal.

If it is apparent that fire will threaten or is present in a chlorine storage area, it is preferable to remove the containers. If this is not possible, the containers must be protected from the heat of the fire by spraying them with water. Do not spray water on any leaking container, however, since water will react with the chlorine, forming acids that will make the leak worse.

5.5 CHEMICAL DISPOSAL FACILITIES

Part of the planning for emergencies entails provision for disposal of any released chlorine. In most cases little can be done about the chlorine already released to the atmosphere except to try to prevent its dissipation into areas where damage to equipment and personnel will result.

At some large installations, scrubbers have been installed so that areas containing chlorine or chlorine equipment can be sealed off and the air removed to a process that will absorb the chlorine. The design of such a system is complex and should only be attempted by those thoroughly familiar with the process.

Absorption systems have been provided at some facilities to permit a leaking container to be emptied quickly if this is deemed essential. One pound of chlorine can be absorbed by 1.4 pounds of sodium hydroxide (caustic soda), 3.7 pounds of sodium carbonate (soda ash), or 1.3 pounds of calcium hydroxide (hydrated lime).

WARNING: TO AVOID SEVERE PERSONAL INJURY WHEN USING CORROSIVE CHEMICALS, OBSERVE ALL SAFETY PRECAUTIONS RECOMMENDED BY THE CHEMICAL MANUFACTURER/ SUPPLIER.

In each case, one pound of the material should be dissolved in one gallon of water. Lime will actually be suspended in, rather than dissolved in, the water and requires constant agitation.

The tank and other equipment provided for an absorption system must be fabricated of materials suitable for the chemicals involved.

Provision must be made for dissolving the chlorine in the alkaline solution in such a way that the solution cannot be sucked back into the container.

Actually the safest way of disposing of the chlorine in the leaking container might be through the chlorination process, particularly if the process can absorb the chlorine at higher than normal rates without creating damage.

It is not generally permissible to ship a container damaged by leak or fire if it contains chlorine. If for some reason this seems necessary, the chlorine supplier must be contacted.