

Technical Manual

**Schedule 80 PVC and CPVC
Schedule 40 PVC
Piping Systems**



+GF+

**GEORG FISCHER
PIPING SYSTEMS**

Table of Contents

Introduction: PVC and CPVC Piping Systems	4
Product Summary	4
Material Data	5-6
Engineering Data	7
Pressure Ratings	7-9
Water Hammer	9-11
Temperature — Pressure Relationship	12
Thermal Expansion and Contraction	13-17
Friction — Loss Characteristics	18-21
Installation Instructions	22
Storage and Handling	22
Solvent Welding	22-27
Threading	28-30
Flanging	31-34
Unions	35-37
Above Ground Installation	38-40
Sunlight and Plastics.....	40
Below Ground Installation	41-43
Standards	44
ASTM	44-45
ASME/ANSI.....	45
NSF/ANSI.....	45
Specifications	46-48
IPS Socket Dimensions	49
Weld Lines in Molded Fittings.....	50
Useful Charts and Conversions	51-53

Introduction: PVC and CPVC Piping Systems

Product Summary

Thermoplastics PVC (Polyvinyl Chloride) and CPVC (Chlorinated Polyvinyl Chloride) are light, flexible, tough and provide exceptional corrosion resistance. Because of these and other properties of a high quality engineered thermoplastic, the savings that can be realized in initial installation and continuing maintenance costs are substantial.

Temperature

PVC can handle temperatures up to 140°F (60°C). CPVC handles temperatures up to 210°F (99°C).

Chemical Resistance

PVC and CPVC thermoplastics are highly resistant to acids, alkalis, alcohols and many other corrosive materials. Both materials are ideal for process piping installation and most service piping applications. For details, please consult our Chemical Resistance Chart or contact your local sales representative.

Maintenance Free Service

PVC and CPVC thermoplastics will not rust, scale, pit or corrode, nor are they subject to electrolysis. You are assured many years of leak-free, maintenance-free service. For buried applications, PVC and CPVC are not affected by soil conditions or galvanic corrosion.

Painting is not required for indoor non-exposed installations. For outdoor installation where the piping may be exposed to significant sunlight, we recommend painting; two coats of a white or light-colored, water-base, outdoor latex paint provides added protection.

Lower Installed Cost

Both PVC and CPVC have installed costs substantially lower than steel alloys or lined steel and are usually more competitive than carbon steel. Solvent cemented connections contribute to this lower installed cost while the much lighter weight (about one-sixth as much as steel) speeds and simplifies handling during installation.

Applications: Versatility and Dependability

PVC and CPVC fittings, pipe and valves have been found suitable for more than 50% of the corrosive and non-corrosive applications within the Chemical Process Industries. Vinyl piping systems have been sold into industrial applications for over 50 years. The establishment of strong industry standards and specifications, plus a third party certification through NSF, provides the specifying engineer, contractor and end user with a tested and accepted piping system to solve their corrosion problems.



Material Data

Physical Properties of Rigid PVC and CPVC Thermoplastic Materials

The following table lists typical physical properties of PVC and CPVC thermoplastic materials. Variations may exist depending on specific compounds and product.

Mechanical

Properties	Unit	PVC	CPVC	Remarks	ASTM Test
Specific Gravity	g/cm ³	1.40 ± .02	1.51 ± .02		D-792
Tensile Strength @ 73°F	PSI	7,200	7,550	Same in Circumferential Direction	D-638
Modules of Elasticity Tensile @ 73°F	PSI	430,000	375,000	Ratio of Stress on Bent Sample at Failure	D-638
Compressive Strength @ 73°F	PSI	9,500	10,100		D-695
Flexural Strength @ 73°F	PSI	13,000	15,100	Tensile Stress/Strain on Bent Sample at Failure	D-790
Izod Impact @ 73°F	Ft-Lbs/In of Notch	1.0	6.3	Impact Resistance of a Notched Sample to a Sharp Blow	D-256
Relative Hardness @ 73°F	Durometer "D" Rockwell "R"	80 ± 3 110-120	80 ± 3 119	Equivalent to Aluminum	D-2240 D-785

Thermodynamics

Properties	Unit	PVC	CPVC	Remarks	ASTM Test
Coefficient of Thermal Linear Expansion per °F	in/in/°F	2.8 x 10 ⁻⁵	3.4 x 10 ⁻⁵		D-696
Thermal Conductivity	BTU/hr/ft ² / F/in	1.3	0.95	Average Specific Heat of 0-100°C	C-177
Specific Heat	CAL/g/°C	0.20-0.28		Ratio of Thermal Capacity to that of Water at 15°C	
Maximum Operating Temperature	°F	140	210	Pressure Rating is Directly Related to Temperature	
Heat Distortion Temperature @ 264 PSI	°F	158	230	Thermal Vibration and Softening Occurs	D-648
Decomposition Point	°F	400+	400+	Scorching by Carbonization and Dehydrochloration	

Flammability

Properties	Unit	PVC	CPVC	Remarks	Test Method
Average Time of Burning	sec.	<5	<5		D-635
Average Extent of Burning	mm	<10	<5		
Flame Spread Index		<10	<10		E-162
Flame Spread		10-25	0-5		E-84
Flash Ignition	°F	730	900		D-1929
Smoke Developed*		1000	285		
Flammability (.062")		V-0	V-0, 5VB 5VA		UL-94
Softening Starts, approx.	°F	250	295		
Material Become Viscous	°F	350	395		
Material Carbonizes	°F	425	450		
Limiting Oxygen Index (LOI)	Vol. %	43	60		D-2863

Other

Properties	Unit	PVC	CPVC	Remarks	ASTM Test
Water Absorption	%	+0.05	+0.03 @ 73°F +0.55 @ 212°F	Weight Gain in 24 Hours	D-570
Poisson's Ratio @ 73°F		0.38	0.27		
ASTM Cell Classification		12454	24448 - Piping 23447 - Fittings		D-1784
Industry Standard Color		Dark Gray/ White	Medium Gray		
NSF Potable Water Approved		Yes	Yes		

Note: This data is based on information supplied by the raw material manufacturers. It should be used as a general recommendation only and not as a guarantee of performance or longevity. The determination of the suitability of any material for a specific application is the responsibility of the end user.

Engineering Data

In the engineering of thermoplastic piping systems, it is necessary to have not only a working knowledge of piping design but also an awareness of a number of the unique properties of thermoplastics.

In addition to chemical resistance, important factors to be considered in designing piping systems employing thermoplastics are

1. Pressure ratings
2. Water hammer
3. Temperature-Pressure relationships
4. Thermal expansion and contraction
5. Friction-loss characteristics

These factors are considered in detail in this manual.

Pressure Rating

Determining pressure-stress pipe relationships

ISO Equation: The pressure rating of a pipe is determined by the circumferential stress which results from internal pressure. The relationship between internal pressure, circumferential stress, wall thickness, and diameter is governed by an ISO equation. In various forms this equation is:

$$P = \frac{2S}{R-1} = \frac{2St}{D_o-t} \quad \frac{2S}{P} = \left(\frac{D_o}{t}\right) - 1$$

$$\frac{2S}{P} = R - 1 \quad S = \frac{P(R-1)}{2}$$

Where:

- P = Internal Pressure, psi
- S = Circumferential Stress, psi
- t = Wall Thickness, in.
- D_o = Outside Pipe Diameter, in.
- R = D_o/t

Long-Term Strength: To determine the long-term strength of thermoplastic pipe, lengths of pipe are capped at both ends (see Fig. 1-C) and subjected to various internal pressures, to produce circumferential stresses that will produce failure within 10 to 10,000 hours. The test is run according to ASTM D 1598 — Standard Test for Time Hydrostatic Pressure. The resulting failure points are used in a statistical analysis (outlined in ASTM D 2837) to determine the characteristic regression curve that represents the stress/time-to-failure relationship for the particular

thermoplastic pipe compound under test. This curve is represented by the equation:

$$\text{Log } T = a + b \text{ log } S$$

Where:
a and b are constants describing the slope and intercept of the curve, and T and S are time-to-failure and stress, respectively.

The regression curve may be plotted on a log-log paper, as shown in the Regression Curve figure below, and extrapolated from 10,000 to 100,000 hours (11.4 years). The stress at 100,000 hours is known as the Long Term Hydrostatic Strength (LTHS) for that particular thermoplastic compound. From this (LTHS) the Hydrostatic Design Stress (HDS) is determined by applying the service factor multiplier, as shown on page 8.

Long-Term Strength Test per ASTM D-1598

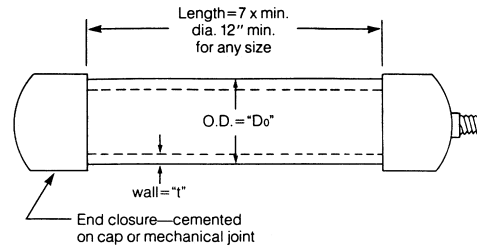
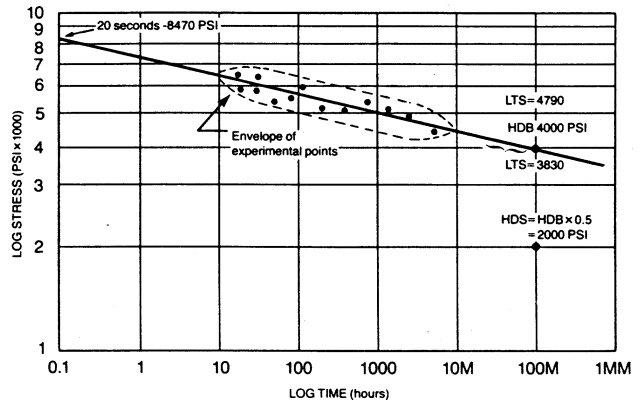

Figure 1-C

Pipe test specimen per ASTM D-1598 for "Time-to-Failure of Plastic Pipe Under Long-Term Hydrostatic Pressure"

Regression Curve — Stress/Time-to-Failure for PVC Type 1



Service Factor: The Hydrostatic Stress Committee of the Plastics Pipe Institute (PPI) has determined that a service (design) factor of one-half the Hydrostatic Design Basis would provide an adequate safety margin for use with water to ensure useful plastic-pipe service for a long period of time. While not stated in the standards, it is generally understood within the industry that this “service life” is a minimum of 50 years.

Accordingly, the standards for plastic pipe, using the 0.5 service factor, required that the pressure rating of the pipe be based upon this Hydrostatic Design Stress, again calculated with the ISO equation.

While early experience indicated that this service factor, or multiplier, of 0.5 provided adequate safety for many if not most uses, some experts felt that a more conservative service factor of 0.4 would better compensate for water hammer pressure surges, as well as for slight manufacturing variations and damage suffered during installation.

The PPI has issued a statement recommending this 0.4 service factor. This is equivalent to recommending that the pressure rating of the pipe should equal 1.25 times the system design pressure for any particular installation. Based upon this calculation, many thousands of miles of thermoplastic pipe have been installed in the United States without failure.

It is best to consider the actual surge conditions, as outlined later in this section. In addition, reductions in working pressure should be considered when handling aggressive chemical solutions and in high-temperature service.

Numerical relationships for service factors and design stresses of PVC and CPVC are shown in the table below.

Service Factors and Hydrostatic Design Stress (HDS)*

(Hydrostatic Design Basis equal 4000 psi) (27.6 MPa)

Service Factor	HDS
0.5	2000 psi (13.8 MPa)
0.4	1600 psi (11 MPa)

*Material: PVC Type I & CPVC

Maximum Pressures: The pressure ratings of thermoplastic pipe represent the maximum allowable operating pressure within a piping system for water at 73°F (22.8°C) based upon a service factor of 0.5.

Maximum Pressure Rating for Schedule 80 PVC/CPVC Pipe at 73°F

Size	PSI	Bar
½"	848	57.7
¾"	688	46.8
1"	630	42.9
1¼"	520	35.4
1½"	471	32.0
2"	404	27.5
2½"	425	28.9
3"	375	25.5
4"	324	22.0
6"	279	19.0
8"	246	16.7
10"	234	15.9
12"	228	15.5

External Pressures — Collapse Rating

Thermoplastic pipe is frequently specified for situations where uniform external pressures are applied to the pipe, such as underwater applications. In these applications, the collapse rating of the pipe determines the maximum permissible pressure differential between external and internal pressures. The basic formulas for collapsing external pressure applied uniformly to a long pipe are:

- For thick wall pipe where collapse is caused by elastic instability of the pipe wall:

$$P_c = \frac{\sigma_c}{2D_o^2} (D_o^2 - D_i^2)$$
- For thin wall pipe where collapse is caused by elastic instability of the pipe wall:

$$P_c = \frac{2cE}{1-\nu^2} \left(\frac{t}{D_m} \right)^3$$

Where:

- P_c = Collapse Pressure (external minus internal pressure), psi
- σ_c = Compressive Strength, psi
- ν = Poisson's Ratio
- E = Modulus of Elasticity, psi
- D_o = Outside Pipe Diameter, in.
- D_m = Mean Pipe Diameter, in.
- D_i = Inside Pipe Diameter, in.
- t = Wall Thickness, in.
- c = Out of Roundness Factor, Approximately 0.66

Choice of Formula: By using formula 2 on thick wall pipe an excessively large pressure will be obtained.

It is therefore necessary to calculate, for a given pipe size, the collapse pressure using both formulas and use the lower value as a guide to safe working pressure. See the following table for short term collapse pressures at 73°F. For long term loading conditions, appropriate long term data should be used.

Vacuum Service

As implied by the collapse rating, thermoplastic pipe is suitable for vacuum or negative pressure conditions that are found in many piping applications.

Laboratory tests have been conducted on Schedule 80 PVC pipe to determine performance under vacuum at temperatures above recommended operating conditions. A 6" pipe showed slight deformation at 165°F and 20 inches of mercury. Above this temperature, failure occurred due to thread deformation.

Conclusion: All sizes of Schedule 80 PVC and CPVC thermoplastic pipe are suitable for vacuum service up to 140°F and 30 inches of mercury. In addition, CPVC may be used up to 210°F. Solvent cemented joints are required for vacuum applications.

Short Term Collapse Pressure in psi at 73°F

1/2"	3/4"	1"	1 1/4"	1 1/2"	2"	3"	4"	6"	8"	10"	12"
Schedule 40 PVC											
2095	1108	900	494	358	211	180	109	54	39	27	29
Schedule 80 PVC/CPVC											
2772	2403	2258	1389	927	632	521	335	215	147	126	117

Note: These are short term ratings; long term should be reduced by 1/3 to 1/2 of the short term ratings.

Water Hammer

Surge pressures due to water hammer are a major factor contributing to pipe failure in liquid transmission systems. A column of moving fluid within a pipe-line, owing to its mass and velocity, contains stored energy. Since liquids are essentially incompressible, this energy cannot be absorbed by the fluid when a valve is suddenly closed.

The result is a high momentary pressure surge called water hammer. The five factors that determine the severity of water hammer are:

1. Velocity
(The primary factor in excessive water hammer; see discussion of "Velocity" and "Safety Factor" below)
2. Modulus of elasticity of pipe material
3. Inside diameter of pipe
4. Wall thickness of pipe
5. Valve closing time

Maximum pressure surges caused by water hammer can be calculated by using the equation below. This surge pressure should be added to the existing line pressure to arrive at a maximum operating pressure figure.

$$P_s = V \left(\frac{E t 3960}{E t + 3 \times 10^5 D_i} \right)^{1/2}$$

Where:

- P_s = Surge Pressure, in psi
- V = Liquid Velocity, in feet per second
- D_i = Inside Pipe Diameter, inch
- E = Modulus of Elasticity of Pipe Material, psi
- t = Wall Thickness, inch

Calculated surge pressure, which assumes instantaneous valve closure, can be calculated for any material using the values for E (Modulus of Elasticity).

However, to keep water hammer pressures within reasonable limits, it is common practice to design valves for closure times considerably greater than 2L/c.

$$T_c > \frac{2L}{c}$$

Where:

- T_c = Valve Closure Time, second
- L = Length of Pipe Run, feet
- c = Sonic Velocity of the Pressure Wave = 4720 ft/second

Velocity

Thermoplastic piping has been successfully installed in systems with a water velocity in excess of 10 feet per second. Thermoplastic pipe is not subject to erosion caused by high velocities and turbulent flow and in this respect is superior to metal piping systems, particularly where corrosive or chemically aggressive fluids are involved. The accepted industry position is that while the maximum safe water velocity in a thermoplastic piping system depends on the specific details of the system and the operating conditions, five feet per second is considered safe. Higher velocities

may be used in systems where the operating characteristics of the valves and pumps are known and sudden changes in flow velocity can be controlled. It is important that the total pressure in the system at any time (operating plus surge or water hammer) not exceed 150 percent of the pressure rating for the system.

Safety Factor

Since the duration of any pressure surges due to water hammer is extremely short — seconds, or more likely, fractions of a second — the calculations used in determining the Safety Factor, the maximum fiber stress due to internal pressure must be compared to some very short-term strength value. Referring to the “Regression Curve” chart on page 7, it shows that the failure stress for very short time periods is very high when compared to the Hydrostatic Design Stress.

Using this premise, the calculation of Safety Factor may be based, very conservatively, on the 20-second strength value given in the “Regression Curve” chart (page 7) — 8470 psi for PVC Type I.

A sample calculation is shown below, based upon the listed criteria:

Pipe = 1½” Schedule 80 PVC I
 O.D. = 1.660; Wall = 0.191
 HDS = 2000 psi

The calculated surge pressure for 1½” Schedule 80 PVC pipe at a velocity of 1 ft/sec. is 26.2 psi/ft/sec. (see next page)

Water Velocity = 5 feet per second
 Static Pressure in System = 300 psi
 Total System Pressure = Total Static + Surge Pressure
 $P_t = P + PS$
 $= 300 + 5 \times 26.2$
 $= 431.0 \text{ psi}$

Maximum circumferential stress is calculated from a variation of the ISO Equation:

$$S = \frac{P_t (D_o - t)}{2t} = \frac{431 (1.660 - 0.191)}{2 \times 0.191} = 1657.4$$

$$\text{Safety Factor} = \frac{\text{20-second strength}}{\text{Maximum stress}}$$

$$= \frac{8470}{1657} = 5.11$$

Surge Pressure, Ps in psi at 73°F

water velocity (ft./sec.)	½"	¾"	1"	1¼"	1½"	2"	3"	4"	6"	8"	10"	12"
Schedule 40 PVC												
1	27.9	25.3	24.4	22.2	21.1	19.3	18.9	17.4	15.5	14.6	13.9	13.4
2	55.8	50.6	48.8	44.4	42.2	38.6	37.8	34.8	31.0	29.2	27.8	26.8
3	83.7	75.9	73.2	66.6	63.3	57.9	56.7	52.2	46.5	43.8	41.7	40.2
4	111.6	101.2	97.6	88.8	84.4	77.2	75.6	69.6	62.0	58.4	55.6	53.6
5	139.5	126.5	122.0	111.0	105.5	96.5	94.5	87.0	77.5	73.0	69.5	67.0
6	167.4	151.8	146.4	133.2	126.6	115.8	113.4	104.4	93.0	87.6	83.4	80.4
Schedule 80 PVC/CPVC												
1	32.9	29.9	28.7	26.2	25.0	23.2	22.4	20.9	19.4	18.3	17.3	17.6
2	65.6	59.8	57.4	52.4	50.0	46.4	44.8	41.8	38.8	36.6	35.6	35.2
3	98.7	89.7	86.1	78.6	75.0	69.6	67.2	62.7	58.2	59.9	53.4	52.8
4	131.6	119.6	114.8	104.8	107.0	92.8	89.6	83.6	77.6	73.2	71.2	70.4
5	164.5	149.5	143.5	131.0	125.0	116.3	112.0	104.5	97.0	91.5	89.0	88.0
6	197.4	179.4	172.2	157.2	150.0	133.2	134.4	125.4	116.4	109.8	106.8	105.6

The "Safety Factors vs. Service Factors" table (see below) gives the results of Safety Factor calculations based upon Service Factors of 0.5 and 0.4 for the 1¼" PVC I Schedule 80 pipe of the example shown on page 10 using the full pressure rating calculated from the listed Hydrostatic Design Stress. In each case, the Hydrostatic Design Basis = 4000 psi, and the water velocity = 5 feet per second.

Safety Factors vs. Service Factors — PVC Type I Thermoplastic Pipe

Pipe Class	Service Factor	HDS, psi	Pressure Rating psi	Surge Pressure at 5 ft./sec.	Maximum Pressure psi	Maximum Stress psi	Safety Factor
1¼" Sch. 80	0.5	2000	520	131.0	651.0	2503.5	3.38
1¼" Sch. 80	0.4	1600	416	131.0	547.0	2103.5	4.03

Pressure Rating values are for PVC I pipe, and for most sizes are calculated from the experimentally determined Long Term Strength of PVC I extrusion compounds. Because molding compounds may differ in Long Term Strength and elevated temperature properties from pipe compounds, piping systems consisting of extruded pipe and molded fittings may have lower pressure ratings than those shown here, particularly at the higher temperatures. Caution should be exercised in design of systems operating above 100°F.

Comparing Safety Factors for this 1¼" Schedule 80 pipe at different Service Factors, it should be noted that changing from a Service Factor of 0.5 to a more conservative 0.4 increases the Safety Factor only by 16%.

Cyclic Fatigue in Vinyl Piping Systems

When discussing water hammer or pressure surge in a piping systems, one should also be aware of a failure mode termed "Cyclic Fatigue." A piping system that has frequent and significant changes in flow conditions or pressure, creating a fluctuating surge, can have an effect on the structural integrity of a thermoplastic fitting. This condition has been observed in golf course irrigation systems that experience tens of thousands of water pressure surges over the course of a year. The resultant failure from cyclic fatigue is

very similar in appearance to long-term static failure and it may be very difficult to ascertain the exact cause of such failures.

However, the design engineer should consider this phenomenon when designing a GF Piping System with frequent pressure changes, particularly if the surge pressure exceeds 50% of the systems working pressure. Based on some testing by Keller-Bliesener Engineering, the engineer may want to consider devaluing the fitting by 40% from the published pipe burst pressure. Keeping the flow velocity to 5 fps or less will also have an effect on pressure surges. Other considerations would be to use actuated valves that can be set to provide a slow opening or to install "soft start" pumps, as both of these will limit the water hammer and the resultant pressure surges.

Temperature-Pressure Relationship

Pressure ratings for thermoplastic pipe are generally determined using water at room temperature (73°F). As the system temperature increases, the thermoplastic pipe becomes more ductile, increases in impact strength and decreases in tensile strength. The pressure ratings of thermoplastic pipe must, therefore, be decreased accordingly.

The effects of temperature have been exhaustively studied and correction (derating) factors developed for each thermoplastic piping material. To determine the maximum operating pressure at any given temperature, multiply the pressure rating for the pipe size and type found in the following table by the temperature derating factor (f).

Solvent-Welded Pressure Rating vs. Service Temperature — PVC and CPVC

Nom. Size (inch)	D Outside Dia	t Wall	DR = D/t	P																							
				73°F		90°F		100°F		110°F		120°F		130°F		140°F		150°F		160°F		180°F		200°F		210°F	
				PVC	CPVC	PVC	CPVC	PVC	CPVC	PVC	CPVC	PVC	CPVC	PVC	CPVC	PVC	CPVC	PVC	CPVC	PVC	CPVC	PVC	CPVC	PVC	CPVC	PVC	CPVC
				f=1.00	f=1.00	f=0.75	f=0.92	f=0.62	f=0.85	f=0.50	f=0.77	f=0.40	f=0.70	f=0.30	f=0.62	f=0.22	f=0.55	f=0.47	f=0.40	f=0.25	f=0.18	f=0.16					
s=2000	s=2000	s=1500	s=1840	s=1240	s=1700	s=1000	s=1540	s=800	s=1400	s=600	s=1240	s=440	s=1000	s=940	s=800	s=500	s=400	s=320									
1/2	0.84	0.15	5.71	848	848	636	780	526	721	424	653	339	594	254	526	187	466	399	339	212	153	136					
3/4	1.05	0.15	6.82	688	688	516	633	426	585	344	530	275	482	206	427	151	378	323	275	172	124	110					
1	1.32	0.18	7.35	630	630	473	580	390	536	315	485	252	441	189	391	139	347	296	252	158	113	101					
1 1/4	1.66	0.19	8.69	520	520	390	478	322	442	260	400	208	364	156	322	114	286	244	208	130	94	83					
1 1/2	1.90	0.20	9.50	471	471	353	433	292	400	236	363	188	330	141	292	104	259	221	188	118	85	75					
2	2.38	0.22	10.89	404	404	303	372	251	343	202	311	162	283	121	250	89	222	190	162	101	73	65					
2 1/2	2.88	0.28	10.42	425	425	319	391	263	361	213	327	170	298	128	264	94	234	200	170	106	77	68					
3	3.50	0.30	11.67	375	375	281	345	233	319	188	289	150	263	113	233	83	206	176	150	94	68	60					
4	4.50	0.34	13.35	324	324	243	298	201	275	162	249	130	227	97	201	71	178	152	130	81	58	52					
6	6.63	0.43	16.34	279	279	209	257	173	237	140	215	112	195	84	173	61	153	131	112	70	50	45					
8	8.63	0.50	17.25	246	246	185	226	153	209	123	189	98	172	74	153	54	135	116	98	62	44	39					
10	10.75	0.59	18.13	234	234	175	215	145	199	117	180	94	164	70	145	51	129	110	94	59	42	37					
12	12.75	0.69	18.56	228	228	171	210	141	194	114	176	91	160	68	141	51	125	107	91	57	41	36					

$$P = \frac{2St}{D-t} = \frac{2S}{DR-1} = P_{73°F} f$$

P = Pressure rating of pipe at service temperatures (psi)

S = Hydrostatic design stress (psi)

D = Outside diameter of pipe (inches)

- 1) Figures for pressure rating at 73°F are rounded off from actual calculated values. Pressure ratings for other temperatures are calculated from 73°F values.
- 2) Pressure rating values are for PVC [12454] and CPVC [24448] pipe and for most sizes are calculated from the experimentally determined long-term strength of PVC and CPVC extrusion compounds. Because molding compounds may differ in long-term strength and elevated temperature properties from pipe compounds, piping systems consisting of extruded pipe and molded fittings may have lower pressure ratings than those shown here, particularly at the higher temperatures. Caution should be exercised when designing PVC systems operating above 100°F and CPVC systems operating above 180°F.
- 3) The pressure ratings given are for solvent-cemented systems. When adding valves, flanges or other components, the system must be derated to the rating of the lowest component. (Pressure ratings: molded or cut threads are rated at 50% of solvent-cemented systems; flanges and unions are 150 psi; for valves, see manufacturer's recommendation.)

Thermal Expansion and Contraction

Thermoplastics exhibit a relatively high coefficient of thermal expansion — as much as ten times that of steel. When designing plastic piping systems, expansion of long runs must be considered. Installation temperature versus working temperature or summer to winter extremes must be considered.

Linear Expansion and Contraction

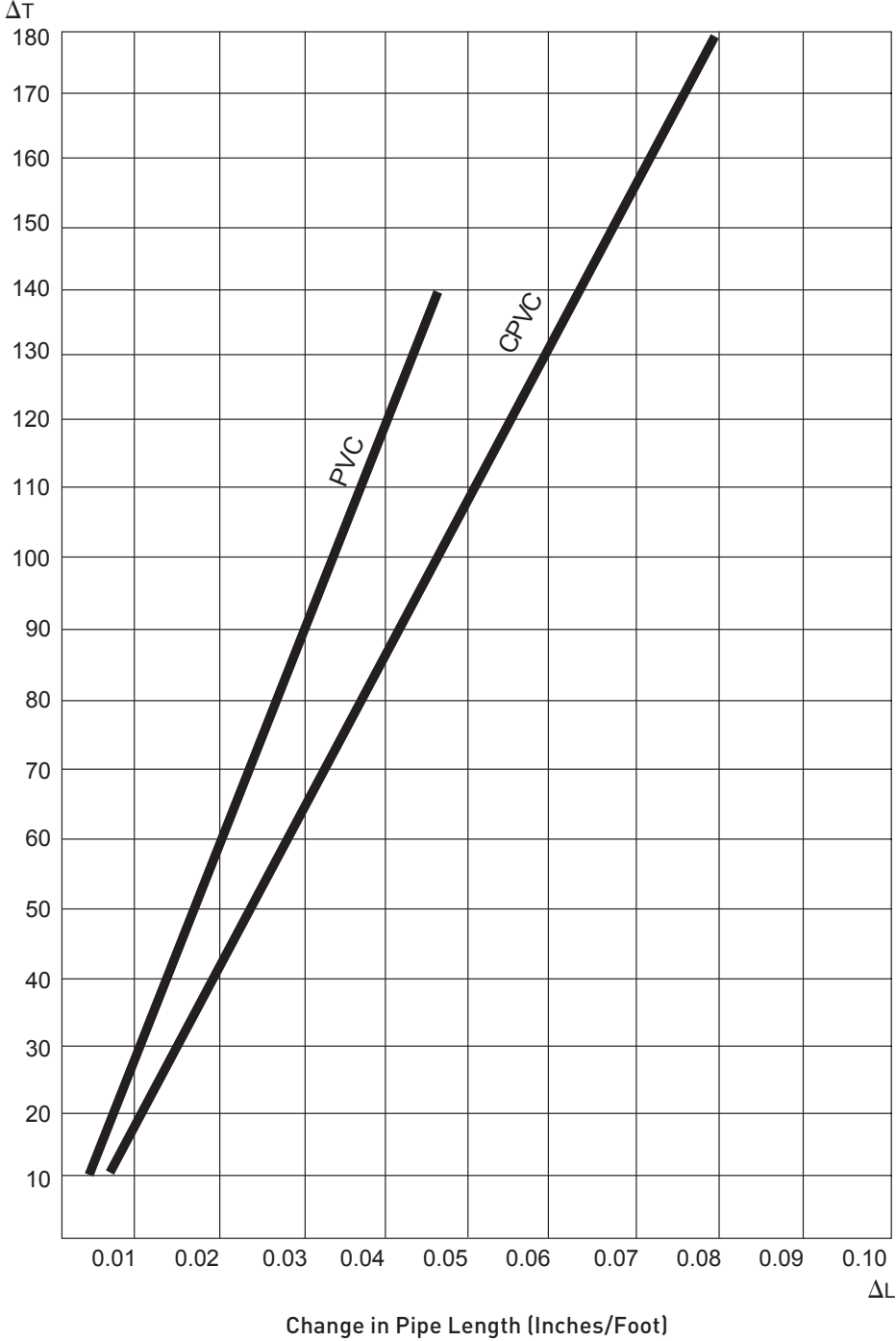

Coefficient of Thermal Linear Expansion

PVC = 2.8×10^{-5} in/in/°F
 CPVC = 3.4×10^{-5} in/in/°F

To Calculate:

ΔL = Change in pipe length due to thermal changes.

L = Straight runs of pipe with no changes in direction.

Y = Coefficient of thermal expansion (see above).

ΔT = maximum change in temperature between installation and operation (T MAX. - T MIN.)

$\Delta L = Y \times L \times \Delta T$

Example:

- A system has 350 feet (4,200") of straight run (L) with no direction change.
- Pipe material is CPVC. Coefficient (Y) is 3.4×10^{-5} (0.000034").
- Pipe is installed at an ambient temperature of 60°F. Maximum anticipated operating temperature is 140°F. The difference (ΔT) is 80°F.

$\Delta L = 0.000034 \times 4200 \times 80$

$\Delta L = 11.4"$ of linear expansion in 350 ft. in pipe.

1. Offsets: Most piping systems have occasional changes in direction which will allow the thermally induced length changes to be taken up in offsets of the pipe beyond the bends. Where this method is employed, the pipe must be able to float except at anchor points.

2. Expansion Joints: Piston type expansion joints can be an effective means of compensating for expansion or contraction when the system has critical dimensions with no room for movement, or where appearance is important. It is important to follow the manufacturers recommendations regarding support, anchoring and the proper setting of the expansion joint.

Tables for expansion loops, offsets and expansion joints have been generated for elevated temperatures as noted beneath each table. If the change in temperature and working temperatures are lower than those used to derive expansion loop and offset tables, the figures will be conservative. These tables can be generated for any temperature and expansion by using the following equations and the modulus of elasticity and working stress at the given temperature.

Assume the pipe to be a cantilevered beam.

For a beam, the bending stress can be calculated by **“Equation 1:”**

$$S = \frac{M * C}{I}$$

Where:

- S = Stress (psi)
- M = Moment (in lbs.)
- C = Distance from neutral axis (in.)
- I = Moment of Inertia (in⁴)

For application to pipe, the maximum stress occurs where C equals the radius of the pipe. Substituting the radius for C and rearranging the equation to solve for the Moment is shown in **“Equation 2:”**

$$M = \frac{2 * S * I}{OD}$$

Where:

- OD = Pipe Outer Diameter (in)
- C = Radius of pipe = OD/2 (in)

The free body diagram which most closely approximates the deflected pipe in an expansion loop, offset or change in direction is shown in Figure A (see page 16). This is not a cantilever beam but rather a guided cantilever beam. For a guided cantilever, the moment induced by an imposed deflection is calculated by **“Equation 3:”**

$$M = \frac{6 * E * I * y}{DPL^2}$$

Where:

- E = Modulus of Elasticity (psi)
- y = imposed deflection (in)
- DPL = deflected pipe length (in)

By equating “2” and “3,” the equation for the deflected beam length (DPL) can be solved:

$$\frac{2 * S * I}{OD} = \frac{6 * E * I * y}{DPL^2}$$

“Equation 4:”

$$DPL = \sqrt{\frac{3 * E * OD * y}{S}}$$

After determining the proper allowable stress, “Equation 4” gives an estimate of the minimum deflected pipe length (DPL) required to sustain a piping thermal movement of length y normal to the piping.

“Equation 4” can be used to calculate the minimum deflected pipe length for expansion loops, offsets and change of directions:

Note: In some cases, a stress intensification factor (i) is added as shown in “Equation 5.” The stress intensification factor is used as a safety factor to account for the effect of localized stresses on piping under repetitive loading. For example, the stress intensification factor for socket welded joints is 1.3 and for threaded joints the factor is 2.3 per ANSI/ASME B31.3, B31.4, B31.5 and B31.8 codes.

“Equation 5:”

$$DPL = \sqrt{\frac{3 * E * OD * y * i}{S}}$$

“Equation 6” is used to calculate the change in length caused by thermal expansion:

$$\Delta L = 12 * e * L * \Delta T$$

Where:

- ΔL = Change in length (in)
- e = Coefficient of Thermal Expansion (in/in °F)
- L = Length of Straight Pipe Run (ft)
- ΔT = Change in Temperature (°F)

For the expansion loop, shown in Figure B (see page 16), the imposed deflection is one-half the change in length as represented in “Equation 7”:

$$y = \frac{\Delta L}{2}$$

“Equation 4” can be modified to replace the deflection (y) with equation 6 for the change in length (ΔL) according to the relationship shown in “Equation 7.”

“Equation 8:” Expansion Loop

$$DPL = 4.243 * \sqrt{\frac{E * OD * e * L * \Delta T}{S}}$$

Where:

- DPL = Deflected Pipe Length (in)
- E = Modulus of Elasticity (psi)
- OD = Pipe Outer Diameter (in)
- e = Coefficients of Thermal Expansion (in/in °F)
- L = Length of Straight Pipe Run (ft)
- ΔT = Change in Temperature (°F)
- S = Allowable Stress (psi)

For the offset shown in Figure C (see page 17) and the change in direction shown in Figure D (page 17), the imposed deflection is equal to the change in length caused by thermal expansion.

“Equation 9:”

$$y = \Delta L$$

“Equation 4” can be modified to replace the deflection (y) with “Equation 6” for the change in length ΔL according to the relationship shown in “Equation 9.”

“Equation 10:” Offsets and Change of Direction

$$DPL = 6.0 * \sqrt{\frac{E * OD * e * L * \Delta T}{S}}$$

Where:

- DPL = Deflected Pipe Length (in)
- E = Modulus of Elasticity (psi)
- OD = Pipe Outer Diameter (in)
- e = Coefficient of Thermal Expansion (in/in °F)
- L = Length of Straight Pipe Run (ft)
- ΔT = Change in Temperature (°F)
- S = Allowable Stress (psi)

“Equation 11” Piston Type Expansion Joints

$$Px = \frac{T_{max} - T_{amb}}{T_{max} - T_{min}} * \Delta L$$

Where:

- Px = Piston Installation Position
- Tmax = Maximum temperature
- Tmin = Minimum Temperature
- Tamb = Ambient Temperature
- ΔL = Length of Expansion Joint (6” or 12”)

Note: In the tables to follow (see page 16), we have chosen to use values for the allowable stress (S) and the modulus of elasticity (E) at the upper temperature limit.

Many calculations (in other manufacturers’ literature) are based on the allowable stress and the modulus of elasticity at ambient conditions. This simplification is allowed because for most plastics (S) and (E) vary with temperature at approximately the same rate.

PVC Expansion Loops

PVC		Length of Run (feet)									
		10	20	30	40	50	60	70	80	90	100
Pipe Size (in.)	O.D. of Pipe (in.)	Minimum Deflected Pipe Length (DPL) (inches)									
1/2	0.840	11	15	19	22	24	27	29	31	32	34
3/4	1.050	12	17	21	24	27	30	32	34	36	38
1	1.315	14	19	23	27	30	33	36	38	41	43
1 1/4	1.660	15	22	26	30	34	37	40	43	46	48
1 1/2	1.900	16	23	28	33	36	40	43	46	49	51
2	2.375	18	26	32	36	41	45	48	51	55	58
3	3.500	22	31	38	44	49	54	58	62	66	70
4	4.500	25	35	43	50	56	61	66	71	75	79
6	6.625	30	43	53	61	68	74	80	86	91	96
8	8.625	35	49	60	69	78	85	92	98	104	110
10	10.750	39	55	67	77	87	95	102	110	116	122
12	12.750	42	60	73	84	94	103	112	119	127	133

PVC Offsets and Change of Directions

PVC		Length of Run (feet)									
		10	20	30	40	50	60	70	80	90	100
Pipe Size (in.)	O.D. of Pipe (in.)	Minimum Deflected Pipe Length (DPL) (inches)									
1/2	0.840	15	22	27	31	34	37	41	43	46	48
3/4	1.050	17	24	30	34	38	42	45	48	51	54
1	1.315	19	27	33	38	43	47	51	54	57	61
1 1/4	1.660	22	30	37	43	48	53	57	61	65	68
1 1/2	1.900	23	33	40	46	51	56	61	65	69	73
2	2.375	26	36	45	51	58	63	68	73	77	81
3	3.500	31	44	54	62	70	77	83	88	94	99
4	4.500	35	50	61	71	79	87	94	100	106	112
6	6.625	43	61	74	86	96	105	114	122	129	136
8	8.625	49	69	85	98	110	120	130	139	147	155
10	10.750	55	77	95	110	122	134	145	155	164	173
12	12.750	60	84	103	119	133	146	158	169	179	189

Figure A: Guided Cantilever Beam

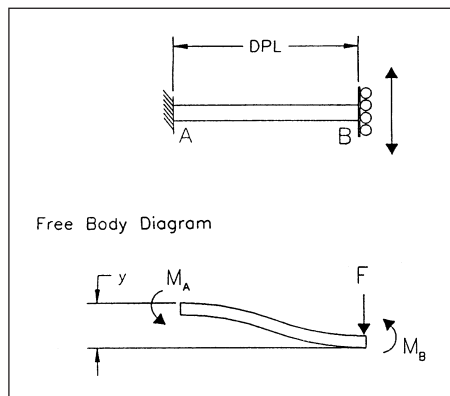
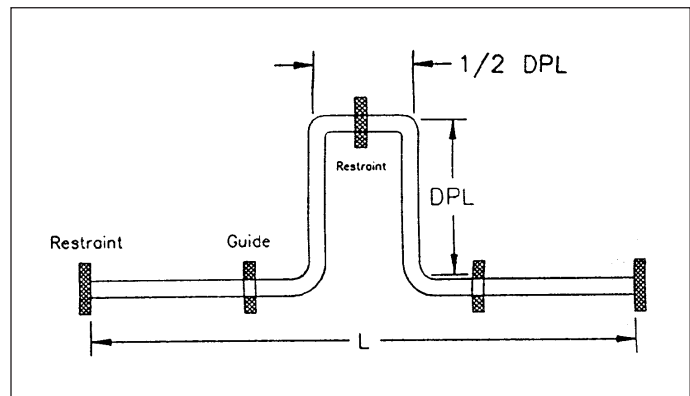

Figure B: Expansion Loop



CPVC Expansion Loops

CPVC		Length of Run (feet)									
		10	20	30	40	50	60	70	80	90	100
Pipe Size (in.)	O.D. of Pipe (in.)	Minimum Deflected Pipe Length (DPL) (inches)									
1/2	0.840	15	21	26	30	33	36	39	42	44	47
3/4	1.050	17	23	29	33	37	40	44	47	50	52
1	1.315	18	26	32	37	41	45	49	52	55	58
1 1/4	1.660	21	29	36	42	46	51	55	59	62	66
1 1/2	1.900	22	31	39	44	50	54	59	63	67	70
2	2.375	25	35	43	50	56	61	66	70	75	79
3	3.500	30	43	52	60	67	71	80	85	91	95
4	4.500	34	48	59	68	77	84	91	97	103	108
6	6.625	42	59	72	83	93	102	110	117	125	131
8	8.625	47	67	82	95	106	116	125	134	142	150
10	10.750	53	75	92	106	118	130	140	150	159	167
12	12.750	58	81	100	115	129	141	152	163	173	182

CPVC Offsets and Change of Directions

CPVC		Length of Run (feet)									
		10	20	30	40	50	60	70	80	90	100
Pipe Size (in.)	O.D. of Pipe (in.)	Minimum Deflected Pipe Length (DPL) (inches)									
1/2	0.840	21	30	36	42	47	51	55	59	63	66
3/4	1.050	23	33	40	47	52	57	62	66	70	74
1	1.315	26	37	45	52	58	61	69	74	78	83
1 1/4	1.660	29	42	51	59	66	72	78	86	88	93
1 1/2	1.900	31	44	54	63	70	77	83	89	94	99
2	2.375	35	50	61	70	79	86	93	99	105	111
3	3.500	43	60	74	85	95	105	113	121	128	135
4	4.500	48	68	84	97	108	119	128	137	145	153
6	6.625	59	83	102	117	131	144	155	166	176	186
8	8.625	67	95	116	134	150	164	177	189	201	212
10	10.750	75	106	130	150	167	183	198	212	224	237
12	12.750	81	115	141	163	182	200	216	230	244	258

Figure C: Expansion Offset

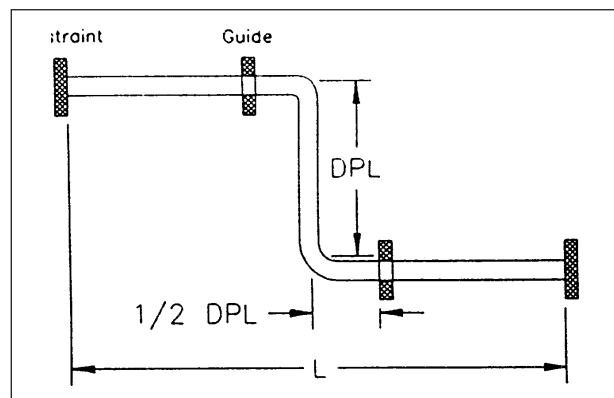
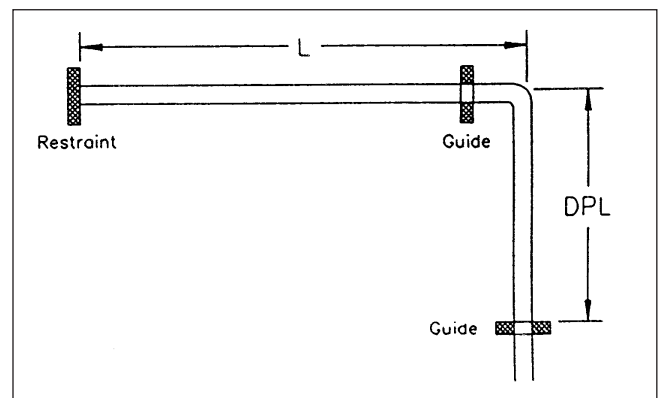

Figure D: Change of Direction



Friction-Loss Characteristics

Introduction

A major advantage of thermoplastic pipe is its exceptionally smooth inside surface area, which reduces friction loss compared to other materials.

Friction loss in plastic pipe remains constant over extended periods of time, in contrast to many traditional materials where the value of the Hazen and Williams C factor (constant for inside roughness) decreases with time. As a result, the flow capacity of thermoplastics is greater under fully turbulent flow conditions like those encountered in water service.

C Factors

Tests made both with new pipe and pipe that had been in service revealed C factor values for plastic pipe between 160 and 165. Thus, the factor of 150 recommended for water in Equation 12 is on the conservative side. On the other hand, the C factor for metallic pipe varies from 65 to 125, depending upon age and interior roughening. A benefit with plastic piping systems is that it is often possible to achieve the desired flow rate using a smaller diameter pipe, resulting in less initial cost for pipe, valves, fitting and pumps, and still maintain the same or even lower friction losses. A longer term benefit would be the resultant savings in energy required to operate the system.

Hazen and Williams Formula

The head losses resulting from various water flow rates in plastic piping may be calculated by means of the Hazen and Williams formula:

“Equation 12:”

$$f = 0.2083 \left(\frac{100}{C} \right)^{1.852} \times \frac{q^{1.852}}{D_i^{4.8655}}$$
$$= 0.0983 \frac{q^{1.852}}{D_i^{4.8655}} \text{ for } C = 150$$
$$P = 4335f$$

Where:

- f = Friction Head in ft. of Water per 100 ft. of Pipe
- P = Pressure Loss in psi per 100 ft. of Pipe
- D_i = Inside Pipe Diameter, in.
- q = Flow Rate in U.S. gal./min.
- C = Constant for Inside Roughness
(C equals 150 for thermoplastics)

Friction Loss — Schedule 40 Pipe

Carrying capacity, friction loss and flow data for Schedule 40 thermoplastic pipe are presented in tabular form in the table below. This table is applicable to pipe made of any of the thermoplastic piping materials as all have equally smooth interior surfaces.

Carrying Capacity and Friction Loss — Schedule 40 Thermoplastics Pipe

Independent variables: Gallons per minute and nominal pipe size O.D. (Min. I.D.)

Dependent variables: Velocity, friction head and pressure drop per 100 feet of pipe, interior smooth.

Gallons per minute	½ in.			¾ in.			1 in.			1¼ in.			1½ in.			2 in.			3 in.			
	Velocity feet per second	Friction head feet	Friction loss pounds per square inch	Velocity feet per second	Friction head feet	Friction loss pounds per square inch	Velocity feet per second	Friction head feet	Friction loss pounds per square inch	Velocity feet per second	Friction head feet	Friction loss pounds per square inch	Velocity feet per second	Friction head feet	Friction loss pounds per square inch	Velocity feet per second	Friction head feet	Friction loss pounds per square inch	Velocity feet per second	Friction head feet	Friction loss pounds per square inch	
1	1.13	2.08	0.90	0.63	0.51	0.22																
2	2.26	4.16	1.80	1.26	1.02	0.44	0.77	0.55	0.24	0.44	0.14	0.06	0.33	0.07	0.03							
5	5.64	23.44	10.15	3.16	5.73	2.48	1.93	1.72	0.75	1.11	0.44	0.19	0.81	0.22	0.09	0.49	0.066	0.029	0.03	0.015	0.007	
7	7.90	43.06	18.64	4.43	10.52	4.56	2.72	3.17	1.37	1.55	0.81	0.35	1.13	0.38	0.17	0.69	0.11	0.048	0.49	0.021	0.009	
10	11.28	82.02	35.51	6.32	20.04	8.68	3.86	6.02	2.61	2.21	1.55	0.67	1.62	0.72	0.31	0.98	0.21	0.091	0.68	0.03	0.013	
15		4 in.			9.48	42.46	18.39	5.79	12.77	5.53	3.31	3.28	1.42	2.42	1.53	0.66	1.46	0.45	0.19	1.03	0.07	0.030
20	0.51	0.03	0.013	12.65	72.34	32.32	7.72	21.75	9.42	4.42	5.59	2.42	3.23	2.61	1.13	1.95	0.76	0.33	1.37	0.11	0.048	
25	0.64	0.04	0.017		5 in.			9.65	32.88	14.22	5.52	8.45	3.66	4.04	3.95	1.71	2.44	1.15	0.50	1.71	0.17	0.074
30	0.77	0.06	0.026	0.49	0.02	0.009	11.58	46.08	19.95	6.63	11.85	5.13	4.85	5.53	2.39	2.93	1.62	0.70	2.05	0.23	0.10	
35	0.89	0.08	0.035	0.57	0.03	0.013				7.73	15.76	6.82	5.66	7.36	3.19	3.41	2.15	0.93	2.39	0.31	0.13	
40	1.02	0.11	0.048	0.65	0.03	0.013				8.84	20.18	8.74	6.47	9.43	4.08	3.90	2.75	1.19	2.73	0.40	0.17	
45	1.15	0.13	0.056	0.73	0.04	0.017				9.94	25.10	10.87	7.27	11.73	5.80	4.39	3.43	1.49	3.08	0.50	0.22	
50	1.28	0.16	0.069	0.81	0.05	0.022	0.56	0.02	0.009	11.05	30.51	13.21	8.08	14.25	6.17	4.88	4.16	1.80	3.42	0.60	0.26	
60	1.53	0.22	0.095	0.97	0.07	0.030	0.67	0.03	0.013				9.70	19.98	8.65	5.85	5.84	2.53	4.10	0.85	0.37	
70	1.79	0.30	0.13	1.14	0.10	0.043	0.79	0.04	0.017							6.83	7.76	3.36	4.79	1.13	0.49	
75	1.92	0.34	0.15	1.22	0.11	0.048	0.84	0.05	0.022							7.32	8.82	3.82	5.13	1.28	0.55	
80	2.05	0.38	0.16	1.30	0.13	0.056	0.90	0.05	0.026		8 in.					7.80	9.94	4.30	5.47	1.44	0.62	
90	2.30	0.47	0.20	1.46	0.16	0.069	1.01	0.06	0.035							8.78	12.37	5.36	6.15	1.80	0.78	
100	2.56	0.58	0.25	1.62	0.19	0.082	1.12	0.08	0.045	0.65	0.03	0.012				9.75	15.03	6.51	6.84	2.18	0.94	
125	3.20	0.88	0.38	2.03	0.29	0.125	1.41	0.12	0.052	0.81	0.035	0.015		10 in.						8.55	3.31	1.43
150	3.84	1.22	0.53	2.44	0.40	0.17	1.69	0.16	0.069	0.97	0.04	0.017							10.26	4.63	2.00	
175	4.48	1.63	0.71	2.84	0.54	0.235	1.97	0.22	0.096	1.14	0.055	0.024								6.16	2.67	
200	5.11	2.08	0.90	3.25	0.69	0.30	2.25	0.28	0.12	1.30	0.07	0.030	0.82	0.027	0.012		12 in.				7.88	3.41
250	6.40	3.15	1.36	4.06	1.05	0.45	2.81	0.43	0.19	1.63	0.11	0.048	1.03	0.035	0.015					11.93	5.17	
300	7.67	4.41	1.91	4.87	1.46	0.63	3.37	0.60	0.26	1.94	0.16	0.069	1.23	0.05	0.022							
350	8.95	5.87	2.55	5.69	1.95	0.85	3.94	0.79	0.34	2.27	0.21	0.091	1.44	0.065	0.028	1.01	0.027	0.012				
400	10.23	7.52	3.26	6.50	2.49	1.08	4.49	1.01	0.44	2.59	0.27	0.12	1.64	0.09	0.039	1.16	0.04	0.017				
450				7.31	3.09	1.34	5.06	1.26	0.55	2.92	0.33	0.14	1.85	0.11	0.048	1.30	0.05	0.022				
500				8.12	3.76	1.63	5.62	1.53	0.66	3.24	0.40	0.17	2.05	0.13	0.056	1.45	0.06	0.026				
750							8.43	3.25	1.41	4.86	0.85	0.37	3.08	0.28	0.12	2.17	0.12	0.052				
1000							11.24	5.54	2.40	6.48	1.45	0.63	4.11	0.48	0.21	2.89	0.20	0.087				
1250										8.11	2.20	0.95	5.14	0.73	0.32	3.62	0.31	0.13				
1500										9.72	3.07	1.33	6.16	1.01	0.44	4.34	0.43	0.19				
2000													8.21	1.72	0.74	5.78	0.73	0.32				
2500													10.27	2.61	1.13	7.23	1.11	0.49				

Friction Loss — Schedule 80 Pipe

Carrying capacity, friction loss and flow data for Schedule 80 thermoplastic pipe are presented in tabular form in the table below. This table is applicable to pipe made of any of the thermoplastic piping materials as all have equally smooth interior surfaces.

Friction Loss — Schedule 80 Fittings

The table "Friction Loss in Equivalent Feet of Pipe" gives the estimated friction loss in equivalent feet of pipe, through thermoplastic fittings of various sizes and configurations.

Carrying Capacity and Friction Loss — Schedule 80 Thermoplastics Pipe

Independent variables: Gallons per minute and nominal pipe size O.D. (Min. I.D.)

Dependent variables: Velocity, friction head and pressure drop per 100 feet of pipe, interior smooth.

Gallons per minute	1/2"			3/4"			1"			1 1/4"			1 1/2"			2"			2 1/2"			3"		
	Velocity feet per second	Friction head feet	Friction loss pounds per square inch	Velocity feet per second	Friction head feet	Friction loss pounds per square inch	Velocity feet per second	Friction head feet	Friction loss pounds per square inch	Velocity feet per second	Friction head feet	Friction loss pounds per square inch	Velocity feet per second	Friction head feet	Friction loss pounds per square inch	Velocity feet per second	Friction head feet	Friction loss pounds per square inch	Velocity feet per second	Friction head feet	Friction loss pounds per square inch	Velocity feet per second	Friction head feet	Friction loss pounds per square inch
1	1.43	4.02	1.74	0.74	0.86	0.37																		
2	2.95	8.03	3.48	1.57	1.72	0.74	0.94	0.88	0.33	0.52	0.21	0.09	0.38	0.10	0.041									
5	7.89	45.23	19.59	3.92	9.67	4.19	2.34	2.78	1.19	1.30	0.66	0.29	0.94	0.30	0.126	0.56	0.10	0.040	0.39	0.05	0.022	0.25	0.02	0.009
7	10.34	83.09	35.97	5.49	17.76	7.59	3.23	5.04	2.19	1.82	1.21	0.53	1.32	0.55	0.24	0.78	0.15	0.088	0.54	0.07	0.032	0.35	0.023	0.013
10				7.84	33.84	14.65	4.68	9.61	4.16	2.60	2.30	1.00	1.88	1.04	0.45	1.12	0.29	0.13	0.78	0.12	0.052	0.50	0.04	0.017
15				11.76	71.70	31.05	7.01	20.36	8.82	3.90	4.87	2.11	2.81	2.20	0.95	1.63	0.62	0.27	1.17	0.26	0.11	0.75	0.09	0.039
20	0.57	0.04	0.017				9.35	34.68	15.02	5.20	8.30	3.59	3.75	3.75	1.62	2.23	1.06	0.46	1.56	0.44	0.19	1.00	0.15	0.055
25	0.72	0.06	0.026				11.69	52.43	22.70	6.50	12.55	5.43	4.69	5.67	2.46	2.79	1.60	0.69	1.95	0.67	0.29	1.25	0.22	0.095
30	0.86	0.08	0.035	0.54	0.03	0.013	14.03	73.48	31.62	7.80	17.59	7.62	5.63	7.95	3.44	3.35	2.25	0.97	2.34	0.94	0.41	1.49	0.31	0.13
35	1.00	0.11	0.048	0.63	0.04	0.017				9.10	23.40	10.13	6.57	10.58	4.58	3.91	2.99	1.29	2.73	1.25	0.64	1.74	0.42	0.13
40	1.15	0.14	0.061	0.72	0.04	0.017				10.40	29.97	12.98	7.50	13.55	5.87	4.47	3.86	1.66	3.12	1.60	0.89	1.99	0.54	0.23
45	1.29	0.17	0.074	0.81	0.05	0.020				11.70	37.27	16.14	8.44	16.85	7.30	5.03	4.76	2.07	3.51	1.90	0.86	2.24	0.67	0.29
50	1.43	0.21	0.091	0.90	0.07	0.030	0.63	0.03	0.013	13.00	45.30	19.61	9.38	20.48	8.87	5.58	5.79	2.51	3.90	2.42	1.05	2.49	0.81	0.35
60	1.72	0.30	0.13	1.08	0.10	0.043	0.75	0.04	0.017				11.26	28.70	12.43	6.70	8.12	3.52	4.68	3.39	1.47	2.98	1.14	0.49
70	2.01	0.39	0.17	1.26	0.13	0.056	0.88	0.05	0.022							7.82	10.80	4.68	5.46	4.51	1.35	3.49	1.51	0.65
75	2.15	0.45	0.19	1.35	0.14	0.061	0.94	0.06	0.026							8.38	12.27	5.31	5.85	5.12	2.22	3.74	1.74	0.74
80	2.29	0.50	0.22	1.44	0.16	0.069	1.00	0.07	0.030							8.93	13.83	5.99	6.24	6.77	2.50	3.99	1.94	0.84
90	2.58	0.63	0.27	1.62	0.20	0.087	1.13	0.08	0.035							10.05	17.20	7.45	7.02	7.18	3.11	4.48	2.41	1.04
100	2.87	0.76	0.33	1.80	0.24	0.10	1.25	0.10	0.043							11.17	20.90	9.05	7.80	8.72	3.78	4.98	2.93	1.27
125	3.59	1.16	0.50	2.25	0.37	0.16	1.57	0.16	0.068	0.90	0.045	0.019						9.75	13.21	5.72	6.23	4.43	1.92	
150	4.30	1.61	0.70	2.70	0.52	0.23	1.88	0.22	0.095	1.07	0.05	0.022						11.70	18.48	8.00	7.47	6.20	2.68	
175	5.02	2.15	0.93	3.15	0.69	0.30	2.20	0.29	0.12	1.25	0.075	0.033										8.72	8.26	3.58
200	5.73	2.75	1.19	3.60	0.88	0.38	2.51	0.37	0.16	1.43	0.09	0.039	0.90	0.036	0.015							9.97	10.57	4.58
250	7.16	4.16	1.81	4.50	1.34	0.58	3.14	0.56	0.24	1.79	0.14	0.61	1.14	0.045	0.02							12.46	16.00	8.93
300	8.60	5.33	2.52	5.40	1.87	0.81	3.76	0.78	0.34	2.14	0.20	0.087	1.36	0.07	0.03									
350	10.03	7.76	3.35	6.30	2.49	1.08	4.39	1.04	0.45	2.50	0.27	0.12	1.59	0.085	0.037	1.12	0.037	0.016						
400	11.47	9.93	4.30	7.19	3.19	1.38	5.02	1.33	0.68	2.86	0.34	0.15	1.81	0.11	0.048	1.28	0.05	0.022						
450				8.09	3.97	1.72	5.64	1.65	0.71	3.21	0.42	0.18	2.04	0.14	0.061	1.44	0.06	0.026						
500				8.99	4.82	2.09	6.27	2.00	0.87	3.57	0.51	0.22	2.27	0.17	0.074	1.60	0.07	0.030						
750							9.40	4.25	1.84	5.36	1.08	0.47	3.40	0.36	0.16	2.40	0.15	0.065						
1000							12.54	7.23	3.13	7.14	1.84	0.80	4.54	0.61	0.26	3.20	0.20	0.11						
1250										8.93	2.78	1.20	5.67	0.02	0.40	4.01	0.40	0.17						
1500										10.71	3.89	1.68	6.80	1.29	0.56	4.81	0.55	0.24						
2000													9.07	2.19	0.95	6.41	0.84	0.41						
2500													11.34	3.33	1.44	8.01	1.42	0.62						
3000																9.61	1.99	0.86						
3500																11.21	2.65	1.15						
4000																12.82	3.41	1.48						

Friction Loss in Equivalent Feet of Pipe — Schedule 80 Thermoplastics Fittings

Nominal Pipe Size, In.	3/8	1/2	3/4	1	1 1/4	1 1/2	2	2 1/2	3	3 1/2	4	6	8
Tee, Side Outlet	3	4	5	6	7	8	12	15	16	20	22	32	38
90° Ell	1 1/2	1 1/2	2	2 3/4	4	4	6	8	8	10	12	18	22
45° Ell	3/4	1	1 1/8	1 3/8	1 3/4	2	2 1/2	3	4	4 1/2	5	8	10
Insert Coupling	—	1/2	3/4	1	1 1/4	1 1/2	2	3	3	—	4	6 1/4	—
Male-Female Adapters	—	1	1 1/2	2	2 3/4	3 1/2	4 1/2	—	6 1/2	—	9	14	—

Head Loss Characteristics of Water Flow Thru Rigid Plastic Pipe

This nomograph provides approximate values for a wide range of plastic pipe sizes. More precise values should be calculated from the Hazen and Williams formula. Experimental test value of C (a constant

for inside pipe roughness) ranges from 155 to 165 for various types of plastic pipe. Use of a value of 150 will ensure conservative friction loss values.

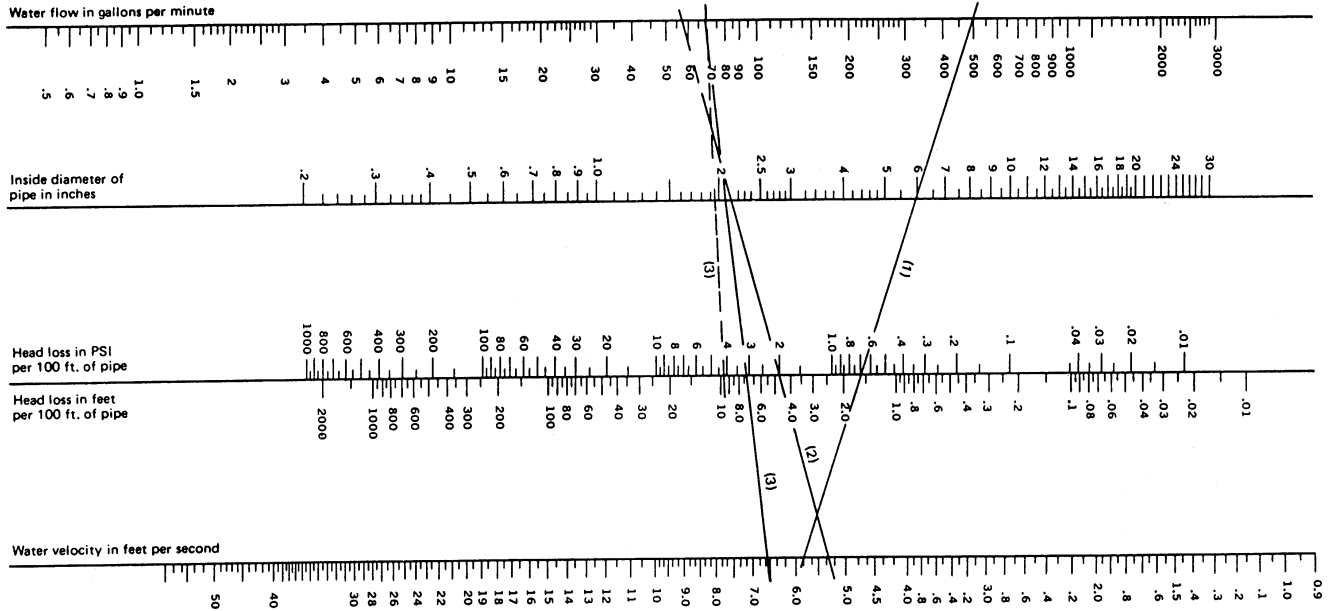

The values of this chart are based on the Hazen & Williams formula:

$$f = 0.2083 \left(\frac{100}{C} \right)^{1.852} \times \frac{g^{1.852}}{D_i^{4.8655}}$$

$$= 0.0983 \frac{g^{1.852}}{D_i^{4.8655}} \text{ for } C = 150$$

$$P = 4335f$$

Where:

- f = Friction Head in ft. of Water per 100 ft. of Pipe
- P = Pressure Loss in psi per 100 ft. of Pipe
- D_i = Inside Pipe Diameter, in.
- g = Flow Rate in U.S. gal./min.
- C = Constant for Inside Roughness
(C equals 150 for thermoplastics)

The nomograph is used by lining up values on the scales by means of a ruler or straight edge. Two independent variables must be set to obtain the other values. For example: line (1) indicates that 500 gallons per minute may be obtained with a 6-inch inside diameter pipe at a head loss of about 0.65 pounds per square inch at a velocity of 6.0 feet per second. Line (2) indicates that a pipe with 2.1 inch inside diameter will give a flow of about 60 gallons per minute at a loss in head of 2 pounds per square inch per 100 feet of pipe. Line (3) and dotted line (3) show that in going from a pipe 2.1 inch inside diameter to one of 2 inches inside diameter, the head loss goes from 3 to 4 pounds per square inch in obtaining a flow of 70 gallons per minute. Remember, velocities in excess of 5.0 feet per second are not recommended.

Nomograph courtesy of Plastics Pipe Institute, a division of The Society of The Plastics Industry.

Installation Instructions

Storage and Handling

GF thermoplastics have excellent resistance to weathering and can be stored outside for long periods. However, it is recommended that any plastic pipe stored outside be covered with a light tarpaulin, or kept under cover in a warehouse or shed that is well ventilated to prevent excessive temperature buildup and possible warping. Care should also be exercised to keep the product away from exposure to UV from direct sunlight. The storage area should not be located near steam lines or other heat sources.

To prevent sagging or "draping," particularly of the longer sections, pipe should be stored on racks that provide close or continuous support. Any sharp edges or burrs on the racks should be removed or covered. To prevent excessive deflection, loose stacks of pipe should not exceed a height of three feet. Bundled pipe can be stacked twice as high.

Fittings and flanges should be kept in their original packaging or in separate bins until they are needed. They should never be mixed with metal piping components.

Since plastic pipe has lower impact strength and resistance to mechanical abuse than steel, it requires somewhat more care in handling. Pulling a length of pipe off a truck bed and letting the free end plummet to the ground should be avoided. Also to be avoided is dragging the pipe over rough ground, dropping heavy objects on it, or using any kind of chains. The resulting scratches, splits or gouges can reduce the pressure rating.

If damage from careless handling does occur, one of the advantages of plastic pipe is readily apparent. The damaged section can be quickly cut out and the pipe ends rejoined using the cutting and joining techniques described below.

Solvent Welding PVC and CPVC Pipe and Fittings

Basic Principles

The solvent cemented connection in thermoplastic pipe and fittings is the last vital link in a plastic pipe

installation. It can mean the success or failure of the system as a whole. Accordingly, it requires the same professional care and attention given to other components of the system.

There are many solvent cementing techniques published covering step by step procedures on just how to make solvent cemented joints. However, we feel that if the basic principles involved are explained, known and understood, a better understanding would be gained, as to what techniques are necessary to suit particular applications, temperature conditions, and variations in sizes and fits of pipe and fittings.

To consistently make good joints the following should be clearly understood:

1. The joining surfaces must be dissolved and made semi-fluid.
2. Sufficient cement must be applied to fill the gap between pipe and fitting.
3. Assembly of pipe and fittings must be made while the surfaces are still wet and fluid.
4. Joint strength develops as the cement dries. In the tight part of the joint the surfaces will tend to fuse together, in the loose part the cement will bond to both surfaces.

Penetration and dissolving can be achieved by a suitable primer, or by the use of both primer and cement. A suitable primer will penetrate and dissolve the plastic more quickly than cement alone. The use of a primer provides a safety factor for the installer for he can know, under various temperature conditions, when he has achieved sufficient softening.

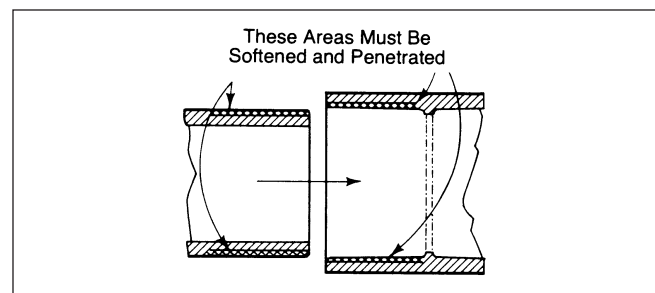

More than sufficient cement to fill the loose part of the joint must be applied. Besides filling the gap, adequate cement layers will penetrate the surface and also remain wet until the joint is assembled. Prove this for yourself. Apply on the top surface of a piece of pipe two separate layers of cement. First apply a heavy layer of cement, then alongside it, a thin brushed out layer. Test the layers every 15 seconds or so by a gentle tap with your finger. You will note that the thin layer becomes tacky and then dries quickly (probably within 15 seconds). The heavy layer will remain wet much longer. Check for penetration a few minutes after applying these layers. Scrape them with a knife. The thin layer will have achieved little or no penetration. The heavy one, much more penetration.

As the solvent dissipates, the cement layer and the dissolved surfaces will harden with a corresponding increase in joint strength. A good joint will take the required working pressure long before the joint is fully dry and final strength will develop more quickly than in the looser (bonded) part of the joint.

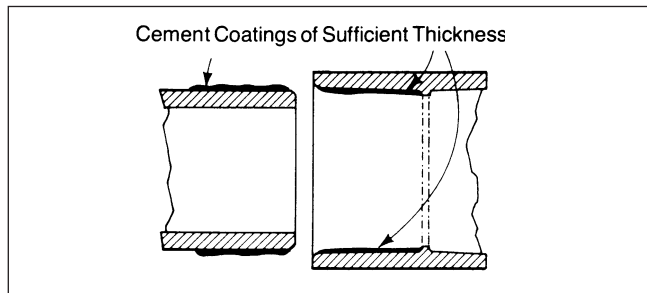
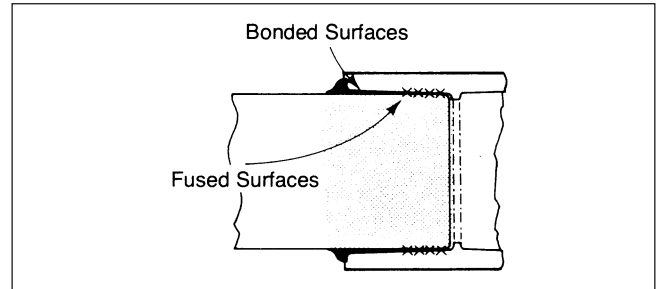

If the cement coatings on the pipe and fittings are wet and fluid when assembly takes place, they will tend to flow together and become one cement layer. Also, if the cement is wet the surfaces beneath them will still be soft, and these softened surfaces in the tight part of the joint will tend to fuse together.

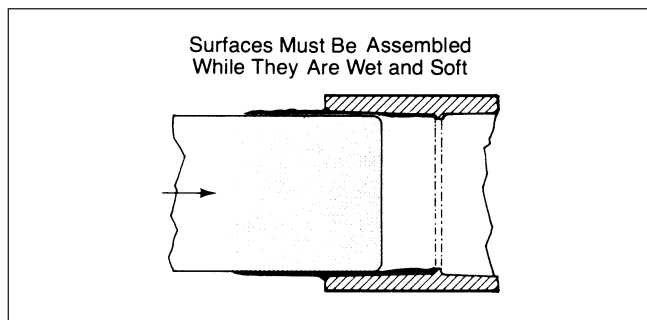

Making the Joint

1. Cutting: Pipe must be squarely cut to allow for the proper interfacing of the pipe end and the fitting socket bottom. This can be accomplished with a miter box saw or wheel type cutter. For saw cuts on pipe too large for a miter box, a pipe wrap should be used and a line drawn with marker. If using a wheel cutter, it must have a cutting blade specifically designed for plastic pipe.

Note: Power saws should be specifically designed to cut plastic pipe.

2. Deburring: Use a plastic deburring tool or file to remove burrs from the end of small diameter pipe. Be sure to remove all burrs from around the inside as well as the outside of the pipe. A slight chamfer (bevel) of about 10°-15° should be added to the end to permit easier insertion of the pipe into the fitting. Failure to chamfer the edge of the pipe may remove cement from the fitting socket, causing the joint to leak. For pressure pipe systems of 2" and above, the pipe must be end-treated with a 15° chamfer cut to a depth of approximately 3/32." Commercial power bevelers are recommended.

3. Test Dry Fit of the Joint: Tapered fitting sockets are designed so that an interference fit should occur when the pipe is inserted about 1/3 to 2/3 of the way into the socket. Occasionally, when pipe and fitting dimensions are at the tolerance extremes, it will be possible to fully insert dry pipe to the bottom of the fitting socket. When this happens, a sufficient quantity of cement must be applied to the joint to fill the gap between the pipe and fitting. The gap must be filled to obtain a strong, leak-free joint.

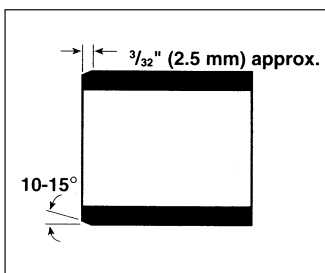

A 15° chamfer cut to a depth of approx. $\frac{3}{32}$."

Step 1:

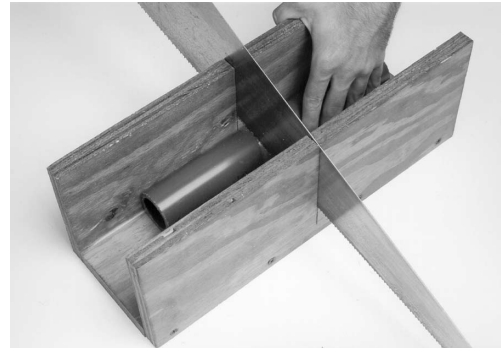

Step 2:



Step 3:



4. Inspection, Cleaning, Priming: Visually inspect the inside of the pipe and fitting sockets and remove all dirt, grease or moisture with a clean, dry rag or cloth. If wiping fails to clean the surfaces, a chemical cleaner must be used. Check for possible damage such as splits or cracks and replace if necessary.

Depth-of-Entry Mark: Marking the depth of entry is a way to check if the pipe has reached the bottom of the fitting socket in step #6. Measure the fitting socket depth and mark this distance on the pipe O.D. We recommend that you add a second mark 2" above this mark as the primer and cement may destroy the first mark and this second line can be used to ensure that the pipe is fully inserted into the fitting socket.

Apply primer to the surface of the pipe and fitting socket using an approved applicator, working the primer in the surface of both the fitting socket and pipe O.D. You should continue to vigorously work the primer into these surfaces until you can feel the applicator start to "drag" indicating a softening of the material. It may take several applications of the primer to effectively break down the surface of the material, but this is a critical step in the cementing process. Move quickly, without hesitation, to the cementing procedure **while the surfaces are still wet** with primer.

Caution: Primers and cements are extremely flammable and must not be stored or used near heat or open flame. Read all warnings on primer and cement cans.

5. Application of Solvent Cement: A critical part of the solvent cementing process is to make sure the cement is well mixed. Periodically cover the container and shake the cement to make sure it stays mixed and uniform. Apply the solvent cement evenly and quickly around the outside of the pipe and at a width a little greater than the depth of the fitting socket while the primer is still wet.

Apply a lighter coat of cement evenly around the inside of the fitting socket. Avoid puddling. Apply a second coat of cementing to the pipe end.

Step 4:

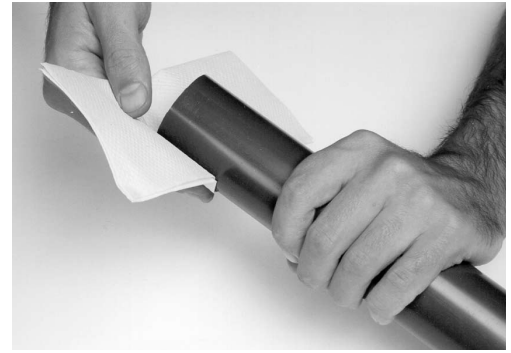

Note: Individual scrape tests may be needed for pipes and fittings from different manufactures or even for pipes of different surface finishes to determine satisfactory penetration and softening of the material.

Step 5:



For sizes 6" and above, and possibly 4" in hot weather, we recommend the consideration of two-man crews to effectively prime both pipe and fitting surfaces and apply the cement while the material is still wet with primer.

Note: When cementing bell-end pipe, be careful not to apply an excessive amount of cement to the bell socket. This will prevent solvent damage to the pipe. For buried pipe applications, do not throw empty primer or cement cans into the trench along side the pipe. Cans of cement and primer should be closed at all times when not in use to prevent evaporation of chemicals and hardening of cement.

6. Joint Assembly: Working quickly, squarely insert the pipe into the fitting socket, giving the pipe or fitting a ¼ turn during insertion to evenly distribute the cement. Do not continue to rotate the pipe after it has hit the bottom of the fitting socket. A good joint will have sufficient cement to form a uniform bead all the way around the outside of the fitting hub. The fitting will have a tendency to slide back on the pipe while the cement is setting, so hold the joint tightly together for about 30 seconds. Please use the cement manufacturer's written recommendations regarding joint set time, for initial movement of a joint, and cure time before a pressure test. For pipe sizes 4" and above, greater axial forces are necessary for the assembly of interference fit joints. Mechanical forcing equipment may be needed to join the pipe and hold the joint until the cement "sets." The joint may have to be held together for up to 3 minutes. Consult the factory for specifics.

Note: Always wait at least 24 hours before pressure testing a piping system to allow cemented joints to cure properly. For colder temperatures, it may be necessary to wait a longer period of time. Please reference the solvent cement manufacturer's curing time.

Note: When using mechanical joining equipment, it will not be possible to apply the ¼ turn as the pipe is inserted into the fitting.

7. Clean-up and Joint Movement: Remove all excess cement from around the pipe and fitting with a dry, cotton rag or cloth. This must be done while the cement is still soft.

The joint should not be disturbed immediately after the cementing procedure and sufficient time should be allowed for proper curing of the joint. Exact drying time is difficult to predict because it depends on variables such as temperature, humidity and cement integrity. For more specific information, contact your solvent cement manufacturer.

**Step 5:
(cont.)**



Note: It may be necessary for two workers to perform this operation for larger sizes of pipe.

Step 6:



Step 7:



Joining Plastic Pipe in Hot Weather

There are many occasions when solvent cementing plastic pipe in 95°F temperatures and over cannot be avoided. At surface temperatures exceeding 110°F, we recommend that the solvent cement manufacturer be contacted. If special precautions are taken, problems can be avoided.

Solvent cements for plastic pipe contain high-strength solvents which evaporate faster at elevated temperatures. This is especially true when there is a hot wind blowing. If the pipe is stored in direct sunlight, surface temperatures may be 20°F to 30°F above air temperature. Solvents attack these hot surfaces faster and deeper, especially inside a joint. Thus it is very important to avoid puddling inside socket and to wipe off excess cement outside.

By following our standard instructions and using a little extra care, as outlined below, successful solvent cemented joints can be made in even the most extreme hot weather conditions.

Tips to Follow When Solvent Cementing in High Temperatures

1. Store solvent cements and primers in a cool or shaded area prior to use.
2. If possible, store fitting and the pipe, or at least the ends to be solvent welded, in shady area before cementing.
3. Cool surfaces to be joined by wiping with a damp rag. Be sure that surfaces dry prior to applying solvent cement.
4. Try to do the solvent cementing in cooler morning hours.
5. Make sure that both surfaces to be joined are still wet with cement when putting them together. With large size pipe, more people on the crew may be necessary.
6. Use a heavier, high viscosity cements since they will provide a little more working time.

As you know, during hot weather there can be a greater expansion-contraction factor.

Joining Plastic Pipe in Cold Weather

Working in freezing temperatures is never easy. But sometimes the job is necessary. If that unavoidable job includes cementing plastic pipe, you can do it successfully with regular cements.

Good Joints Can Be Made at Sub-Zero Temperatures

By following standard instructions and using a little extra care and patience, successful solvent cemented joints can be made at temperatures even as low as -15°F. In cold weather, solvents penetrate and soften the surfaces more slowly than in warm weather. Also the plastic is more resistant to solvent attack. Therefore, it becomes more important to pre-soften surfaces with a primer. And, because of slower evaporation, a longer cure time is necessary. Cure schedules already allow a wide margin for safety. For colder weather, simply allow more time.

Tips to Follow in Solvent Cementing During Cold Weather

1. Prefabricate as much of the system as possible in a heated working area.
2. Store cements and primers in a warmer area when not in use and make sure they remain fluid.
3. Take special care to remove moisture including ice and snow.
4. Use a primer to soften the joining surfaces before applying cement.
5. Allow a longer cure period before the system is used.
6. Read and follow all of our directions carefully before installation.

Regular cements are formulated to have well balanced drying characteristics and to have good stability in sub-freezing temperatures. Some manufacturers offer special cements for cold weather because their regular cements do not have that same stability.

For all practical purposes, good solvent cemented joints can be made in very cold conditions with existing products, provided proper care and a little common sense are used.

Guideline on Cement Usage

Pipe Size	½"	¾"	1"	1¼"	1½"	2"	2½"	3"	4"	6"	8"	10"	12"
No. of Joints	300	200	125	105	90	60	50	40	30	10	5	2-3	1-2

Note: This information is provided as a general guideline. Recommendation is for the number of joints per quart. A Tee will have 3 joints, an Ell will have 2 joints. Our recommendation for primer is to use 150% of the cement number.

Joining PVC and CPVC Systems by NPT Threads

While threaded thermoplastic systems are not recommended for high-pressure systems, piping layouts where leaks would be dangerous, or for larger pipe sizes (more than two inches), they have two definite advantages. They quickly can be dismantled for temporary or take-down applications; and they can be used to join plastic to nonplastic materials.

Following are recommendations for making threaded joints with thermoplastic pipe and fittings.

1. Thread only pipes that have wall thicknesses equal to or greater than those of Schedule 80 pipe.
2. For pressure-rated pipes of PVC and CPVC reduce the pressure rating of threaded pipe to one-half that of unthreaded pipe.
3. To cut the threads, use only pipe dies designed for plastic pipes. Keep the dies clean and sharp. Do not cut other materials with them.
4. Vises for holding the pipe during thread cutting and pipe wrenches should be designed and used in such a manner that the pipe is not damaged. Strap wrenches are recommended. Wooden plugs can be inserted into the end of the pipe, if needed to prevent distortion of the pipe walls and cutting of off-center threads.
5. The following general procedure for cutting threads may be used:
 - A. Use a die stock with a proper guide so the die will start and go on square to the pipe axis. Any burrs or sharp edges on the guide that can scratch the pipe must be removed.
 - B. Do not use cutting oil. However, a drop of oil may be rubbed onto the chasers occasionally. This prevents tearing and helps to promote clean, smooth threads.
 - C. If lubrication is necessary, it is best to use a water based lubricant.
6. Before assembly, the threads should be lubricated and sealed with a non-hardening pipe dope or wrapped with PTFE tape.
7. The proper threading of plastic parts requires some cautions and concerns to maintain the integrity of the threads. Since plastic threads can be easily damaged or cross threaded, it is important that these threads be properly lubricated using a

pipe dope, which is compatible with the materials being threaded, or PTFE tape.

PTFE tape must be installed in a clockwise direction, starting at the bottom of the thread and overlapping each pass. Do not employ more than 3 wraps.

The starting of the thread is critical, to avoid thread damage which could result in a leak. Product must never be installed more than $\frac{1}{2}$ - 1 turn past hand tight and only strap wrenches should be used to tighten plastic connections.

8. In general, applications for threaded plastic pipe fittings fall into two categories:
 - A. Fittings for use in an all-plastic system where both the male and female parts are plastic.
 - B. Fittings for use as transition fittings from plastic to metal.

Theoretically, it is possible to use any combination of threaded parts such as:

1. Metal male to plastic female.
2. Plastic male to plastic female.
3. Metal female to plastic male.

Practical experience, however, suggests that the METAL MALE TO PLASTIC FEMALE combination is more susceptible to premature failure than the other two applications.

The reason for this is due to the incompressibility of metal. Standard instructions call for the male part to be run in hand tight and then tightened $\frac{1}{2}$ turn more. It has been our observation, however, that it is very common to find male metal parts screwed in for a total of 7 to 8 threads. This results in excessively high stress levels in the plastic female part.

The tensile strength of the Type I PVC is 7200 psi. However, all fittings have knit lines (where the melted material joins together after flowing around the core which forms the waterway) which are the weakest portions of the fitting. The tensile strength at the knit lines is therefore lower than the minimum of 7200 psi. A metal nipple screwed in $7\frac{1}{2}$ turns will generate a stress of approximately 6600 psi. This means that if the fitting doesn't crack open immediately, there will probably be a small crack initiated on the inside which

will ultimately cause failure. It is for this reason that GF Piping Systems recommends that its threaded plastic pipe fittings be used only in the following two combinations:

1. PLASTIC MALE TO PLASTIC FEMALE
2. PLASTIC MALE TO METAL FEMALE

If it is absolutely necessary to use a plastic female thread for transition to metal nipple, then it is IMPER-AT-IVE that the nipple not be turned more than 1/2 turn past HANDTIGHT (“fingertight” for strong hands). To insure a leakproof joint, a good sealant is recom-mended PTFE tape or pipe dope).

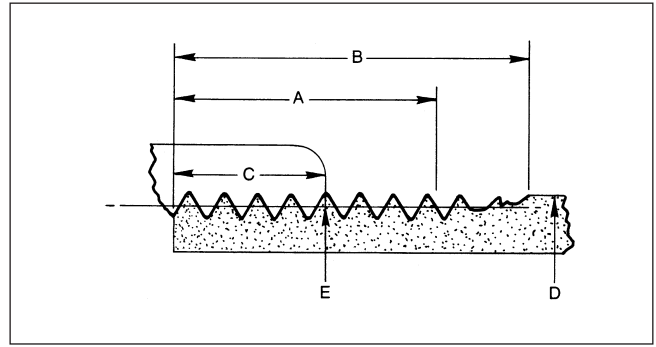

Note: Angle between sides of thread is 60 degrees. Taper of thread, on diameter, is 3/4 inch per foot.

The basic thread is 0.8 x pitch of thread and the crest and root are truncated an amount equal to 0.033 x pitch, excepting 8 threads per inch which have a basic depth of 0.788 x pitch and are truncated 0.045 x pitch at the crest and 0.033 x pitch at the root.

American Standard Taper Pipe Thread Dimensions

Nominal Size (in.)	Pipe		Thread				
	Outside Diameter (in.) D	Number of Threads Per Inch	Normal Engagement by hand (in.) C	Length of Effective Thread (in.) A	Total Length End of Pipe to Vanish Point (in.) B	Pitch Diameter at End of Internal Thread (in.) E	Depth of Thread (Max.) (in.)
1/8	.405	27	.180	.2639	.3924	.39476	.02963
1/4	.540	18	.200	.4018	.5946	.48989	.04444
3/8	.675	18	.240	.4078	.6006	.62701	.04444
1/2	.840	14	.320	.5337	.7815	.77843	.05714
3/4	1.050	14	.339	.5457	.7935	.98887	.05714
1	1.315	11 1/2	.400	.6828	.9845	1.23863	.06957
1 1/4	1.660	11 1/2	.420	.7068	1.0085	1.58338	.06957
1 1/2	1.900	11 1/2	.420	.7235	1.0252	1.82234	.06957
2	2.375	11 1/2	.436	.7565	1.0582	2.29627	.06957
2 1/2	2.875	8	.682	1.1375	1.5712	2.76216	.10000
3	3.500	8	.766	1.2000	1.6337	3.38850	.10000
3 1/2	4.000	8	.821	1.2500	1.6837	3.88881	.10000
4	4.500	8	.844	1.3000	1.7337	4.38713	.10000
5	5.563	8	.937	1.4063	1.8400	5.44929	.10000
6	6.625	8	.958	1.5125	1.9472	6.50597	.10000
8	8.625	8	1.063	1.7125	2.1462	8.50003	.10000
10	10.750	8	1.210	1.9250	2.3587	10.62094	.10000
12	12.750	8	1.360	2.1250	2.5587	12.61781	.10000

Assembling PVC and CPVC Threaded Connections

Please read all instructions before attempting to install threaded parts.

Introduction

NPT threaded connections are not recommended for high pressure systems or those greater than two inches. They also should be avoided in systems where leaks would be dangerous or costly.

When properly installed, threaded connections offer the benefit of an easy and inexpensive transition to metal systems. They can also be used for joining plastic where the installation is expected to be modified or moved later.

Design Considerations

Due to the difference in stiffness between plastic and metal, a metal male-to-plastic female joint must be installed with care and should be avoided if possible.

Only Schedule 80 pipe may be threaded. Threading reduces the rated pressure of the pipe by one-half.

Preparation

Thread Sealant

A thread sealant (or "pipe dope") approved for use with plastic or PTFE tape must be used to seal threads.

Installation

Thread Sealant

Use a thin, even coat of sealant.



PTFE taped must be installed in a clockwise direction, starting at the bottom of the thread and overlapping each pass. Do not employ more than three wraps.

Making the Connection



Start the threaded connection carefully by hand to avoid cross threading or damaging threads. Turn until hand tight. Mark the location with a marker. With a strap wrench on the plastic part, turn an additional half turn.

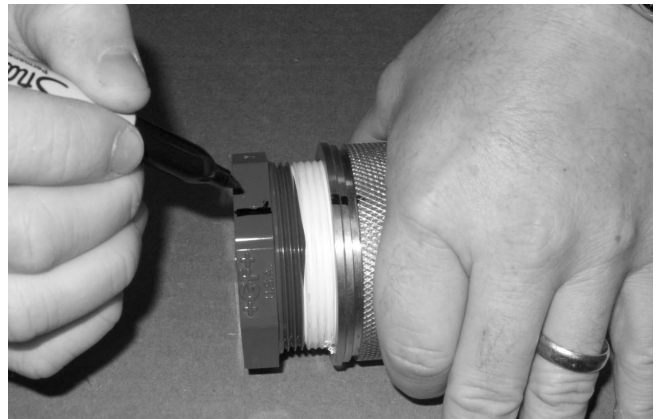

If leakage occurs during pressure testing, consult the chart for next steps.

Connection Type	Next Step
Plastic to Plastic	Tighten up to ½ turn
Plastic Male to Metal Female	Tighten up to ½ turn
Metal Male to Plastic Female	Consult Factory

Alignment

Threaded connections are susceptible to fracture or leaking due to misalignment. Pipe should be installed without bending. See the GF vinyl technical manual for information on guides, support spacing, and allowance for thermal expansion.

Joining PVC and CPVC Systems by Van Stone Flanges

Please read all instructions before attempting to install flanges.

Introduction

When to Use a Flange

Flanges may be used when

- the piping system may need to be dismantled
- the installation is temporary or mobile
- transitioning between dissimilar materials that cannot be cemented together
- the installation environment is not conducive to solvent-cementing

Why Choose a Vinyl Flange?

Like all vinyl pipe and fittings, vinyl flanges are lightweight, inexpensive, and easy to install. However, PVC and CPVC have different physical properties than metals, and therefore special care is required to ensure that your vinyl flanges have a long, reliable service life. Installers should study these instructions and follow them carefully in every installation in order to ensure satisfactory performance and enjoy the full benefits of the GF warranty.

When using a vinyl flange, ensure that the entire system is well-supported and that the flange does not bear the weight of a massive, unsupported system component such as a cast iron valve. See support instructions in the GF Technical Manual online: <http://www.gfpiping.com/downloads/engbook/engbook.pdf>

Materials

Vinyl Flanges

Visually inspect flanges for cracks, deformities, and solvent cement or other obstructions on the sealing surfaces.

Gasket

A rubber gasket must be used between the flange faces in order to ensure a good seal. For Schedule 80 flanges, GF recommends a 0.125" thick, full-face gasket with Shore A scale hardness of 70±5, and the bolt torque values published below are based on this specification. **For other hardness requirements, contact GF Technical Services.** Select the gasket material based on the chemical resistance requirements of your system.

A full-face gasket should cover the entire flange-to-flange interface without extending into the flow path.

Table 1

Gasket Dimensions

Size (in)	O.D. (in, min)	I.D. (in, max)
1/2	3.50	0.88
3/4	3.88	1.10
1	4.25	1.38
1 1/4	4.63	1.60
1 1/2	5.00	1.93
2	6.00	2.44
2 1/2	7.00	2.91
3	7.50	3.59
4	9.00	4.64
6	11.00	6.82
8	13.50	8.66
10	16.00	10.81
12	19.00	12.09

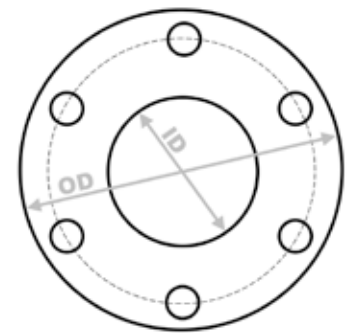

Fasteners

It is critical to avoid excessive compression stress on a vinyl flange. Therefore, only low-friction fastener materials should be used. Low-friction materials allow torque to be applied easily and gradually, ensuring that the flange is not subjected to sudden, uneven stress during installation, which can lead to cracking.

Either the bolt or the nut, and preferably both, should be zinc-plated to ensure minimal friction. If using stainless steel bolt and nut, lubricant must be used to prevent high friction and seizing. In summary, the following fastener combinations are acceptable:

- zinc-on-zinc, with or without lube
- zinc-on-stainless-steel, with or without lube
- stainless-on-stainless, with lube only

Cadmium-plated fasteners, while becoming more difficult to obtain due to environmental concerns, are also acceptable with or without lubrication. Galvanized and carbon-steel fasteners are not recommended. Use a copper-graphite antiseize lubricant to ensure smooth engagement and the ability to disassemble and reassemble the system easily.

Bolts must be long enough that two complete threads are exposed when the nut is tightened by hand. Using a longer bolt does not compromise the integrity of the flange connection, although it wastes material and may make tightening more difficult due to interference with nearby system components.

Table 2
Fastener Specifications

Flange Size (in)	No. of Bolts	Length ¹ (in)	Bolt Size (in) & Type	Washer Size (in) & Type ²
1/2	4	2 1/2	1/2-UNC	1/2 SAE ³
3/4	4	2 1/2	1/2-UNC	1/2 SAE
1	4	2 1/2	1/2-UNC	1/2 SAE
1 1/4	4	3	1/2-UNC	1/2 SAE
1 1/2	4	3	1/2-UNC	1/2 SAE
2	4	3	5/8-UNC	5/8 SAE
2 1/2	4	3 1/2	5/8-UNC	5/8 SAE
3	4	3 3/4	5/8-UNC	5/8 SAE
4	8	4	5/8-UNC	5/8 SAE
6	8	4 3/4	3/4-UNC	3/4 F436 ⁴
8	8	5 1/4	3/4-UNC	3/4 F436
10	12	6	7/8-UNC	7/8 F436
12	12	6 1/2	7/8-UNC	7/8 F436

¹ Suggested bolt length for flange-to-flange connection with 0.125" thick gasket. Adjust bolt length as required for other types of connections.

² Minimum spec. Use of a stronger or thicker washer is always acceptable as long as published torque limits are observed.

³ Also known as Type A Plain Washers, Narrow Series.

⁴ ASTM F436 required for larger sizes to prevent warping at high torque.

A washer must be used under each bolt head and nut. The purpose of the washer is to distribute pressure over a wider area, reducing the compression stress under the bolt head and nut. Failure to use washers voids the GF warranty.

Torque Wrench

Compared to metals, vinyls are relatively flexible and deform slightly under stress. Therefore, not only must bolt torque be controlled in order to avoid cracking the flange, but continuing to tighten the bolts beyond the recommended torque levels may actually make the seal worse, not better.

Because bolt torque is critical to the proper function of a vinyl flange, a current, calibrated torque wrench accurate to within ± 1 ft-lb must be used when installing vinyl flanges.

Experienced installers may be tempted to forgo the use of a torque wrench, relying instead on "feel." GF does not endorse this practice. Job-site studies have

shown that experienced installers are only slightly better than new trainees at estimating bolt torque by feel. A torque wrench is always recommended.

Never use an impact wrench to install a vinyl flange.

Installation

Checking System Alignment

Before assembling the flange, be sure that the two parts of the system being joined are properly aligned. GF has developed a "pinch test" that allows the installer to assess system alignment quickly and easily with minimal tools.

First check the gap between the flange faces by pinching the two mating components toward each other with one hand as shown below. If the faces can be made to touch, then the gap between them is acceptable.

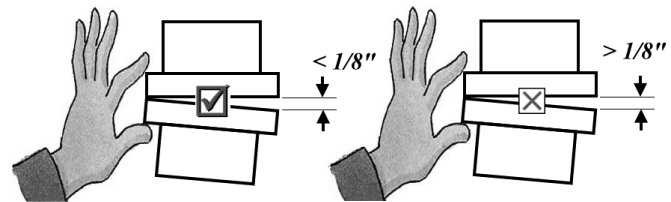

Next check the angle between the flange faces. If the faces are completely flush when pinched together, as shown above, then the alignment is perfect, and you may continue installation. Otherwise, pinch the faces together so that one side is touching, then measure the gap between the faces on the opposite side. The gap should be no more than 1/8".

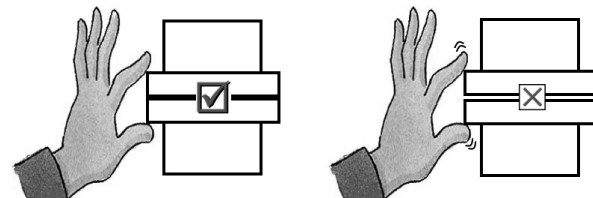

To assess high-low misalignment, pull the flange faces flush together. If the faces are concentric within 1/8", then the high-low misalignment is acceptable.

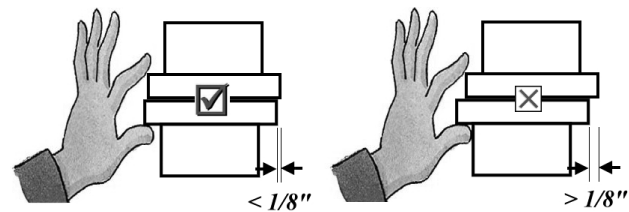

If the gap between the mating components can not be closed by pinching them with one hand, or if the angle

or high-low misalignment between them is too large, then using the bolts to force the components together will result in excessive stress and possible failure during or after installation. In this case, inspect the system to find the greatest source of misalignment and refit the system with proper alignment before bolting.

The pinch test is a good rule of thumb, but always use common sense as well. If it seems difficult or awkward to pull the flange faces together, then stop the installation and either refit the system or consult your GF representative before proceeding.

Bolt Hole Alignment

The bolt holes of a Van Stone flange will align automatically at the bolts are inserted and tightened. No additional adjustment is necessary.

To align the bolt holes of a fixed flange, use standard two-holing procedure.

Placing the Gasket

Center the gasket between the flange faces, with the bolt holes aligned with corresponding holes in the gasket. A full-face gasket cut to the specified dimensions (see Table 1) should come just to the inner edge of the flange face near the flow path, or overlap the edge slightly.

Inserting the Bolts

If using copper-graphite antiseize lubricant as recommended, apply the lubricant evenly with a brush directly to the bolt threads, and to the nut if desired. Cover the bolt from its tip to the maximum extent to which the nut will be threaded.

Insert bolts through washers and bolts holes as shown:

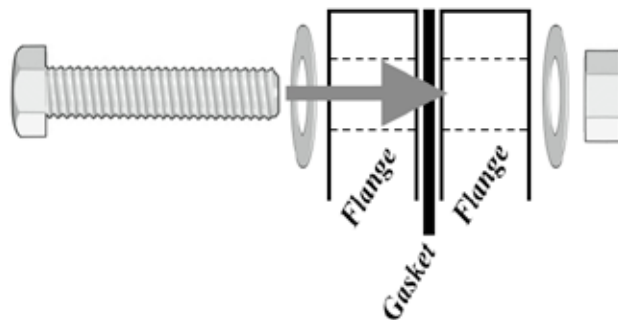

Tighten all nuts by hand. As you tighten each nut, the nuts on the other bolts will loosen slightly. Continue to hand-tighten all of the nuts until none remain loose.

Now the flange assembly will remain in place as you prepare to fully tighten it.

Again, when hand-tightened, at least two threads beyond the nut should be exposed in order to ensure permanent engagement. If less than two threads are exposed, disassemble the flange and use longer bolts.

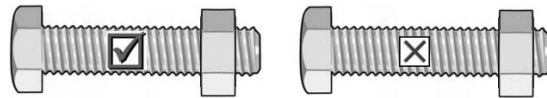

Tightening the Bolts

Vinyl flanges require gradual, even bolt tightening. Tightening one bolt to the maximum recommended torque while other bolts are only hand-tight, or tightening bolts in the wrong order, produces uneven stresses that may result in cracking or poor sealing.

To ensure even distribution of stresses in the fully-installed flange, tighten the bolts in a star pattern as described in ANSI B16.5:

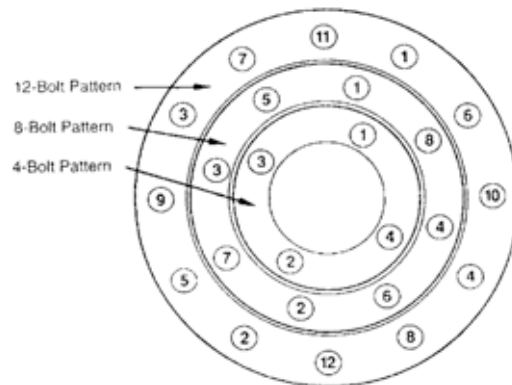

For the installer's convenience, the pattern is also indicated by numbers molded into the vinyl flange next to each bolt hole.

The torque required on each bolt in order to achieve the best seal with minimal mechanical stress has been carefully studied in laboratory and field installations, and is given in Table 3.

To ensure even distribution of stresses and a uniform seal, tighten the bolts to the first torque value in the sequence, using a star pattern, then repeat the star pattern while tightening to the next torque value, and so on up to the maximum torque value.

Vinyls, like all polymers, deform slightly under stress. A final tightening after 24 hours is recommended, when practical, to ensure that any bolts that have loosened due to relaxation of the polymer are fully engaged.

If a flange leaks when pressure-tested, retighten the bolts to the full recommended torque and retest. Do not exceed the recommended torque before consulting an engineer or GF representative.

Table 3

Multiple-Pass Bolt Torque

Size (in)	Torque Sequence (ft-lb, lubed*)				Torque Sequence (ft-lb, unlubed**)			
	1 st	2 nd	3 rd	4 th	1 st	2 nd	3 rd	4 th
1/2	3	5	-	-	5	8	-	-
3/4	3	5	-	-	5	8	-	-
1	3	5	-	-	5	8	-	-
1 1/4	3	5	-	-	5	8	-	-
1 1/2	3	5	-	-	5	8	-	-
2	5	8	-	-	5	10	12	-
2 1/2	5	8	10	-	10	15	18	-
3	5	12	15	-	15	20	25	-
4	10	15	20	-	15	25	32	-
6	12	24	30	-	20	32	42	-
8	15	35	40	-	30	40	50	60
10	25	50	60	-	20	40	60	70
12	30	60	72	-	20	50	65	80

* Assumes the use of SS, zinc- or cadmium-plated bolt and/or nut along with copper-graphite antiseize lubricant brushed directly onto the bolt threads.

** Assumes the use of zinc- or cadmium-plated bolt, nut, or both. Never use unlubricated, uncoated bolts and nuts with vinyl flanges, as high friction and seizing lead to unpredictable torque and a high incidence of cracking and poor sealing.

Note that the torques listed in Table 3 are for flange-to-flange connections in which the full faces of the flanges are in contact. For other types of connections, such as between a flange and a butterfly valve, where the full face of the flange is not in contact with the mating component, less torque will be required. Do not apply the maximum listed torque to the bolts in such connections, which may cause deformation or cracking, since the flange is not fully supported by the mating component. Instead, start with approximately two-thirds of the listed maximum torque and increase as necessary to make the system leak-free after pressure testing.

Documentation

Keep Instructions Available

Provide a copy of these instructions to every installer on the job site prior to beginning installation. Installers who have worked primarily with metal flanges often make critical mistakes when installing vinyl flanges. Even experienced vinyl installers will benefit from a quick review of good installation practices before starting a new job.

Installation Tags

Best practices include tagging each flange with

- installer’s initials
- installation date
- final torque value (e.g., “29.2-31.5”)
- confirmation of 24-hour torque check (“y” or “n”)

This information can be recorded on pre-printed stickers, as shown below, and placed on each flange immediately after installation.



Experience has shown that installation tags speed up the process of resolving system leaks and product failures, improve communication between the contractor and distributor or manufacturer, highlight training opportunities, and promote worker diligence.

Installing PVC and CPVC Unions and True Union Ball Valves

Please read all instructions before attempting to install unions or valves.

Introduction

Because unions and ball valves have similar, threaded nut connectors, these instructions have been written with both of these components in mind. GF unions and ball valves are designed to provide many years of service when installed properly.

As with any piping system component, unions and valves have particular considerations that must be kept in mind during installation in order to ensure best performance. Even experienced installers will benefit from reviewing these instructions before each installation.

Valve Support

Ball valves must be well-supported. Refer to the GF Engineering Handbook for detailed instructions on support installation. (<http://www.gfpiping.com>)

An unsupported or insufficiently-supported valve body will twist when opened and closed, subjecting the union connection to torque stress that may cause cracking or distortion and subsequent leakage.

System Alignment

The major contributor to union nut failures is misalignment. Uneven compression of the o-ring will cause leaks to occur. Union nuts can be damaged by the stress of holding a misaligned system together.

Sealing Mechanism

GF union connections use an o-ring as the sealing mechanism which is highly effective under relatively low tightening force.

Dirt and Debris

An often overlooked issue is the presence of dirt and debris on the o-ring or sealing surface. This will prevent proper o-ring sealing; if it is present on the nut or body threads, it will clog the threads and prevent proper tightening.

Installation

Understand and carefully follow these installation steps in order to ensure a seal that is sufficient to guard against leaks while avoiding excessive forces that can damage the union nut.

End Connectors

Always remove the union nut and end connectors from the ball valve for installation.

Make sure that you slide the union nut onto the pipe, with the threads facing the proper direction, BEFORE installing the end connector.

Solvent Cementing

Solvent cementing of pipe into the union or ball valve sockets should be done before the union nut connections are engaged. Be careful not to get any cement on the sealing surfaces, which can disrupt the seal and cause leaks. For best results, allow the cemented joint to properly cure prior to assembling the union nut connection, in order to avoid damaging the uncured joint.

O-Ring Placement

Once the cement has cured, ensure that the o-ring is securely seated in its groove. The o-ring should rest securely in place without adhesive or other aids.



Never use any foreign substance or object to hold the o-ring in place.

Union Connection

There should be no gap between the mating components, so that the threaded nut serves only to compress the o-ring thus creating the seal. However, a small gap (less than 1/8") between the mating components is acceptable.



Never use the union nuts to draw together any gaps between the mating faces of the components or to correct any system misalignment.

Hand-Tightening (All Sizes) (see Table 1)

The next step is to hand-tighten the union nut. With the o-ring in place, engage the nut with its mating threads and turn clockwise with one hand. Continue turning with moderate force until the nut no longer turns.

Be careful to use reasonable force when tightening the nut. Your grip should be firm but not aggressive. The nut should turn easily until it bottoms out and brings the mating faces into direct contact.

It is recommended that you place an indexing mark, with a permanent marker, on the union nut and body to identify the hand tight position.



Do not use any form of lubricant on the threads of the union nut.

Union and ball valve sizes 3/8" through 1½" should be sufficiently sealed after hand-tightening, for the hydrostatic pressure test of the system.

Optional Further Tightening (Sizes 2" to 4")

(see Table 1)

Based on experience, or system requirements, the installer may choose to turn the nut an additional 1/8 turn (approximately 45°) in order to ensure a better seal before hydrostatically pressure testing the system.

To do this, use a strap wrench to turn the nut 1/8 turn past the index mark applied after assembly.



Do not exceed 1/8 turn past the index mark.

Do not use any metallic tools. Tool marks on the union nut will void manufacturer's warranty.

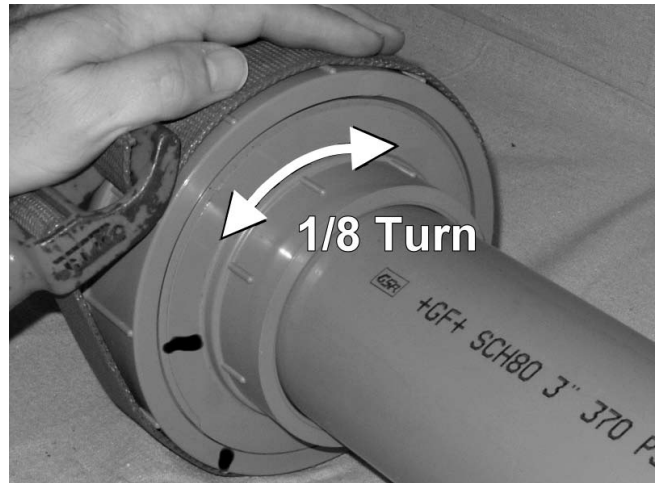

At this point, the system should be hydrostatically pressure tested before turning the union nut any farther.

Table 1
Tightening Guide for Union and Ball Valve Nuts

Size (in)	Initial	Additional, Pre-Test	Additional, Post-Test
3/8	Hand-Tight	None	1/8 Turn Max
1/2	Hand-Tight	None	1/8 Turn Max
3/4	Hand-Tight	None	1/8 Turn Max
1	Hand-Tight	None	1/8 Turn Max
1¼	Hand-Tight	None	1/8 Turn Max
1½	Hand-Tight	None	1/8 Turn Max
2	Hand-Tight	1/8 Turn Max	Consult Factory
2½	Hand-Tight	1/8 Turn Max	Consult Factory
3	Hand-Tight	1/8 Turn Max	Consult Factory
4	Hand-Tight	1/8 Turn Max	Consult Factory

Post-Test Tightening (Sizes 3/8” to 1½” only)
 (see Table 1)

It is highly unlikely that any union nut connection, when tightened as instructed above, will leak under normal operating conditions.

In the unlikely event that a leak occurs, the union nut at the leaking joint may be tightened an additional 1/8 turn, as described above. The system should then be re-tested.

If the joint still leaks after post-test tightening, do not continue to tighten the nut at the leaking joint. Disassemble the leaking joint, re-check system alignment, and check for obstructions in the sealing area.

If the cause of a leak can not be determined, or if you suspect that the union or valve is defective, contact your GF representative at (800) 854-4090 for further instructions.

Quality Check After Assembly

To check if the union connections are installed in a stress-free manner, GF recommends that a random check of alignment be done by removing the nut on selected union connection one at a time. A properly installed system will not have any movement of the piping as the nut is loosened. If any springing action is noticed, steps should be taken to remove the stress prior to re-installing the union nut.

Documentation

Keep Instructions Available

Provide a copy of these instructions to every installer on the job site prior to beginning installation.

Installation Tags

Best practices include tagging each union with:

- installer’s initials
- installation date

This information can be recorded on pre-printed stickers, as shown below, and placed on each union nut immediately after installation.

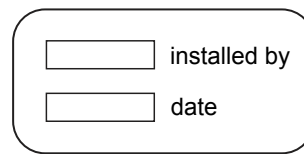

Experience has shown that installation tags speed up the process of resolving system leaks and product failures, improve communication between the contractor and distributor or manufacturer, highlight training opportunities, and promote worker diligence.

See the GF vinyl technical manual for information on guides, support spacing, and allowance for thermal expansion.

Above-Ground Installation

Support Spacing

When thermoplastic piping systems are installed above-ground, they must be properly supported to avoid unnecessary stresses and possible sagging.

Horizontal runs require the use of hangers as described on the next page, spaced approximately as indicated in the table below. Note that additional support is required as temperatures increase. Continuous support can be accomplished by the use of smooth structural angle or channel.

Where the pipe is exposed to impact damage, protective shields should be installed.

Tables are based on the maximum deflection of a uniformly loaded, continuously supported beam calculated from:

$$y = .00541 \frac{wL^4}{EI}$$

Where:

- y = Deflection or sag (in.)
- w = Weight per unit length (lb./in.)
- L = Support spacing (in.)
- E = Modulus of elasticity at given temperature (lb./in.²)
- I = Moment of inertia (in.⁴)

If 0.100 in. is chosen arbitrarily as the permissible sag (y) between supports, then:

$$L^4 = 18.48 \frac{EL}{w}$$

Where:

- w = Weight of pipe + weight of liquid (lb./in.)

$$\text{For a pipe } I = \frac{\pi}{64} (D_o^4 - D_i^4)$$

Where:

- D_o = Outside diameter of the pipe (in.)
- D_i = Inside diameter of the pipe (in.)

Then:

$$L = \left[.907 \frac{E}{W} (D_o^4 - D_i^4) \right]^{1/4}$$

$$= .976 \left[\frac{E}{W} D_o^4 - D_i^4 \right]^{1/4}$$

Recommended Support Spacing* (In Feet)

Nom. Pipe Size (In.)	PVC Pipe										CPVC Pipe					
	Schedule 40					Schedule 80					Schedule 80					
	Temp. °F					Temp. °F					Temp. °F					
	60	80	100	120	140	60	80	100	120	140	60	80	100	120	140	180
1/2	4 1/2	4 1/2	4	2 1/2	2 1/2	5	4 1/2	4 1/2	3	2 1/2	5 1/2	5 1/2	5	4 1/2	4 1/2	2 1/2
3/4	5	4 1/2	4	2 1/2	2 1/2	5 1/2	5	4 1/2	3	2 1/2	5 1/2	5 1/2	5 1/2	5	4 1/2	2 1/2
1	5 1/2	5	4 1/2	3	2 1/2	6	5 1/2	5	3 1/2	3	6	6	6	5 1/2	5	3
1 1/4	5 1/2	5 1/2	5	3	3	6	6	5 1/2	3 1/2	3	6 1/2	6 1/2	6	6	5 1/2	3
1 1/2	6	5 1/2	5	3 1/2	3	6 1/2	6	5 1/2	3 1/2	3 1/2	7	7	6 1/2	6	5 1/2	3 1/2
2	6	5 1/2	5	3 1/2	7	7	6 1/2	6	4	3 1/2	7	7	7	6 1/2	6	3 1/2
2 1/2	7	6 1/2	6	4	3 1/2	7 1/2	7 1/2	6 1/2	4 1/2	4	8	7 1/2	7 1/2	7 1/2	6 1/2	4
3	7	7	6	4	3 1/2	8	7 1/2	7	4 1/2	4	8	8	8	7 1/2	7	4
4	7 1/2	7	6 1/2	4 1/2	4	9	8 1/2	7 1/2	5	4 1/2	9	9	9	8 1/2	7 1/2	4 1/2
6	8 1/2	8	7 1/2	5	4 1/2	10	9 1/2	9	6	5	10	10 1/2	9 1/2	9	8	5
8	9	8 1/2	8	5	4 1/2	11	10 1/2	9 1/2	6 1/2	5 1/2	11	11	10 1/2	10	9	5 1/2
10	10	9	8 1/2	5 1/2	5	12	11	10	7	6	11 1/2	11 1/2	11	10 1/2	9 1/2	6
12	11 1/2	10 1/2	9 1/2	6 1/2	5 1/2	12	11	10	7	6	12 1/2	12 1/2	12 1/2	11	10 1/2	6 1/2
14	12	11	10	7	6	13 1/2	13	11	8	7						
16	12 1/2	11 1/2	10 1/2	7 1/2	6 1/2	14	13 1/2	11 1/2	8 1/2	7 1/2						

Note: This data is based on information supplied by the raw material manufacturers. It should be used as a general recommendation only and not as a guarantee of performance or longevity.

*Chart based on spacing for continuous spans and for uninsulated lines conveying fluids of specific gravity up to 1.00.

Hangers

There are many hangers and supports suitable for use in plastic piping systems, although some may require modification. It is important in a plastic piping system to provide a wide load-bearing surface and that any restraints recognize that vinyl piping systems are somewhat notch sensitive. Also, if the thermal movement of a plastic piping system might cause the pipeline to abrade on a rough surface, such as concrete, some means of isolating the pipe should be considered. Wear pads of plastic can be fashioned from the pipe or wooden isolators can be used.

It is also important to recognize the thermal movement in any plastic piping system and the hangers and support structures should allow for, or direct, the expansion that may be in a particular system. Pipe hangers must be carefully aligned and must have no rough or sharp edges that could contact and potentially damage the pipe. The hanger or support system should recognize the thermal expansion in a plastic pipe system and pipe should be allowed to move.

Vertical lines must also be supported at intervals so that the fittings at the lower end of a riser or column are not overloaded. The supports should not exert a compressive strain on the pipe, such as riser-type clamps that squeeze the pipe. A double bolt type, in conjunction with using a fitting shoulder, may afford the best method for supporting vertical systems.

Recommended Hangers for Plastic Piping Systems

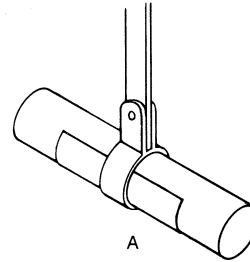

A
Band Hanger with Protective Sleeve

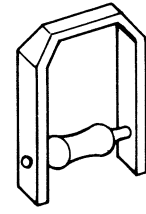

E
Roller Hanger

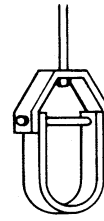

B
Clevis

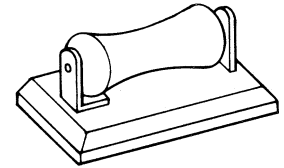

F
Pipe Roll and Plate



C
Adjustable Solid Ring Swivel Type

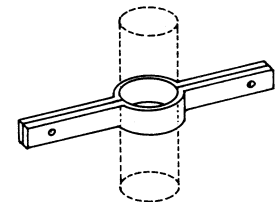

G
Riser Clamp

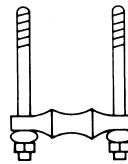

D
Single Pipe Roll

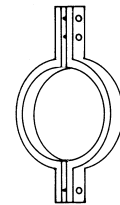

H
Double-Bolt Clamp

Continuous Support Arrangements

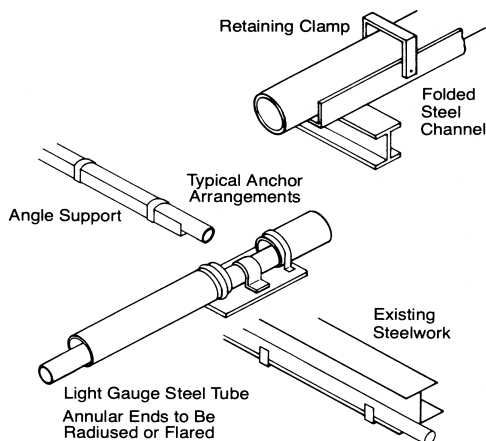

Typical Support Arrangements

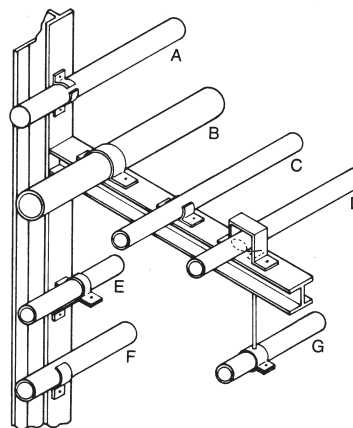

- A Pipe Clip (Vertical)
- B U-Type Clamp
- C Pipe Clip (Horizontal)
- D Roller Carrier
- E Angle Bracket with U-Clamp
- F Clamp (Vertical)
- G Suspended Ring Clamp

Note:
Pipes must be free to move axially

Anchors and Guides

Anchors in a piping system direct movement of pipe within a defined reference frame. At the anchoring point, there is no axial or transverse movement. Guides are used to allow axial movement of pipe but prevent transverse movement. Anchoring and guides should be engineered to provide the required function without point loading the plastic pipe.

Guides and anchors are used whenever expansion joints are used and are also on long runs and directional changes in piping.

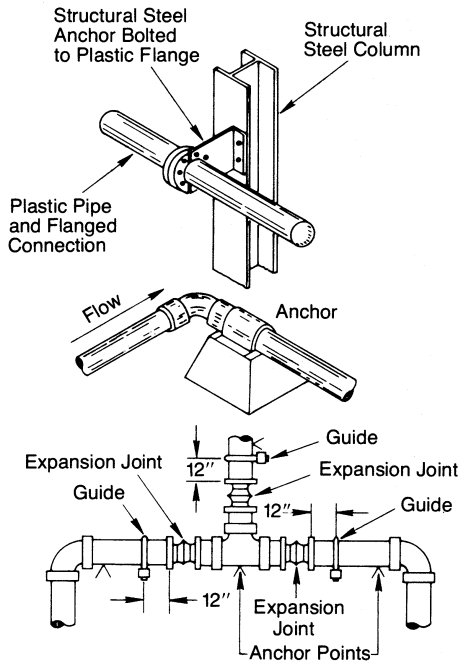

A Typical Method of Anchorage of a Change in Direction

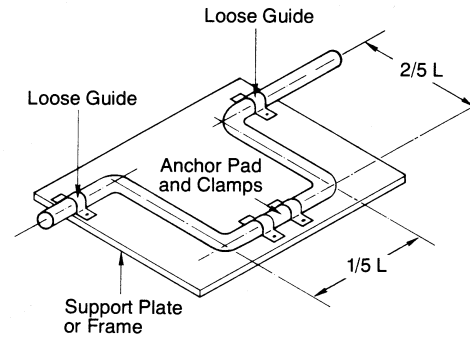

Typical Method of Anchorage

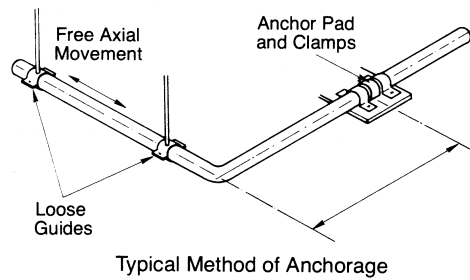

Sunlight and Plastics

Plastic pipe and fittings have been used extensively outdoors and are resistant to weathering, but may have some surface degradation from intense and prolonged exposure to the ultraviolet (UV) rays in sunlight. This degradation is a surface effect, reducing the impact rating but has no effect on the temperature capability as well as the chemical resistance or pressure rating of the pipe. This reduced impact rating can be eliminated by removal of the affected surface area and covering with a good bonding exterior latex paint.

The latex paint must be applied thick enough, probably several coats, to create an opaque covering. If the pipe and fittings are prepared properly for painting (cleaning and very light sanding), a good grade of exterior latex should last for many years. White or light colored pigment is suggested, which offers a more reflective surface.

Below-Ground Installation

Trenching and Bedding

1. Depth: When installing underground piping systems, the depth of the trench is determined by the intended service and by local conditions (as well as by local, state and national codes that may require a greater trench depth and cover than are technically necessary).

Underground pipes are subjected to external loads caused by the weight of the backfill material and by loads applied at the surface of the fill. These can range from static to dynamic loads.

Static loads comprise the weight of the soil above the top of the pipe plus any additional material that might be stacked above ground. An important point is that the load on a flexible pipe will be less than on a rigid pipe buried in the same manner. This is because the flexible conduit transfers part of the load to the surrounding soil and not the reverse. Soil loads are minimal with narrow trenches until a pipe depth of 10 feet is attained.

Dynamic loads are loads due to moving vehicles such as trucks, trains and other heavy equipment. For shallow burial conditions, live loads should be considered and added to static loads, but at depths greater than 10 feet, live loads have very little effect.

For static and dynamic soil loading tables, refer to specific materials sections, PVC and CPVC.

Pipe intended for potable water service should be buried at least 12 inches below the maximum expected frost penetration.

Soil Loads for PVC and CPVC Schedule 80 Pipe

Nom. Size	Wc' = Load Resistance of Pipe (lb./ft.)		H=Height of fill above pipe (ft.)	Wc = Soil Loads at Various Trench Widths at Top of Pipe (lb./ft.)			
	Schedule 80 Pipe			2 ft.	3 ft.	4 ft.	5 ft.
	E' = 200	E' = 700					
1½	1375	1561	10	106	125	136	152
			20	138	182	212	233
			30	144	207	254	314
			40	—	214	269	318
2	1161	1400	10	132	156	170	190
			20	172	227	265	291
			30	180	259	317	392
			40	—	267	337	398
2½	1593	1879	10	160	191	210	230
			20	204	273	321	352
			30	216	306	377	474
			40	—	323	408	482
3	1416	1772	10	196	231	252	280
			20	256	336	392	429
			30	266	266	384	469
			40	—	394	497	586
4	1266	1735	10	252	297	324	360
			20	328	432	540	551
			30	342	493	603	743
			40	—	506	639	754
6	1323	2028	10	371	437	477	530
			20	484	636	742	812
			30	503	725	888	1093
			40	—	745	941	1110
8	1319	2250	10	483	569	621	690
			20	630	828	966	1057
			30	656	945	1156	1423
			40	—	970	1225	1415
10	1481	2649	10	602	710	774	860
			20	785	1032	1204	1317
			30	817	1177	1405	1774
			40	—	1209	1527	1801
12	1676	3067	10	714	942	919	1020
			20	931	1225	1429	1562
			30	969	1397	1709	2104
			40	—	1434	1811	2136

Note 1: Figures are calculated from minimum soil resistance values (E' = 200 psi for uncompacted sandy clay foam) and compacted soil (E' = 700 for side-fill soil that is compacted to 90% or more of Proctor Density for distance of two pipe diameters on each side of the pipe). If Wc' is less than Wc at a given trench depth and width, then soil compaction will be necessary.

Note 2: These are soil loads only and do not include live loads.

Trench Widths

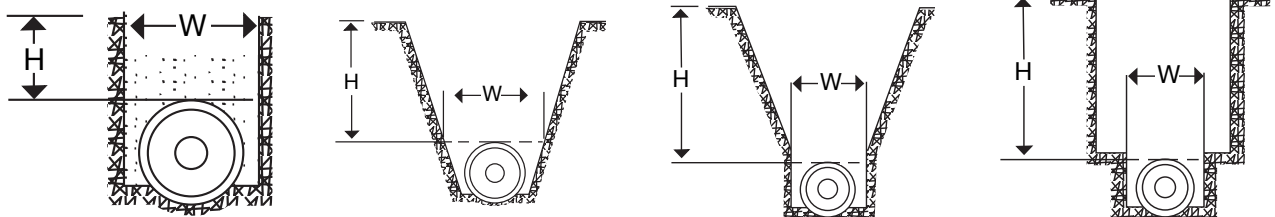

Note: W = Trench Width at Top of Pipe.

2. Bedding: The bottom of the trench should provide a firm, continuous bearing surface along the entire length of the pipe run. It should be relatively smooth and free of rocks. Where hardpan, ledge rock or boulders are present, it is recommended that the trench bottom be cushioned with at least four (4) inches of sand or compacted fine-grained soils.

3. Snaking: To compensate for thermal contraction, the snaking technique of offsetting the pipe with relation to the trench centerline is recommended.

The “Snaking Length” table below gives the required loop length, in feet, and offset in inches, for various temperature variations.

Snaking Length vs. Offset (in.) to Compensate for Thermal Contraction

Snaking Length, (ft.)	Maximum Temperature Variation (°F) Between Time of Cementing and Final Backfilling									
	10°	20°	30°	40°	50°	60°	70°	80°	90°	100°
	Loop Offset, (in.)									
20	2.5	3.5	4.5	5.20	5.75	6.25	6.75	7.25	7.75	8.00
50	6.5	9.0	11.0	12.75	14.25	15.50	17.00	18.00	19.25	20.25
100	13.0	18.0	22.0	26.00	29.00	31.50	35.00	37.00	40.00	42.00

Example: Snaking is particularly important when laying small diameter pipe in hot weather. For example, a 100-foot length of PVC Type I pipe will expand or contract about 3/4” for each 20°F temperature change. On a hot summer day, the direct rays of the sun on the pipe can drive the surface temperature up to 150°F. At night, the air temperature may drop to 70°F. In this hypothetical case, the pipe would undergo a temperature change of 80°F — and every 100 feet of pipe would contract 3”. This degree of contraction would put such a strain on newly cemented pipe joints that a poorly made joint might pull apart.

Installation: A practical and economical method is to cement the line together at the side of the trench during the normal working day. When the newly cemented joints have dried, the pipe is snaked from one side of the trench to the other in gentle, alternative curves. This added length will compensate for any contraction after the trench is backfilled (see “Snaking of Pipe Within Trench” illustration at right).

Snaking of Pipe Within Trench

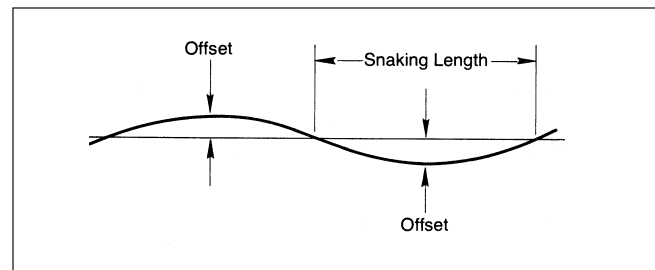

Snaking of thermoplastic pipe within trench to compensate for contraction.

Backfilling

Before making the final connections and backfilling, the pipeline should be cooled to near the temperature of the soil. During hot weather, for example, backfilling should be done early in the morning, when the solvent-cemented joints are completely dried and the line is fully contracted.

Assuming that the pipe is uniformly and continuously supported over its entire length on firm, stable material, it should first be covered with 6 to 8 inches of soil that is free of debris and rocks larger than one-half inch in diameter. This initial layer should be compacted by hand or, preferably, by mechanical tamper so that it acts as a protective cushion against the final backfill. Any large, sharp rocks that could penetrate the tamped layer around the pipe should be removed from the final backfill.

Heavy Traffic: When plastic pipe is installed beneath streets, railroads or other surfaces that are subjected to heavy traffic and resulting shock and vibration, it should be run within a protective metal or concrete casing.

Locating Buried Pipe: The location of plastic pipelines should be accurately recorded at the time of installation. Since pipe is a non-conductor, it does not respond to the electronic devices normally used to locate metal pipelines. However, a copper or galvanized wire can be spiraled around, taped to or laid alongside or just above the pipe during installation to permit the use of a locating device.

Note: For additional information, see ASTM D-2774, "Underground Installation of Thermoplastic Piping."

Anchors, Valves, and Other Connections

Plastic pipe is not designed to provide structural strength beyond sustaining internal pressures up to its designed hydrostatic pressure rating and normal soil loads. Anchors, valves and other connections must be independently supported to prevent added shearing and bending stresses on the pipe.

The above piping design rule applies also where pipe is brought out of the ground. Above-ground valves or other connections must be supported independently. If pipe is exposed to external damage, it should be protected with a separate, rigidly supported metal pipe sleeve at the danger areas. Thermoplastic pipe should not be brought above ground where it is exposed to high temperatures. Elevated temperatures can lower the pipe's pressure rating below design levels.

Standards

Standards allow an engineer to develop a specification which will provide accepted material and product performance. Having strong industry standards provides the market with the necessary criteria to determine the suitability of a specific material and/or product for a specific application. Within the plastics industry the primary source of these standards is ASTM which are usually the basis of most specifications.

Manufacturers may also subscribe to other standards, such as IAPMO, NSF, ANSI, ASME and UL. For the purposes of this manual we will restrict our listing of standards to those that are relevant to Schedule 80 PVC and CPVC.

ASTM (American Society for Testing and Materials)

D-1784: "Standard Specification for Rigid Poly(vinyl Chloride) (PVC) and Chlorinated Poly(Vinyl Chloride) (CPVC) Compounds"

This specification covers the compound materials physical requirements for PVC and CPVC pipe, valves and fittings based on several physical and chemical properties.

D-1785: "Standard Specification for Poly(Vinyl Chloride) (PVC) Plastic Pipe, Schedules 40, 80 and 120"

This specification covers poly(vinyl chloride) (PVC) pipe made in Schedule 40, 80 and 120 sizes and pressure-rated for water. Included are criteria for classifying PVC plastic pipe materials and PVC plastic pipe, a system of nomenclature for PVC plastic pipe and requirements and test methods for materials, workmanship, dimensions, sustained pressure, burst pressure, flattening, and extrusion quality.

D-2466: "Standard Specification for Poly(Vinyl Chloride) (PVC) Plastic Pipe Fittings, Schedule 40"

This specification covers poly(vinyl chloride) (PVC) Schedule 40 pipe fittings. Included are requirements for material, workmanship, dimensions, and burst pressure.

D-2467: "Standard Specification for Poly(Vinyl Chloride) (PVC) Plastic Pipe Fittings, Schedule 80"

This specification covers poly(vinyl chloride) (PVC) Schedule 80 pipe fittings. Included are requirements

for materials, workmanship, dimensions, and burst pressure.

D-2672: "Standard Specification for Joints for IPS PVC Pipe using Solvent Cement"

This specification covers the socket produced for solvent cements joints on both pressure and non-pressure IPS pipe. It also covers the testing of the joints on both pressure and non-pressure pipe, and includes requirements for socket dimensions, burst pressure, and joint tightness tests of the solvent cemented joints. The tests described are not intended for routine quality control, but rather to evaluate the performance characteristics of the joint.

D-2855: "Standard Practice for Making Solvent-Cemented Joints with Poly(Vinyl Chloride) (PVC) Pipe and Fittings"

This recommended practice describes, in detail, procedures for making solvent cemented joints. Preparation of the surfaces, applying the cement, making the assembly, handling after assembly, testing and a schedule of drying times related to temperature and pipe sizes are covered.

F-1498: "Standard Specification for Taper Pipe Threads 60° for Thermoplastic Pipe and Fittings"

This specification established requirements for dimensions and gauging of taper pipe threads used on threaded plastic pipe and fittings.

F-402: "Standard Practice for Safe Handling of Solvent Cements, Primers, and Cleaners Used for Joining Thermoplastic Pipe and Fittings"

This recommended practice covers procedures for the safe handling of solvent cements containing solvents which may be flammable, toxic or irritants. It recommends precautions and safeguards against the hazards of fire.

F-437: "Standard Specification for Threaded Chlorinated Poly(Vinyl Chloride) (CPVC) Plastic Pipe Fittings, Schedule 80"

This specification covers chlorinated poly(vinyl chloride) (CPVC) threaded Schedule 80 pipe fittings. Included are requirements for materials, workmanship, dimensions, and burst pressure.

F-439: “Standard Specification for Chlorinated Poly(Vinyl Chloride) (CPVC) Plastic Pipe Fittings, Schedule 80”

This specification covers chlorinated poly(vinyl chloride) (CPVC) Schedule 80 pipe fittings. Included are requirements for materials, workmanship, dimensions, and burst pressure.

F-441: “Standard Specification for Chlorinated Poly(Vinyl Chloride) (CPVC) Plastic Pipe, Schedules 40 and 80”

This specification covers chlorinated poly(vinyl chloride) (CPVC) pipe made in Schedule 40 and 80 sizes and pressure-rated for water. Included are criteria for classifying CPVC plastic pipe materials and CPVC plastic pipe, a system of nomenclature for CPVC materials, workmanship, dimensions, sustained pressure, burst pressure, flattening and extrusion quality. Methods of marking are also given.

ASME/ANSI (American Society of Mechanical Engineers / American National Standards Institute)

These standards were developed for metal pipe systems and some or all of the components have been adopted by the plastic piping industry. It is extremely important for the engineer or specifying influence to understand the scope of these standards and the extent to which plastic piping will conform.

B16.5: Flanges and Flanged Piping

In plastic piping systems, this standard is used to establish the flange O.D., bolt hole pattern and bolt hole size.

B1.20.1: National Pipe Thread Taper - Pipe Thread Dimensions

This is a dimensional specification covering standard tapered pipe threads, identified by GF Piping Systems as FPT (Female Pipe Thread) and MPT (Male Pipe Thread).

NSF/ANSI (National Sanitation Foundation / American National Standards Institute)

This company acts as the third-party certification agency for the plastics industry, as well as providing a certification regarding the acceptability of product for certain applications, such as potable water or chemical waste.

Standard 14: Plastic Piping Systems Components and Related Materials

This standard applies to inspection for compliance with all relevant industry standards. This primarily relates to ASTM but NSF will certify compliance with any standards the company publicly claims to meet.

Standard 61: Drinking Water Systems Components – Health Effects

This standard relates to the suitability of product in potable water systems.

Sample Specification

PVC Schedule 40 Pipe and Fittings

Scope: This sample specification covers the manufacturer's requirements for PVC Schedule 40 pipe and fittings manufactured of Rigid Poly (Vinyl chloride) (PVC). All pipe and fittings shall be as manufactured by Georg Fischer Piping Systems, Little Rock, Arkansas.

Materials: All materials shall be PVC type I, Grade I, meeting, or exceeding, the requirements of ASTM D-1784, cell classification 12454-B. All compound components shall be listed with NSF and meet the requirements of ANSI/NSF Standard 61 as suitable for Potable Water.

Pipe: All PVC Schedule 40 pipe shall meet, or exceed, the requirements of ASTM D-1785. Any pipe bells shall meet the requirements of ASTM D-2672. All piping shall be listed with NSF under Standards 14/61 and shall carry the NSF seal for suitability with Potable Water.

Fittings: All PVC Schedule 40 fittings shall meet, or exceed the requirements of ASTM D-2466 and shall be listed with NSF under standards 14/61. Product shall carry the NSF seal for suitability with Potable Water.

Installation: Installation and testing shall be in accordance with accepted engineering and installation practices as noted in the Georg Fischer Piping Systems Technical Manual as well as the solvent cement manufacturer's written instructions. To ensure compatibility all pipe, valves and fittings shall be manufactured and supplied by Georg Fischer Piping Systems.

******* CAUTION *******
Do not test with Air or Air over Water.



GEORG FISCHER
PIPING SYSTEMS

Sample Specification

PVC Schedule 80 Pipe and Fittings

Scope: This sample specification covers the manufacturer's requirements for PVC Schedule 80 pipe and fittings manufactured of Rigid Poly (Vinyl Chloride) (PVC). All pipe, valves and fittings shall be as manufactured and supplied by Georg Fischer Piping Systems, Little Rock, Arkansas.

Materials: All materials shall be PVC Type I, Grade I, with a cell classification of 12424-B, and shall meet, or exceed, the requirements of ASTM D-1784. All compound components shall be listed with NSF and meet the requirements of NSF Standard 61 as suitable for potable water.

Pipe: All PVC Schedule 80 pipe shall meet, or exceed, the requirements of ASTM D-1785. Any pipe bells shall meet the requirements of ASTM D-2672. All pipe shall be listed with NSF under Standards 14/61 and shall carry the NSF seal for Potable Water. Any threaded PVC 80 pipe shall meet the requirements of ANSI B1.20.1 and shall be accomplished with pipe dies specifically designed for use with plastic pipe.

Fittings:

Socket: All PVC Schedule 80 fittings shall meet, or exceed, the dimensional and tolerance requirements of ASTM D-2467

Threads: All PVC Schedule 80 threaded fittings shall meet, or exceed, the dimensional and tolerance requirements of ASTM D-2464

All fittings shall be listed with NSF under standards 14/61 and shall carry the NSF seal for Potable Water.

Valves: All valves shall be of compatible materials utilizing EPDM or FPM O-rings and seals with TFE seats. Valves shall be manufactured and supplied by Georg Fischer Piping Systems, Little Rock, AR.

Installation: Installation and testing shall be in accordance with accepted engineering and installation practices as noted in the Georg Fischer Piping Systems Technical Manual as well as the solvent cement manufacturer's written instructions. To ensure compatibility, all pipe, valves and fittings shall be manufactured and supplied by Georg Fischer Piping Systems.

******* CAUTION *******
Do not test with Air or Air over Water.



GEORG FISCHER
PIPING SYSTEMS

Sample Specification

CPVC Schedule 80 Pipe and Fittings

Scope: This specification covers the manufacturer's requirements for CPVC Schedule 80 24448 pipe and fittings manufactured of Rigid Chlorinated Poly (Vinyl Chloride) (CPVC). All pipe, valves and fittings shall be as manufactured and supplied by Georg Fischer Piping Systems.

Materials: All pipe materials shall be CPVC Type IV, Grade I, with a cell classification of 24448 per ASTM D1784. All fitting materials shall be CPVC with a cell classification of 23447 per ASTM D1784. All compound components shall be listed with NSF and meet the requirements of NSF Standard 61 as suitable for potable water.

Pipe: All CPVC Schedule 80 24448 pipe shall meet the requirements of ASTM F441. All pipes shall be listed with NSF under Standards 14/61 and shall carry the NSF seal for Potable Water. Any threaded CPVC 80 24448 pipe shall meet the requirements of ANSI B1.20.1 and threading shall be accomplished with pipe dies specifically designed for use with plastic pipe.

Fittings:

Socket: All CPVC Schedule 80 fittings shall meet requirements of ASTM F439.

Threaded: All CPVC Schedule 80 threaded fittings shall meet the requirements of ASTM F437.

All fittings shall be listed with NSF under standards 14/61 and shall carry the NSF seal for Potable Water.

Installation: Installation and testing shall be in accordance with accepted engineering and installation practices as noted in the Georg Fischer Piping Systems Technical Manual as well as the solvent cement manufacturer's written instructions. To ensure compatibility, all pipe, valves and fittings shall be manufactured and supplied by Georg Fischer Piping Systems.

******* CAUTION *******
Do not test with Air or Air over Water.



GEORG FISCHER
PIPING SYSTEMS

PVC IPS Schedule 40/80 Socket Dimensions

Size	Pipe O.D.	Entrance (A)		Bottom (B)		Max. out of round	Schedule 40 socket depth (C) (min.)	Schedule 80 socket depth (C) (min.)
		Max.	Min.	Max.	Min.			
1/4	0.540	0.556	0.548	0.540	0.532	0.016	0.500	0.625
3/8	0.675	0.691	0.683	0.675	0.667	0.016	0.594	0.750
1/2	0.840	0.852	0.844	0.840	0.832	0.016	0.688	0.875
3/4	1.050	1.062	1.054	1.050	1.042	0.020	0.719	1.000
1	1.315	1.330	1.320	1.315	1.305	0.020	0.875	1.125
1 1/4	1.660	1.675	1.665	1.660	1.650	0.024	0.938	1.250
1 1/2	1.900	1.918	1.906	1.900	1.888	0.024	1.094	1.375
2	2.375	2.393	2.381	2.375	2.363	0.024	1.156	1.500
2 1/2	2.875	2.896	2.882	2.875	2.861	0.030	1.750	1.750
3	3.500	3.524	3.508	3.500	3.484	0.030	1.875	1.875
3 1/2	4.000	4.024	4.008	4.000	3.984	0.030	2.000	
4	4.500	4.527	4.509	4.500	4.482	0.030	2.000	2.250
5	5.563	5.593	5.573	5.563	5.543	0.060	3.000	
6	6.625	6.658	6.636	6.625	6.603	0.060	3.000	3.000
8	8.625	8.670	8.640	8.625	8.595	0.090	4.000	4.000
10	10.750	10.795	10.765	10.750	10.720	0.100	5.000	5.000
12	12.750	12.795	12.765	12.750	12.720	0.120	6.000	6.000

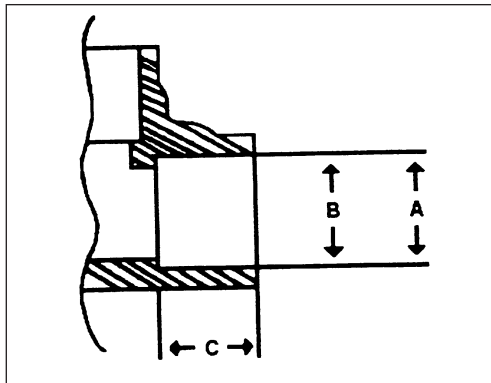

Weld Lines (Knit Lines) in Molded Fittings

Injection molding is the forcing of a viscous material, under pressure, to fill a space, forming a part. In the injection molding of fittings there are two basic components, a mold, which forms the outside of the part, and a core, which forms the inside of the part. The injection molding process forces the molten plastic material into this interstitial space where the material is cooled and then released. Inherent in this process, for most geometries, is the flowing together of the material and the development of a weld line.

The point where the plastic material is forced into the mold is termed the gate. The plastic material flows through this gate, and when it hits the core it will flow around it in both directions. At the point where the material flows back together there will usually be a line, termed a weld line or a knit line. This point of the material flowing back together is usually located about 180° from the gate and, since the weld line is visible on both the OD and ID, it can sometimes be thought to be a crack.

This knit line is a surface phenomenon and does not indicate a weakness or a defect in the part. Fittings are subject to some significant pressure tests, using ASTM Specifications, assuring the user of a quality molded component.



The melted plastic material is introduced to the mold and starts to flow around the core. Notice how the material tends to flow fairly evenly.



The plastic will continue to flow around the core.

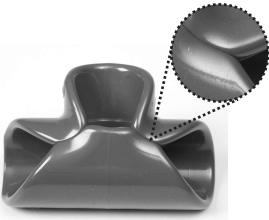

As the material flows together, a knit line starts to form. This knit line is fairly obvious at this point in the molding process.



However, as the mold cavity starts to fill, the material tends to flow together and the knit lines become less obvious.



When the mold is completely full, the knit lines are still there, as they are part of the process. This is just how the part is manufactured.

Conversion Charts

Decimal and Millimeter Equivalents of Fractions

Inches		Milli- meters	Inches		Milli- meters	Inches		Milli- meters	Inches		Milli- meters
Fractions	Decimals		Fractions	Decimals		Fractions	Decimals		Fractions	Decimals	
1/64	.015625	.397	17/64	.265625	6.747	33/64	.515625	13.097	49/64	.765625	19.447
1/32	.03125	.794	9/32	.28125	7.144	17/32	.53125	13.494	25/32	.78125	19.844
3/64	.046875	1.191	19/64	.296875	7.541	35/64	.546875	13.891	51/64	.796875	20.241
1/16	.0625	1.588	5/16	.3125	7.938	9/16	.5625	14.288	13/16	.8125	20.638
5/64	.078125	1.984	21/64	.328125	8.334	37/64	.578125	14.684	53/64	.828125	21.034
3/32	.09375	2.381	11/32	.34375	8.731	19/32	.59375	15.081	27/32	.83475	21.431
7/64	.109375	2.778	23/64	.359375	9.128	39/64	.609375	15.478	55/64	.859375	21.828
1/8	.125	3.175	3/8	.375	9.525	5/8	.625	15.875	7/8	.875	22.225
9/64	.140625	3.572	25/64	.390625	9.922	41/64	.640625	16.272	57/64	.890625	22.622
5/32	.15625	3.969	13/32	.40625	10.319	21/32	.65625	16.669	29/32	.90625	23.019
11/64	.171875	4.366	27/64	.421875	10.716	43/64	.671875	17.066	59/64	.921875	23.416
3/16	.1875	4.763	7/16	.4375	11.113	11/16	.6875	17.463	15/16	.9375	23.813
13/64	.203125	5.159	29/64	.453125	11.509	45/64	.703125	17.859	61/64	.953125	24.209
7/32	.21875	5.556	15/32	.46875	11.906	23/32	.71875	18.256	31/32	.96875	24.606
15/64	.234375	5.953	31/64	.484375	12.303	47/64	.734375	18.653	63/64	.984375	25.003
1/4	.250	6.350	1/2	.500	12.700	3/4	.750	19.050	1	1.000	25.400

Length Conversion

Units of Length	Multiply units in left column by proper factor below							
	in.	ft.	yd.	mile	mm	cm	m	km
1 inch	1	0.0833	0.0278	—	25.4	2.540	0.0254	—
1 foot	12	1	0.3333	—	304.8	30.48	0.3048	—
1 yard	36	3	1	—	914.4	91.44	0.9144	—
1 mile	—	5280	1760	1	—	—	1609.3	1.609
1 millimeter	0.0394	0.0033	—	—	1	0.100	0.001	—
1 centimeter	0.3937	0.0328	0.0109	—	10	1	0.01	—
1 meter	39.37	3.281	1.094	—	1000	100	1	0.001
1 kilometer	—	3281	1094	0.6214	—	—	1000	1

[1 micron = 0.001 millimeter]

Weight Conversion

Units of Weight	Multiply units in left column by proper factor below						
	grain	oz.	lb.	ton	gram	kg	metric ton
1 grain	1	—	—	—	0.0648	—	—
1 ounce	437.5	1	0.0625	—	28.35	0.0283	—
1 pound	7000	16	1	0.0005	453.6	0.4536	—
1 ton	—	32,000	2000	1	—	907.2	—
1 gram	15.43	0.0353	—	—	1	0.001	—
1 kilogram	—	35.27	2.205	—	1000	1	—
1 metric ton	—	35,274	2205	1.1023	—	1000	1

Density Conversion

Units of Density	Multiply units in left column by proper factor below				
	lb./in. ³	lb./ft. ³	lb./gal.	g/cm ³	g/liter
1 pound/in. ³	1	1728	231.0	27.68	27,680
1 pound/ft. ³	—	1	0.1337	0.0160	16.019
1 pound/gal.	0.00433	7.481	1	0.1198	119.83
1 gram/cm ³	0.0361	62.43	8.345	1	1000.0
1 gram/liter	—	0.0624	0.00835	0.001	1

Area Conversion

Units of Area	Multiply units in left column by proper factor below						
	in. ²	ft. ²	acre	mile ²	cm ²	m ²	hectare
1 inch ²	1	0.0069	—	—	6.452	—	—
1 foot ²	144	1	—	—	929.0	0.0929	—
1 acre	—	43,560	1	0.0016	—	4047	0.4047
1 mile ²	—	—	640	1	—	—	259.0
1 centimeter ²	0.1550	—	—	—	1	0.0001	—
1 meter ²	1550	10.76	—	—	10,000	1	—
1 hectare	—	—	2.471	—	1	10,000	1

Volume Conversion

Units of Volume	Multiply units in left column by proper factor below							
	in. ³	ft. ³	yd. ³	cm. ³	meter ³	liter	U.S. gal.	Imp. gal.
1 inch ³	1	—	—	16.387	—	0.0164	—	—
1 foot ³	1728	1	0.0370	28,317	0.0283	28.32	7.481	6.229
1 yard ³	46,656	27	1	—	0.7646	764.5	202.0	168.2
1 centimeter ³	0.0610	—	—	1	—	0.0010	—	—
1 meter ³	61,023	35.31	1.308	1,000,000	1	999.97	264.2	220.0
1 liter	61.025	0.0353	—	1000.028	0.0010	1	0.2642	0.2200
1 U.S. gallon	231	0.1337	—	3785.4	—	3.785	1	0.8327
1 Imp. gallon	277.4	0.1605	—	4546.1	—	4.546	1.201	1

Pressure Conversion

Units of Pressure	Multiply units in left column by proper factor below							
	lbs./in. ²	lb./ft. ²	Int. etc.	kg/cm ²	mm Hg at 32°F	in. Hg at 32°F	ft. water at 39.2°F	kPa
lb./in. ²	1	144	-	0.0703	51.713	2.0359	2.307	6.894
lb./ft. ²	0.00694	1	-	-	0.3591	0.01414	0.01602	0.04788
Int. etc.	14.696	2116.2	1	1.0333	760	29.921	33.90	-
kg/cm ²	14.223	2048.1	0.9678	1	735.56	28.958	32.81	98.066
mm Hg	0.0193	2.785	-	-	1	0.0394	0.0446	0.1333
in Hg	0.4912	70.73	0.0334	0.0345	25.400	1	1.133	3.386
ft H ₂ O	0.4335	62.42	-	0.0305	22.418	0.8826	1	2.988
kPa	0.00145	20.89	-	0.010169	7.5006	0.2953	0.3346	1

Temperature Conversion

°F	°C	°F	°C	°F	°C	°F	°C	°F	°C
-459.4	-273	1	-17.2	61	16.1	300	149	900	482
-450	-268	2	-16.7	62	16.7	310	154	910	488
-440	-262	3	-16.1	63	17.2	320	160	920	493
-430	-257	4	-15.6	64	17.8	330	166	930	499
-420	-251	5	-15	65	18.3	340	171	940	504
-410	-246	6	-14.4	66	18.9	350	177	950	510
-400	-240	7	-13.9	67	19.4	360	182	960	516
-390	-234	8	-13.3	68	20	370	188	970	521
-380	-229	9	-12.8	69	20.6	380	193	980	527
-370	-223	10	-12.2	70	21.1	390	199	990	532
-360	-218	11	-11.7	71	21.7	400	204	1000	538
-350	-212	12	-11.1	72	22.2	410	210	1020	549
-340	-207	13	-10.6	73	22.8	420	215	1040	560
-330	-201	14	-10	74	23.3	430	221	1060	571
-320	-196	15	-9.4	75	23.9	440	227	1080	582
-310	-190	16	-8.9	76	24.4	450	232	1100	593
-300	-184	17	-8.3	77	25	460	238	1120	604
-290	-179	18	-7.8	78	25.6	470	243	1140	616
-280	-173	19	-7.2	79	26.1	480	249	1160	627
-273	-169	20	-6.7	80	26.7	490	254	1180	638
-270	-168	21	-6.1	81	27.2	500	260	1200	649
-260	-162	22	-5.6	82	27.8	510	266	1220	660
-250	-157	23	-5	83	28.3	520	271	1240	671
-240	-151	24	-4.4	84	28.9	530	277	1260	682
-230	-146	25	-3.9	85	29.4	540	282	1280	693
-220	-140	26	-3.3	86	30	550	288	1300	704
-210	-134	27	-2.8	87	30.6	560	293	1350	732
-200	-129	28	-2.2	88	31.1	570	299	1400	760
-190	-123	29	-1.7	89	31.7	580	304	1450	788
-180	-118	30	-1.1	90	32.2	590	310	1500	816
-170	-112	31	-0.6	91	32.8	600	316	1550	843
-160	-107	32	0	92	33.3	610	321	1600	871
-150	-101	33	0.6	93	33.9	620	327	1650	899
-140	-96	34	1.1	94	34.4	630	332	1700	927
-130	-90	35	1.7	95	35	640	338	1750	954
-120	-84	36	2.2	96	35.6	650	343	1800	982
-110	-79	37	2.8	97	36.1	660	349	1850	1010
-100	-73	38	3.3	98	36.7	670	354	1900	1038
-90	-68	39	3.9	99	37.2	680	360	1950	1066
-80	-62	40	4.4	100	37.8	690	366	2000	1093
-70	-57	41	5	110	43	700	371	2050	1121
-60	-51	42	5.6	120	49	710	377	2100	1149
-50	-46	43	6.1	130	54	720	382	2150	1177
-40	-40	44	6.7	140	60	730	388	2200	1204
-30	-34	45	7.2	150	66	740	393	2250	1232
-20	-29	46	7.8	160	71	750	399	2300	1260
-10	-23	47	8.3	170	77	760	404	2350	1288
0	-17.8	48	8.9	180	82	770	410	2400	1316
		49	9.4	190	88	780	416	2450	1343
		50	10	200	92	790	421	2500	1371
		51	10.6	210	99	800	427	2550	1399
		52	11.1	212	100	810	432	2600	1427
		53	11.7	220	104	820	438	2650	1454
		54	12.2	230	110	830	443	2700	1482
		55	12.8	240	116	840	449	2750	1510
		56	13.3	250	121	850	454	2800	1538
		57	13.9	260	127	860	460	2850	1566
		58	14.4	270	132	870	466	2900	1593
		59	15	280	138	880	471	2950	1621
		60	15.6	290	143	890	477	3000	1649

GF Piping Systems → worldwide at home

Our sales companies and representatives ensure local customer support in over 100 countries.



7777 Sloane Drive, Little Rock, AR 72206
Tel. (501) 490-7777, Toll Free (800) 423-2686
Fax (501) 490-7100
e-mail: us.ps@georgfischer.com
www.gfpiping.com

Australia

Georg Fischer Pty Ltd
Riverwood NSW 2210 Australia
Phone +61(0)2 9502 8000
australia.ps@georgfischer.com
www.georgfischer.com.au

Austria

Georg Fischer
Rohrleitungssysteme GmbH
3130 Herzogenburg
Phone +43(0)2782 856 43-0
austria.ps@georgfischer.com
www.georgfischer.at

Belgium / Luxembourg

Georg Fischer NV/SA
1070 Bruxelles/Brüssel
Phone +32(0)2 556 40 20
be.ps@georgfischer.com
www.georgfischer.be

Brazil

Georg Fischer Ltda
04795-100 São Paulo
Phone +55(0)11 5687 1311
br.ps@georgfischer.com

Canada

Georg Fischer Piping Systems Ltd
Brampton, ON L6T 4E3
Phone +1(905) 792-8005
ca.ps@georgfischer.com
www.gfpiping.ca

China

Georg Fischer
Piping Systems Ltd Shanghai
Pudong, Shanghai 201319
Phone +86(0)21 58 13 33 33
china.ps@georgfischer.com
www.cn.piping.georgfischer.com

Denmark / Iceland

Georg Fischer A/S
2630 Taastrup
Phone +45 (0)70 22 19 75
info.dk.ps@georgfischer.com
www.georgfischer.dk

France

Georg Fischer SAS
95932 Roissy Charles de Gaulle Cedex
Phone +33(0)1 41 84 68 84
fr.ps@georgfischer.com
www.georgfischer.fr

Germany

Georg Fischer GmbH
73095 Albershausen
Phone +49(0)7161 302-0
info.de.ps@georgfischer.com
www.georgfischer.de

India

Georg Fischer Piping Systems Ltd
400 076 Mumbai
Phone +91 224007 2001
in.ps@georgfischer.com
www.georgfischer.in

Italy

Georg Fischer S.p.A.
20063 Cernusco S/N (MI)
Phone +3902 921 861
it.ps@georgfischer.com
www.georgfischer.it

Japan

Georg Fischer Ltd
556-0011 Osaka,
Phone +81(0)6 6635 2691
jp.ps@georgfischer.com
www.georgfischer.jp

Korea

Georg Fischer Piping Systems
Guro-3 dong, Guro-gu, Seoul, Korea
Phone +82(0)2 2081 1450
Fax +82(0)2 2081 1453
kor.ps@georgfischer.com

Malaysia

Georg Fischer (M) Sdn. Bhd.
40460 Shah Alam, Selangor
Phone +60 (0)3 5122 5585
conne.kong@georgfischer.com

Mexico

Georg Fischer S.A. de C.V.
Apodaca, Nuevo Leon
CP66636 Mexico
Phone +52 (81)1340 8586
Fax +52 (81)1522 8906

Middle East

Georg Fischer Piping Systems
Dubai, United Arab Emirates
Phone +971 4 289 49 60
info.export@georgfischer.com
www.export.georgfischer.com

Netherlands

Georg Fischer N.V.
8161 PA Epe
Phone +31(0)578 678 222
nl.ps@georgfischer.com
www.georgfischer.nl

Norway

Georg Fischer AS
1351 Rud
Phone +47(0)67 18 29 00
no.ps@georgfischer.com
www.georgfischer.no

Poland

Georg Fischer Sp. z o.o.
02-226 Warszawa
Phone +48(0)22 313 10 50
poland.ps@georgfischer.com
www.georgfischer.pl

Romania

Georg Fischer
Piping Systems Ltd
020257 Bucharest - Sector 2
Phone +40(0)21 230 53 80
ro.ps@georgfischer.com
www.export.georgfischer.com

Russia

Georg Fischer Piping Systems
Moscow 125047
Tel. +7 495 258 60 80
ru.ps@georgfischer.com
www.georgfischer.ru

Singapore

Georg Fischer Pte Ltd
528 872 Singapore
Phone +65(0)67 47 06 11
sgp.ps@georgfischer.com
www.georgfischer.com.sg

Spain / Portugal

Georg Fischer S.A.
28046 Madrid
Phone +34(0)91 781 98 90
es.ps@georgfischer.com
www.georgfischer.es

Sweden / Finland

Georg Fischer AB
12523 Älvsjö-Stockholm
Phone +46(0)8 506 775 00
info.se.ps@georgfischer.com
www.georgfischer.se

Switzerland

Georg Fischer
Rohrleitungssysteme (Schweiz) AG
8201 Schaffhausen
Phone +41(0)52 631 30 26
ch.ps@georgfischer.com
www.piping.georgfischer.ch

Taiwan

Georg Fischer Piping Systems
San Chung City, Taipei Hsien
Phone +886 2 8512 2822
Fax +886 2 8512 2823

United Kingdom / Ireland

Georg Fischer Sales Limited
Coventry, CV2 2ST
Phone +44(0)2476 535 535
uk.ps@georgfischer.com
www.georgfischer.co.uk

USA / Latin America / Caribbean

Georg Fischer LLC
Tustin, CA 92780-7258
Phone +1(714) 731 88 00
Toll Free 800 854 40 90
us.ps@georgfischer.com
www.us.piping.georgfischer.com