

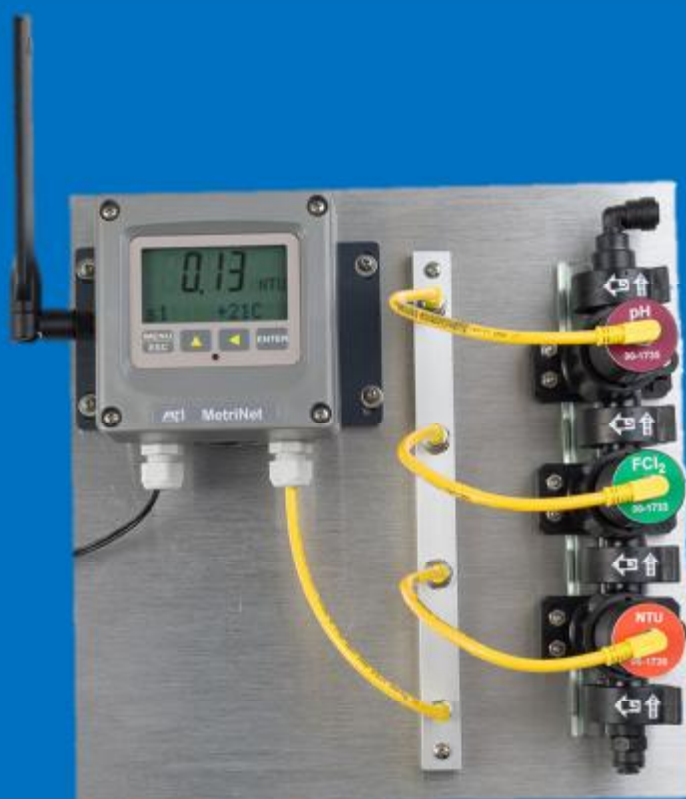

O & M Manual



MetriNet Controller

Home Office

Analytical Technology, Inc.
6 Iron Bridge Drive
Collegeville, PA 19426
Phone: 800-959-0299
610-917-0991
Fax: 610-917-0992
Email: sales@analyticaltechnology.com
Web: www.Analyticaltechnology.com

European Office

ATI (UK) Limited
Unit 1 & 2 Gatehead Business Park
Delph New Road, Delph
Saddleworth OL3 5DE
Phone: +44 (0)1457-873-318
Fax: + 44 (0)1457-874-468
Email: sales@atiuk.com

Table of Contents

<p>PART 1 - INTRODUCTION4</p> <p> 1.1 GENERAL 4</p> <p> 1.2 SYSTEM COMPONENTS 5</p> <p>PART 2 - SPECIFICATIONS7</p> <p> 2.1 METRINET CONTROLLER (Q52) 7</p> <p> 2.1 METRINET PERFORMANCE SPECIFICATIONS (Q52) .. 8</p> <p> 2.2 METRINET FLOW CHAMBERS 8</p> <p> 2.3 METRINET BUS BAR 8</p> <p>PART 3 - INSTALLATION9</p> <p> 3.1 SYSTEM MOUNTING 9</p> <p> 3.2 CONTROLLER MOUNTING 11</p> <p> 3.3 WALL OR PIPE MOUNT 12</p> <p> 3.4 FLOW SYSTEM MOUNTING 13</p> <p> 3.5 BUS BAR MOUNTING 14</p> <p> 3.6 SAMPLE CONNECTION 15</p> <p> 3.7 INTERMITTENT SAMPLING 16</p> <p> 3.8 ELECTRICAL CONNECTIONS 16</p> <p> 3.9 POWER CONSUMPTION 17</p> <p> 3.10 M-NODE PREPARATION 18</p> <p> 3.11 NODE INSTALLATION 18</p> <p>PART 4 – OPERATION19</p> <p> 4.1 GENERAL 19</p> <p> 4.2 CONTROLLER INTERFACE 19</p> <p> 4.3 M-NODE ASSIGNMENT 20</p> <p> 4.4 CONTROLLER PROGRAMMING 20</p> <p> 4.41 <i>MEASURE Menu</i> 22</p> <p> 4.42 <i>INFO Menu</i> 22</p> <p> 4.43 <i>SENSOR Menu</i> 23</p> <p> 4.44 <i>CONFIG Menu</i> 24</p> <p> 4.45 <i>OPTIONS Menu</i> 25</p> <p> 4.5 SET PASSWORDS 26</p> <p> 4.6 SENSOR DISPLAY 27</p> <p>PART 5 – DATA, ALARM & EVENT LOG28</p> <p> 5.1 GENERAL 28</p> <p> 5.2 DATA FILE FORMAT 28</p> <p> 5.3 ALARM FILE FORMAT 29</p> <p> 5.4 EVENT FILE FORMAT 29</p> <p> 5.5 SD RAM CARD 29</p> <p> 5.6 DATA STORAGE CAPACITY 30</p> <p>PART 6 – CYCLE MODE31</p> <p> 6.1 GENERAL 31</p>	<p> 6.2 POWER SEQUENCE 31</p> <p> 6.3 VALVE DELAY 31</p> <p> 6.4 DIGITAL INPUT 32</p> <p> 6.5 DIGITAL OUTPUT 32</p> <p>PART 7 – M-NODES 33</p> <p> 7.1 GENERAL 33</p> <p> 7.2 FREE CHORINE M-NODE 33</p> <p> 7.21 <i>Free Chlorine Span Calibration</i> 34</p> <p> 7.22 <i>Free Chlorine Zero Calibration</i> 35</p> <p> 7.23 <i>Free Chlorine Maintenance</i> 35</p> <p> 7.3 CONDUCTIVITY M-NODE 36</p> <p> 7.31 <i>Zero Adjustment</i> 36</p> <p> 7.32 <i>Conductivity Calibration</i> 36</p> <p> 7.33 <i>Conductivity Maintenance</i> 37</p> <p> 7.4 pH M-NODE 38</p> <p> 7.41 <i>pH Calibration</i> 38</p> <p> 7.42 <i>pH Maintenance</i> 38</p> <p> 7.43 <i>pH Sensor Cleaning</i> 40</p> <p> 7.5 COMBINED CHORINE M-NODE 41</p> <p> 7.51 <i>Chlorine Span Calibration</i> 42</p> <p> 7.52 <i>Chlorine Zero Calibration</i> 42</p> <p> 7.53 <i>Chlorine Maintenance</i> 43</p> <p> 7.6 ORP M-NODE 44</p> <p> 7.61 <i>ORP Calibration</i> 44</p> <p> 7.62 <i>ORP Maintenance</i> 45</p> <p> 7.63 <i>ORP Sensor Cleaning</i> 46</p> <p> 7.7 TURBIDITY M-NODE 47</p> <p> 7.71 <i>Turbidity Span Calibration</i> 47</p> <p> 7.72 <i>Turbidity Zero Calibration</i> 48</p> <p> 7.73 <i>Turbidity Maintenance</i> 48</p> <p> 7.8 DISSOLVED OXYGEN M-NODE 49</p> <p> 7.81 <i>D.O. Span Calibration</i> 50</p> <p> 7.82 <i>D.O. Zero Calibration</i> 52</p> <p> 7.83 <i>D.O. Maintenance</i> 52</p> <p> 7.9 TOTAL CHLORINE M-NODE 53</p> <p> 7.91 <i>Chlorine Span Calibration</i> 54</p> <p> 7.92 <i>Chlorine Zero Calibration</i> 54</p> <p> 7.93 <i>Chlorine Maintenance</i> 55</p> <p> 7.10 FLUORIDE M-NODE 56</p> <p> 7.101 <i>Fluoride Calibration</i> 56</p> <p> 7.102 <i>Fluoride Maintenance</i> 57</p> <p> 7.11 <i>Pressure M-Node</i> 59</p> <p>SPARE PARTS 60</p>
---	---

TABLE OF FIGURES

FIGURE 1 – METRINET SYSTEM WITH 3 M-NODES	5
FIGURE 2 – UP TO 4 NODE SYSTEM PANEL	9
FIGURE 3 – 5 - 8 NODE SYSTEM PANEL	10
FIGURE 4 - ENCLOSURE DIMENSIONS	11
FIGURE 5 - WALL MOUNT.....	12
FIGURE 6 – PIPE MOUNT	12
FIGURE 7 – DISCONNECTED FLOW CHAMBERS	13
FIGURE 8 – FLOW CHAMBER DIMENSIONS.....	14
FIGURE 9 - SENSOR COMMUNICATION INTERFACE	14
FIGURE 10 – TYPICAL INSTALLATION SAMPLE CONNECTION.....	15
FIGURE 11 – EXTERNAL CONNECTIONS	17
FIGURE 12 – METRINET CONTROLLER INTERFACE.....	19
FIGURE 13 – CONTROLLER SOFTWARE MAP	21
FIGURE 14 – RAW DATA FORMAT	28
FIGURE 15 – MICRO-SD CARD WITH ADAPTER	30
FIGURE 16 – CYCLE MODE SCHEMATIC	31
FIGURE 17 – CHLORINE M-NODE ASSEMBLY.....	33
FIGURE 18 – CHLORINE SENSOR EXPLODED VIEW	33
FIGURE 19 – PH SENSOR REFERENCE ASSEMBLY	39
FIGURE 20 – CHLORINE SENSOR EXPLODED VIEW	41
FIGURE 21 – ORP SENSOR REFERENCE ASSEMBLY	45
FIGURE 22 – D.O. SENSOR EXPLODED VIEW	49
FIGURE 23 – D.O. SATURATION TABLE	51
FIGURE 24 - TCL2 SENSOR EXPLODED VIEW	53
FIGURE 25 – FLUORIDE NODE EXPLODED VIEW.....	58
FIGURE 26 - PRESSURE SENSOR.....	59

Part 1 - Introduction

1.1 General

The MetriNet is an integrated water quality system designed for potable water distribution monitoring. The primary function is to log water quality measurements. Data may be manually collected using an SD card built into each controller. Interface options are also available to retrieve data from the unit via Modbus RTU/RS-485, Modbus TCP or Ethernet IP. With the Cell Modem option, periodic transmission of data to a user specified data storage location (cloud site) provides remote data collection.

MetriNet is a modular system consisting of a controller (Q52) and at least one sensing node (M-Node or Q32). Controllers may be connected to up to 8 M-Nodes using bus bars to consolidate communication signals. Currently available M-Nodes are as follows:

<u>Parameter</u>	<u>Range</u>	<u>Resolution</u>
Free Chlorine	0-5.00 ppm	0.01 ppm
Combined Chlorine	0-5.00 ppm	0.01 ppm
Total Chlorine	0-5.00 ppm	0.01 ppm
Turbidity	0-40.00 NTU	0.01 NTU
pH	0-14.00 pH	0.01 pH
Conductivity	0-2000 μ S	1 μ S
ORP	0-1000 mv.	1 mv.
Dissolved Oxygen	0-20.00 ppm	0.01 ppm
Fluoride	0.1-10.00 ppm	0.01 ppm
Dissolved Ozone	0-5.00 ppm	0.01 ppm
Chlorine Dioxide	0-5.00 ppm	0.01 ppm
Peracetic Acid	0-200 ppm	1 ppm
Hydrogen Peroxide	0-20.00 ppm	0.01 ppm
Pressure	0-300 PSI	1 PSIG

MetriNet systems are powered by either battery packs or local 12-24 VDC power supplies. The power source must be specified when ordering. A controller designed for battery operation should not be used on an external DC power supply. Units supplied for 12-24 VDC operation may be run from a battery pack but will draw more current than a unit designed strictly for battery power.

The MetriNet controller communicates with sensor nodes using the Modbus protocol. Each measuring node is a complete sensor and Modbus transmitter with submersible multi-pin connector on the back. If only one sensor is used, that sensor is connected directly to the controller.

If more than one sensor is used, sensors plug into a multi-sensor bus bar, which is then connected to the controller. Systems with more than 5 sensors require 2 bus bars. Bus bar connectors are protected by push-on vinyl protective caps. Leave caps in place for any connectors not in use.

M-Nodes are installed in modular flow chambers, secured with twist-lock pins on the front of the node. Each node requires one chamber and chambers clamp together with locking rings on each end. Push-to-connect fittings are installed on each end but end fittings contain 1/8" NPT female threads to accommodate other fittings. The outlet side of the flow assembly will normally contain a fixed-flow regulator to maintain a constant flow of 200 ml/min. when sample line pressure is 1-100 PSI (.07-6.6 bar). Maximum pressure on flow chambers should not exceed 100 PSI. Recommended inlet pressure is 15-60 PSI (1-4 bar).

In operation, MetriNet controllers log measurement data at an interval programmed by the user, from a minimum of every 0.1 minute to a maximum of 99.9 minutes. Data is stored in on-board non-volatile memory which may be written to an internal SD card. If the controller contains the optional modem, data is transmitted to a cloud based data site.



Figure 1 – MetriNet System with 3 M-Nodes

1.2 System Components

MetriNet systems are supplied in one of two ways, either as an assembled panel similar to that shown in Figure 1 or in individual components that can be mounted in an arrangement that better suits a specific application. Sensor nodes will normally not be installed in the flow chambers when packed for shipment as many sensors require preparation and/or calibration prior to use.

When unpacking the MetriNet hardware, check to verify that all items listed on the packing list have been received. Contact ATI if any discrepancies are noted. Each sensor node is marked with a part number and measurement designation on a label under the connector.



Flow Chamber Assembly



Typical M-Node



MetriNet Controller

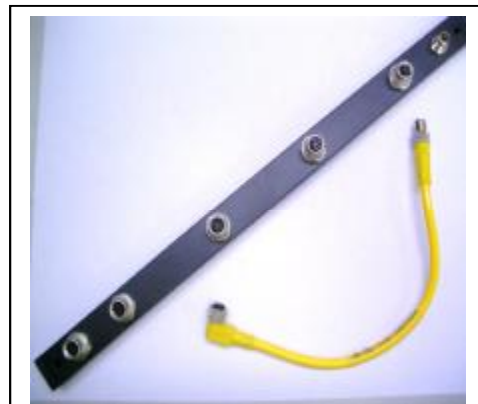

Bus Bar & Sensor Cables

Part 2 - Specifications

2.1 MetriNet Controller (Q52)

Displayed Parameters (for each M-Node)	Four digit node measurement (ppm, NTU, mv. etc) Sensor temperature, -10.0 to 55.0 °C (14 to 131 °F) Other measurement displays on lower line dependent on specific sensor
Display	0.75" (19.1 mm) high 4-digit main display with sign 12-digit secondary display, 0.3" (7.6 mm) 5x7 dot matrix.
Data Logger	Internal 4MB SPI Flash memory with micro SD card
Controls	4-key polycarbonate keypad, UV resistant coating
Power	12 VDC Line Version -Isolated, 12-24 VDC, 43 mA + 3 mA/Node Max. 12 VDC Battery version -Non-Isolated, 12V DC nom (8-16 VDC) 26 mA + 3 mA/Node Max.
Bus or Node Connection	Data cable with M8 waterproof connector, 13 ft. (4 m)
Ambient Temperature	Controller Service, -20 to 60 °C (-4 to 140 °F) Sensor Node Service, -5 to 55°C (23 to 131 °F) Storage, -5 to 70 °C (23 to 158 °F)
Ambient Humidity	0 to 95%, indoor/outdoor use, non-condensing to rated ambient temperature range
Electrical Certification	Ordinary Location approval pending. Pollution degree 2, installation category 2. CE to EN 61326-1
Environmental	RoHS Compliant
EMI/RFI Influence	Designed to EN 61326-1
Optional Modem	Cellular GSM/GPRS, 3G, 4G/LTE, CAT-M1. ATI supplied Aeris SIM card is standard.
Option Host Interface	Modbus RTU/RS-485, Modbus TCP, Ethernet IP
Enclosure	NEMA 4X, polycarbonate, stainless steel hardware HWD: 4.4" (112 mm) x 4.4" (112 mm) x 3.5" (89 mm)
Conduit Openings	Two PG-9 cable glands, one ½" NPT 2-hole cable gland.
Mounting Options	Wall or pipe mount bracket standard. Bracket suitable for either 1.5" or 2" I.D. U-Bolts for pipe mounting.
Weight	1 lb. (0.45 kg)

2.1 MetriNet Performance Specifications (Q52)

Accuracy	1% of range
Repeatability	0.5% of range
Sensitivity	0.1% of range
Non-Linearity	0.1% of range
Warm-up Time	3 seconds to rated performance (electronics only)
Supply Voltage Effects	+/- 0.05% of range

2.2 MetriNet Flow Chambers

Sample Pressure	5-60 PSI recommended, 100 PSI Max.
Material	Glass filled Ryton® (polyphenylene sulfide)
O-ring	Ethylene-propylene (EP)
Inlet	1/8" FNPT with 1/4" O.D. push-connect tube fitting
Outlet	1/8" FNPT with 1/4" O.D. push-connect right angle tube fitting.
Flow Control Option	200 ml/min. flow control element installed in outlet assembly.
Mounting	DIN rail adapter on bottom for 35 x 7.5 mm rail

2.3 MetriNet Bus Bar

Material	Powder coated aluminum
Connectors	Six M8 connectors, 5 female, 1 male (connections for 5 nodes and 1 controller)
Size	12" x 1/2" x 1/2" (30 x 12 x 12 mm)
Rating:	IP-67 when all connections made or capped



Equipment bearing this marking may not be discarded by traditional methods in the European community after August 12 2005 per EU Directive 2002/96/EC. End users must return old equipment to the manufacturer for proper disposal.

Part 3 - Installation

3.1 System Mounting

If your MetriNet system was purchased as a complete assembly mounted on a non-metallic plate, all that's needed is to mount the plate. Systems with up to 4 Nodes are supplied on a 14" x 14" plate, 1/4" thick. Mounting holes are located in each corner as shown below. Larger systems are generally custom sizes with dimensions provided separately. For systems of 5-8 sensors, a 20" x 14" plate is available as shown in Figure 3 on the next page.

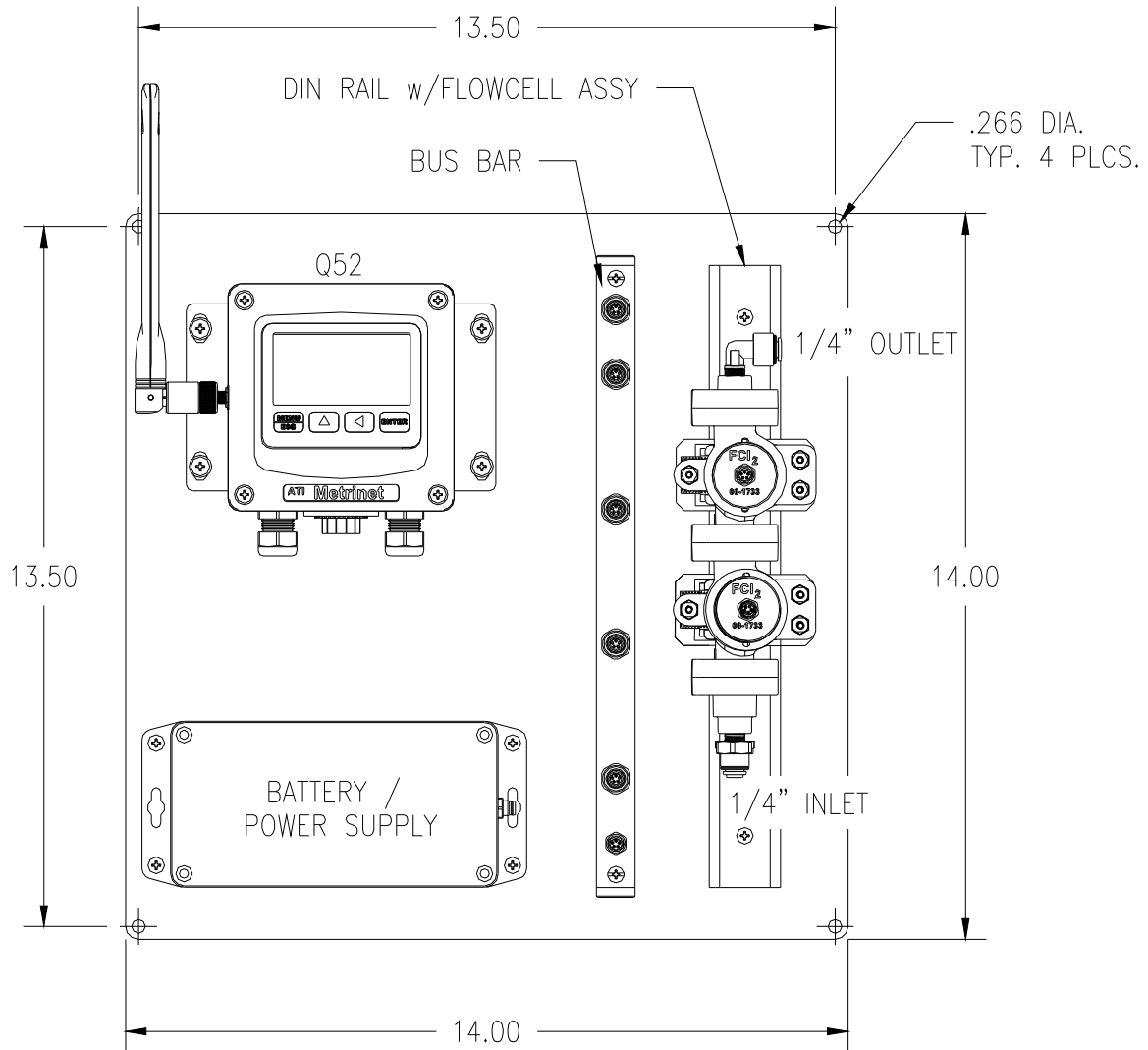

Figure 2 – up to 4 Node System Panel

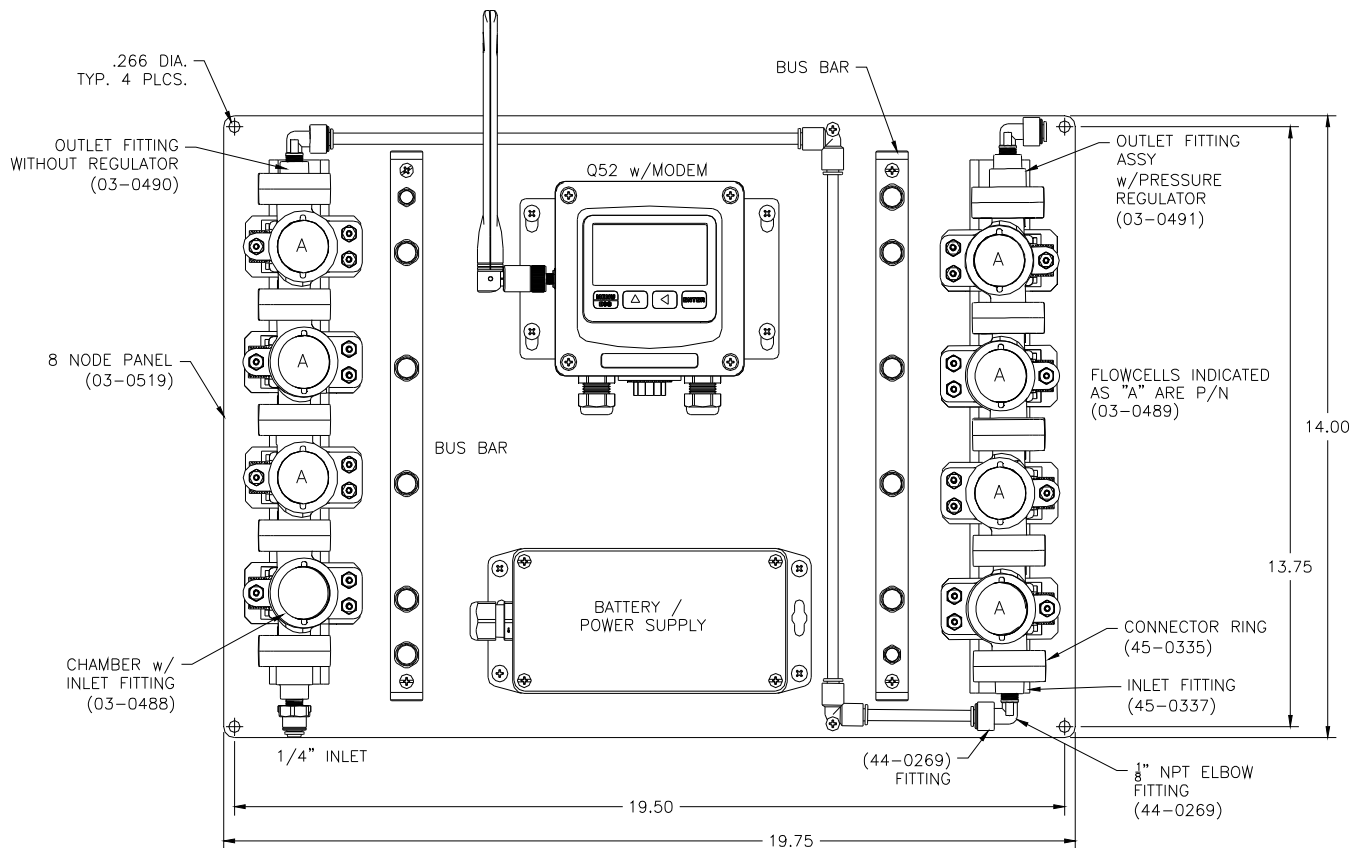

Figure 3-5 - 8 Node System Panel

3.2 Controller Mounting

MetriNet controllers are supplied with a PVC mounting plate that attaches to the back of the enclosure.

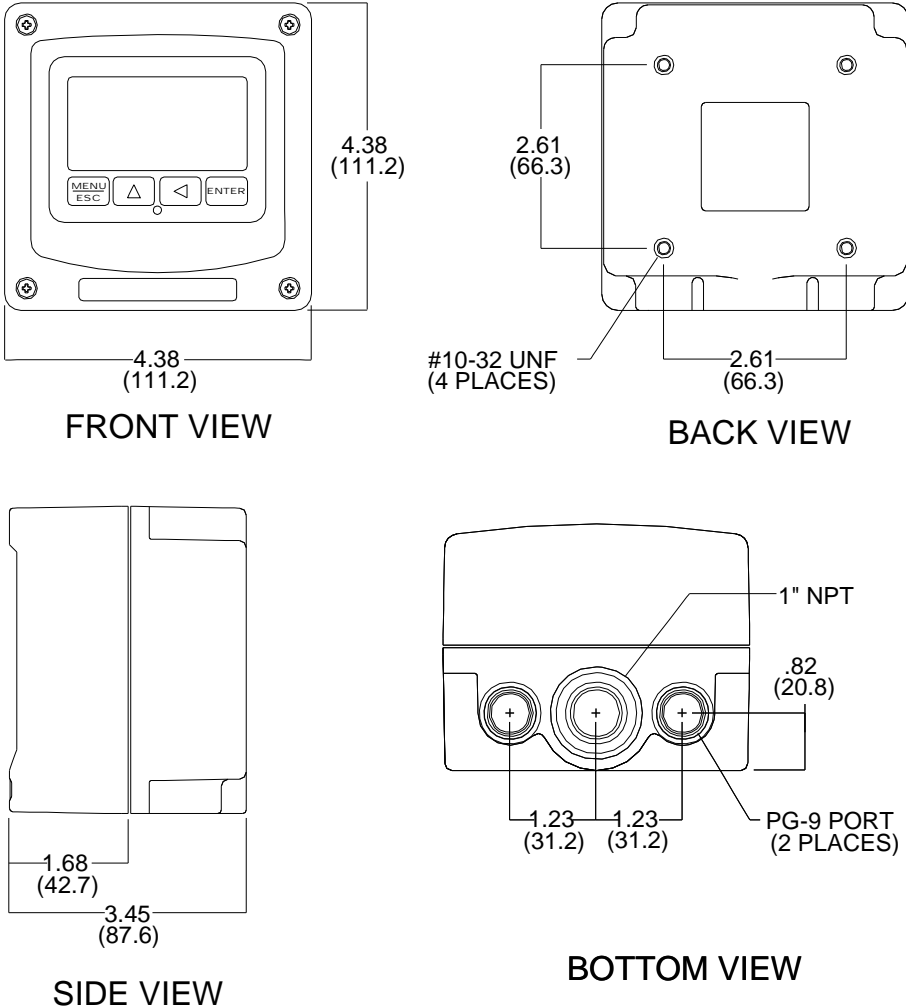

Figure 4 - Enclosure Dimensions

3.3 Wall or Pipe Mount

A PVC mounting bracket with attachment screws is supplied with each controller. The bracket is attached to the rear of the enclosure. The bracket provides for either wall or pipe mounting as shown in Figure X. Note that bracket slots are for u-bolts with 1/4-20 threads. The 1/2" pipe u-bolt (2" I.D. clearance) is available from ATI in type 304 stainless steel under part number 47-0005

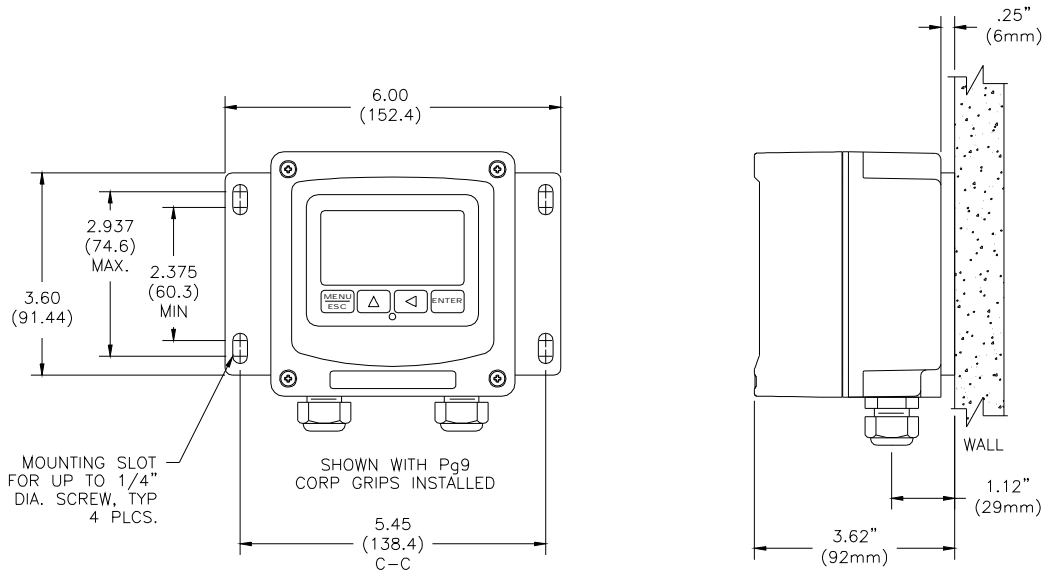

Figure 5 - Wall Mount

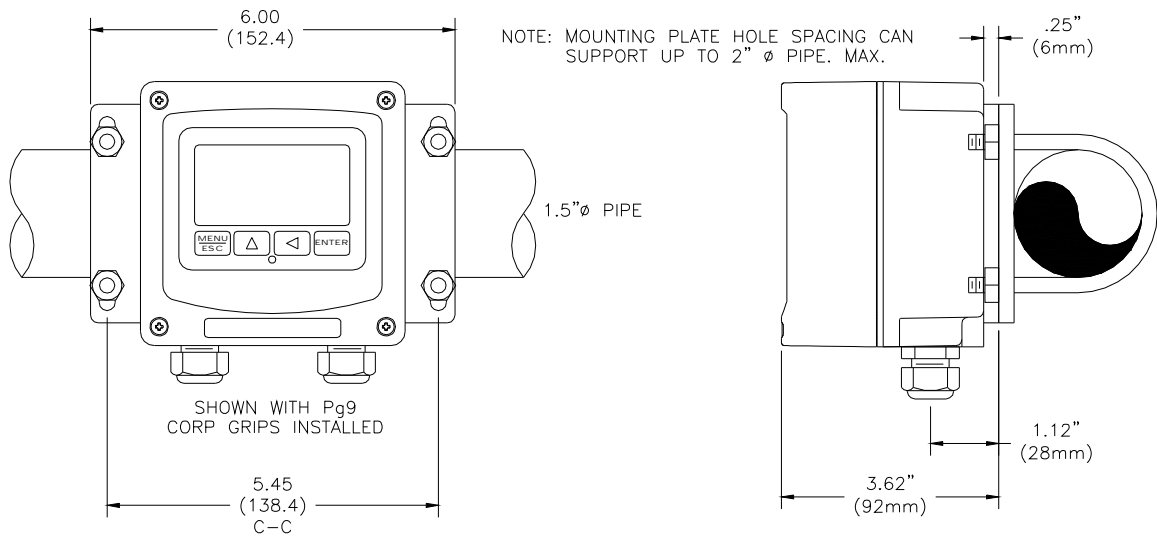

Figure 6 – Pipe Mount

3.4 Flow System Mounting

Flow chambers for MetriNet systems are modular so the size will vary depending on the number of M-Nodes to be used. Flow chambers should always be mounted vertically, with sample entering at the bottom and exiting at the top. This arrangement insures that air does not collect near a sensor and cause inaccurate readings. Conductivity and turbidity sensors can be extremely sensitive to trapped air.

Flow chambers are supplied with DIN rail adapters for 35x7.5 mm rail. The adapters are spring loaded to allow assembled flow chambers to snap onto the rail. All chambers should be clamped together prior to putting them on the rail. Chambers clamp together using clamping rings. The picture below shows two flow chambers disconnected. Although not shown, there is an o-ring in the inlet side of the flow chamber for sealing. When disconnecting, be sure the o-ring remains in place.

The lock rings between flow chambers and inlet/outlet fittings rotate downward by about 45 degrees to open and back up to close again. Opening and closing flow assemblies is not normally required except possibly for cleaning or inspection. It takes a bit of practice to reassemble these chambers.



Figure 7 – Disconnected Flow Chambers

The overall size of a flow assembly will depend on how many M-Nodes are to be used. Shown below are dimensions for height and width. The overall length will vary from about 6" (152 mm) for a single assembly to about 13" (330 mm) for a 4-chamber assembly. It is best to limit assemblies to no more than 5 M-Nodes, using a second assembly and interconnecting the two assemblies if larger systems are to be used. For example, a 6 Node system would be easier to handle with two 3-chamber flow assemblies connected by tubing. If two flow assemblies are used, run tubing from the outlet of the first back down to the bottom of the second so the flow is in the UP direction through both assemblies.

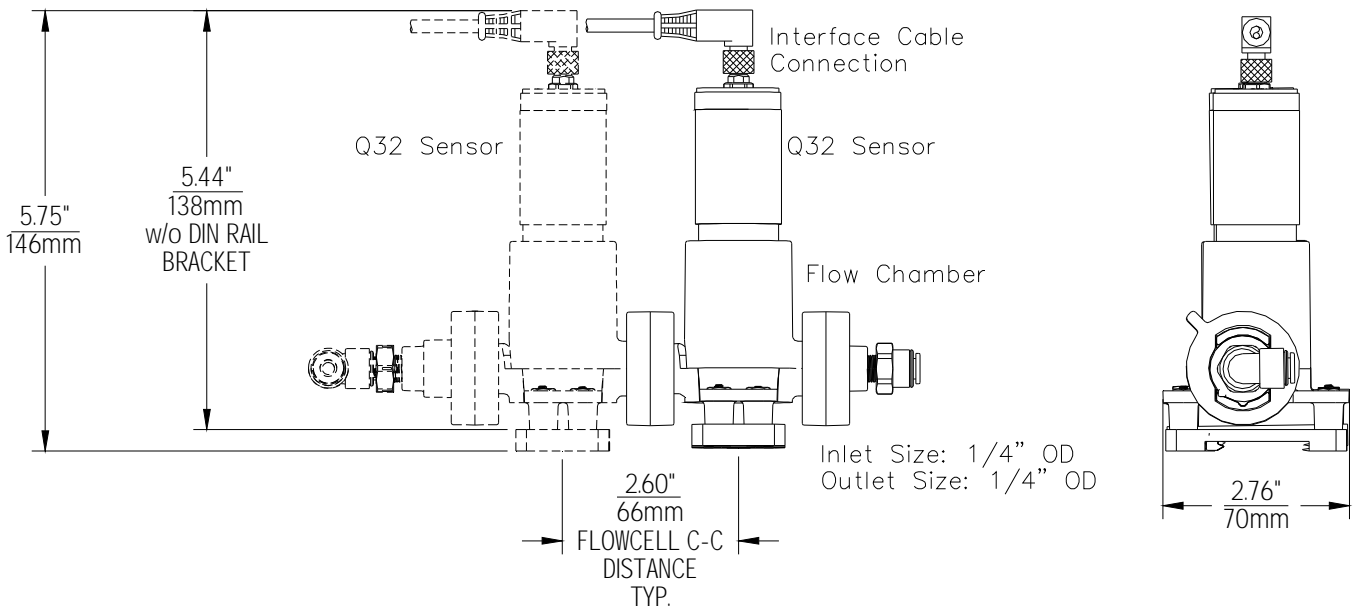

Figure 8 – Flow Chamber Dimensions

3.5 Bus Bar Mounting

MetriNet controllers connected to only one sensing node will not use a bus bar. All systems with more than one sensor will need at least one. The bus bar is an assembled communication network allowing the controller to speak to any node connected to the bus bar.

There are connectors for up to 5 nodes on each bar. If more than 5 nodes are to be used, 2 bars will be needed plus a jumper cable to connect the 2 bars together. The use of 2 bus bars allows a maximum of 8 nodes to be connected to a single controller. Bus bar dimensions are shown below. Bus bars should always be mounted close to and parallel to the flow assembly so that node cables can reach the connectors on the bus bar.

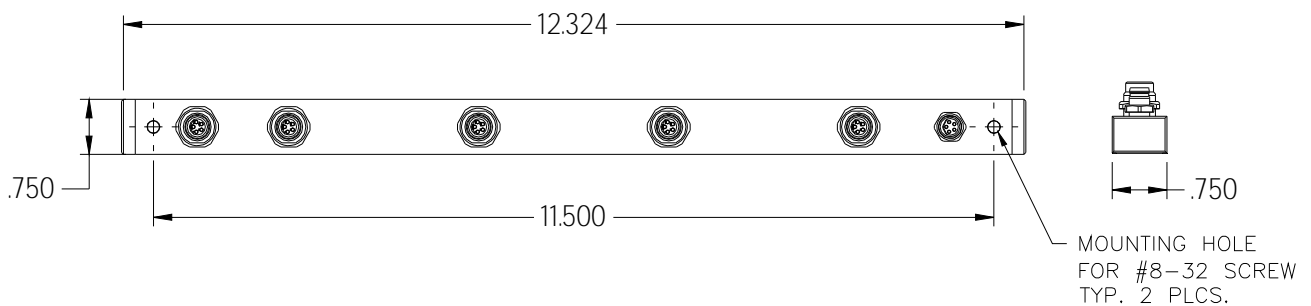

Figure 9 - Sensor Bus Bar Interface

3.6 Sample Connection

Flow systems are designed to use ¼” OD polyurethane or other semi-rigid tubing. Sample is normally coming from pressurized water pipe and flow systems can handle sample pressures as high as 100 PSIG. However, we recommend that inlet pressure be reduced to about 30 PSI if source water pressure is above 60 PSI. A typical sample arrangement is shown in Figure 5 below. It consists of a shutoff valve, an optional tee with Pressure Node, and pressure reducer. The optional flow control solenoid is also shown, followed by tubing connection to the flowcell. If a pressure sensor is to be used in the MetriNet system, it should be installed between the shutoff valve and the pressure regulator as shown in order to properly measure line pressure.

If pressure measurement is not needed and flow control is not used, your sampling system would only consist of an isolation valve and pressure regulator. Even the pressure regulator may not be required when monitoring lines that don’t exceed 60 PSI (4 bar).

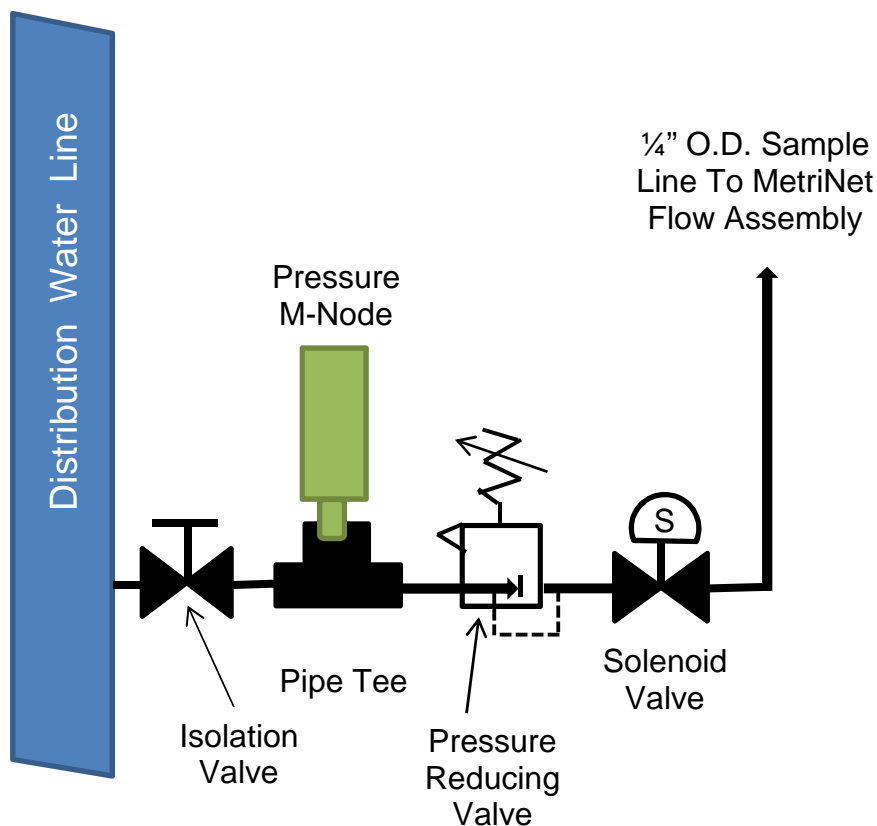

Figure 10 – Typical Installation Sample Connection

3.7 Intermittent Sampling

Water samples for MetriNet systems often run continuously, controlled at 200 ml/min. by a flow control device in the outlet assembly. However, the MetriNet controller can turn on flow intermittently to greatly reduce water consumption. An optional latching solenoid valve is available for this purpose. The solenoid valve is located after the pressure regulator as shown in Figure 8 and is wired to terminals inside the controller.

The intermittent sampling scheme is part of the controllers “Cycl” mode. When used, sample flows from the pipe for a short time prior to sensor measurements being recorded. The exact amount of time depends on sample line length but can reduce water consumption from 75 gallons per day down to 5 or 10% of that value depending on the frequency of measurement. Additional details can be found in Part 6 of this manual.

3.8 Electrical Connections

There are only a few connections required for installation of a MetriNet system. All connections are in the controller and the main communication cable connection is made at the factory during testing. Customer connections are DC power and the external solenoid valve, if that option is used.

MetriNet controllers are powered from either a local 12-24 VDC power supply or from a battery pack. Controllers designed for 12-24 VDC should be used on installations powered with either an external power supply or a battery system connected to a float charger. Battery powered controllers should only be connected to battery packs. These units are designed for minimum power consumption and some protective components have been removed.

Figure 9 below identifies DC connection terminals as well as terminals for the sensor bus and optional external solenoid. Note that controllers are supplied with only 2 cable glands installed. A third cable gland is supplied but not installed. The red plug on the bottom can be removed to install the additional gland. That gland will accommodate 2 cables, one for the solenoid wiring and a second for an external trigger. If only one hole is used, put a short piece of cable in the second hole to act as a seal.

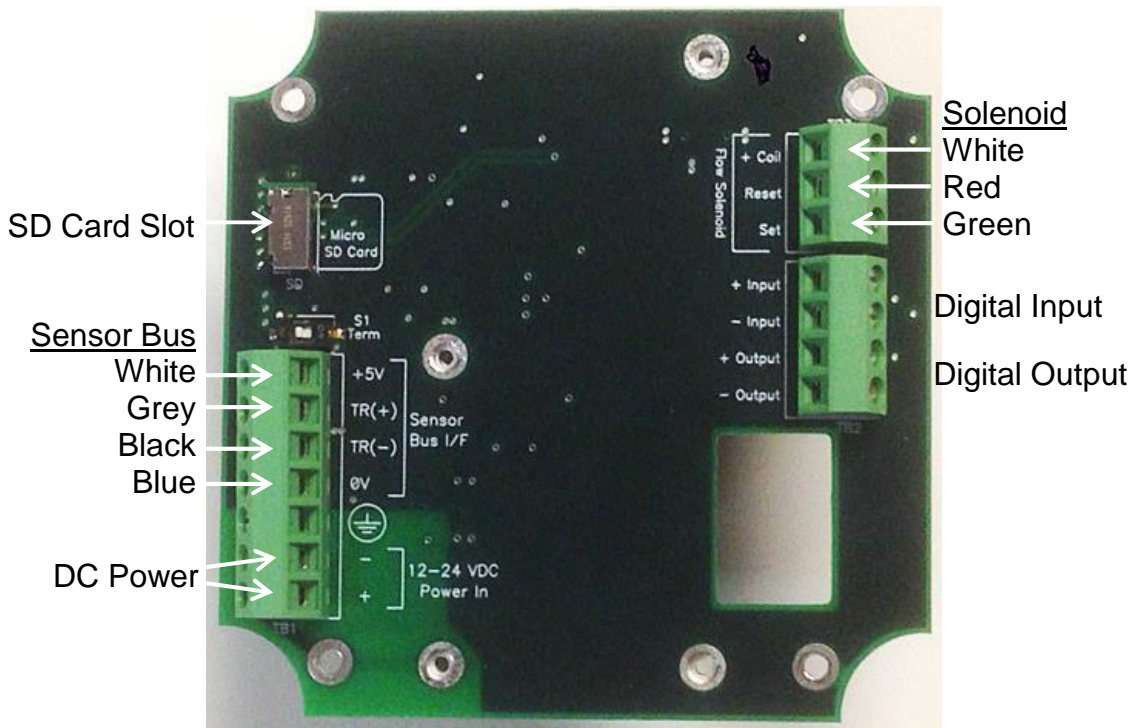

Figure 11 – External Connections

3.9 Power Consumption

MetriNet components are designed to minimize power usage. The total amount of power used depends on the number of M-Nodes used, whether operation is full-power or low-power, whether a cellular modem is used and the frequency of call out, and whether the controller is 12-24 VDC or battery only. For systems with a cell modem enabled, predicting the exact usage is not possible due to the wide variation in modem power usage.

The table below is intended to be a rough guide in determining the size of a power supply or battery pack required for a specific installation. Line powered DC power supplies should be large enough to deliver an instantaneous start-up current of 2 to 3 times the normal current. Battery supplies will normally handle very short duration start-up pulses. Estimating battery pack life and sizing solar power systems requires the use of information in this table.

<u>System Type</u>	<u>Full Power Mode (12V)</u>	<u>CYCL Mode (12V)</u>
12-24 VDC with modem	43 mA + 3 mA/node	15 mA + 3 mA/node
12-24 VDC without modem	30 mA + 3 mA/node	15 mA + 3 mA/node
12 V battery with modem	26 mA + 3 mA/node	4 mA + 3 mA/node
12 V battery without modem	12 mA + 3 mA/node	4 mA + 3 mA/node

Note: During modem operation, power draw can spike to about 150 mA for the duration of the data transfer. A typical daily data transfer takes about 3 minutes.

3.10 M-Node Preparation

Sensor nodes are packed individually and some require preparation prior to use. Some require removal of a wetting cap and some simply require installation into the flow chamber. The table below provides guidance. Instructions for preparing individual sensor nodes are provided separately, as are the calibration instructions for that node.

<u>Parameter</u>	<u>Preparation Required</u>	<u>Calibration</u>
Free Chlorine	Membrane & Electrolyte	After startup
Combined Chlorine	Membrane & Electrolyte	After startup
Turbidity	None	Before startup
pH	Remove wetting cap	Before startup
Conductivity	None	Before startup
ORP	Remove wetting cap	Before startup
Dissolved Oxygen	Membrane & Electrolyte	Before startup
Fluoride	Remove cap	Before startup
Dissolved Ozone	Membrane & Electrolyte	After startup
Chlorine Dioxide	Membrane & Electrolyte	After startup
Peracetic Acid	Membrane & Electrolyte	After startup
Hydrogen Peroxide	Membrane & Electrolyte	After startup
Pressure	None	Not Required

3.11 Node Installation

Do not install nodes until sample has been connected to the flow chamber assembly and you are ready to turn on the sample flow. When ready, install a node in each chamber, aligning the pins and pressing them into the chamber. Once inserted, turn about 90 degrees to lock in place.

For systems that include conductivity as part of a multi-node assembly, it is best to put the conductivity sensor in the first flow chamber. This insures that any small amounts of electrolyte leakage from other sensors do not affect the conductivity measurement.

Part 4 – Operation

4.1 General

Check to see that sample is running through the flow assembly. Sample flow is controlled at 200 ml./min. If the system was not purchased with the flow control element, adjust the flow through the system with a valve placed on the outlet side of the flow assembly. Recheck all wiring and verify that the power supply is in the range of 12-24 VDC. The controller does not contain a power switch. It will operate as soon as DC power is applied. Once power is applied, the system will go through an initialization routine and then will begin to operate.

4.2 Controller Interface

The user interface for the MetriNet controller consists of a custom display and a membrane keypad. All functions are accessed from this user interface.

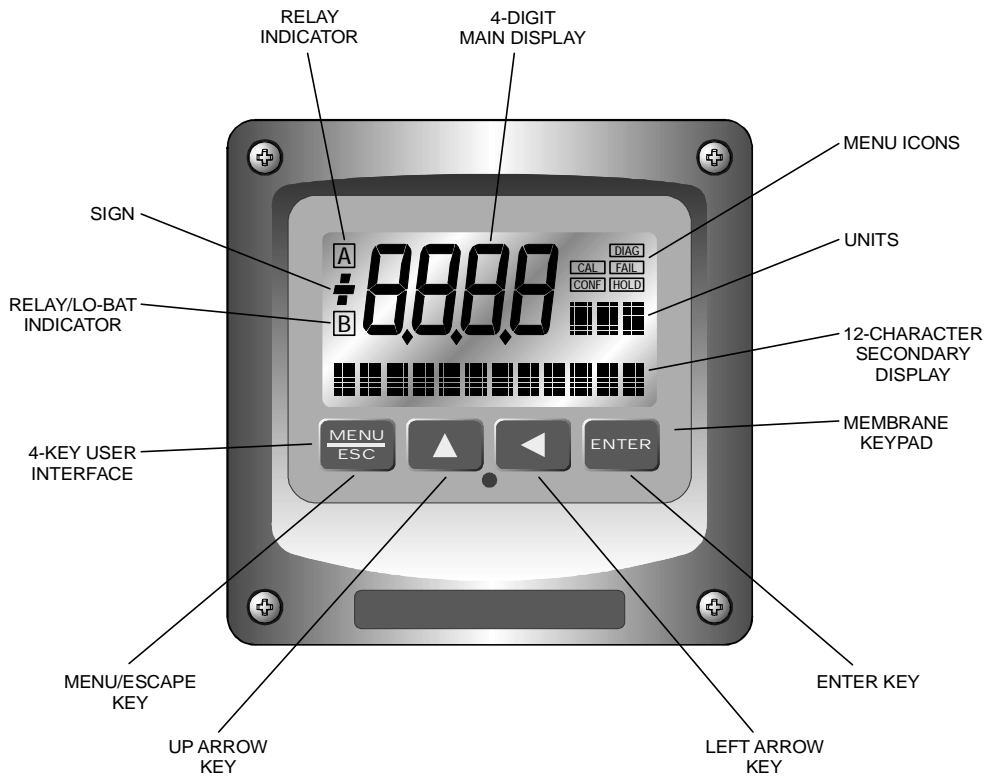

Figure 12 – MetriNet Controller Interface

4.3 M-Node Assignment

Each measurement node must have a unique sensor number. By default, all sensors are sensor #1. If there is more than one sensor in your system, a new sensor number must be assigned to each additional sensor. For fully assembled systems, sensor numbers are set at the factory. For other systems, use the following procedure.

NOTE: *Only 1 node may be connected to the controller during this procedure. Connect each node separately to assign a sensor number and then disconnect it prior to connecting another.*

1. Press Menu key to access CONFIG menu.
2. Press ▲ key until lower line display shows “Total Snr”.
3. Press Enter and the main number on the display will flash.
4. Use the ▲ key to adjust the flashing number to the total number of sensors in your system and then press Enter.
5. Press the ▲ key 3 times to access “Addr Snr” and then press Enter.
6. The display will flash “NO”. Press ▲ once for “YES” and press Enter.
7. The controller will show the current sensor number assigned to that node and it will be flashing. Use the ▲ key to set the required sensor number and press Enter.
8. Repeat steps 1-7 for each M-Node in the system until you have assigned a unique number to each one.

After each sensor has been assigned a unique number, connect all nodes to the bus bar. The controller will now be able to communicate with all nodes.

4.4 Controller Programming

The MetriNet controller is used to calibrate the measurement nodes, to store data supplied by the nodes, and to communicate the stored data to the outside world. The nodes are really independent analyzers, measuring a water quality parameter and feeding the data back to the controller. Data is stored in non-volatile flash memory and written to an SD card located in the controller. Data can also be transmitted by cellular modem to cloud storage sites, or communicate via Modbus-RTU, Modbus TCP or Ethernet IP with local PLCs or other devices.

The controller program is organized into MEASURE, INFO, SENSOR, CONFIG, and OPTIONS menus. The software map on the following page lists those menus and the sub-menus below each of them.

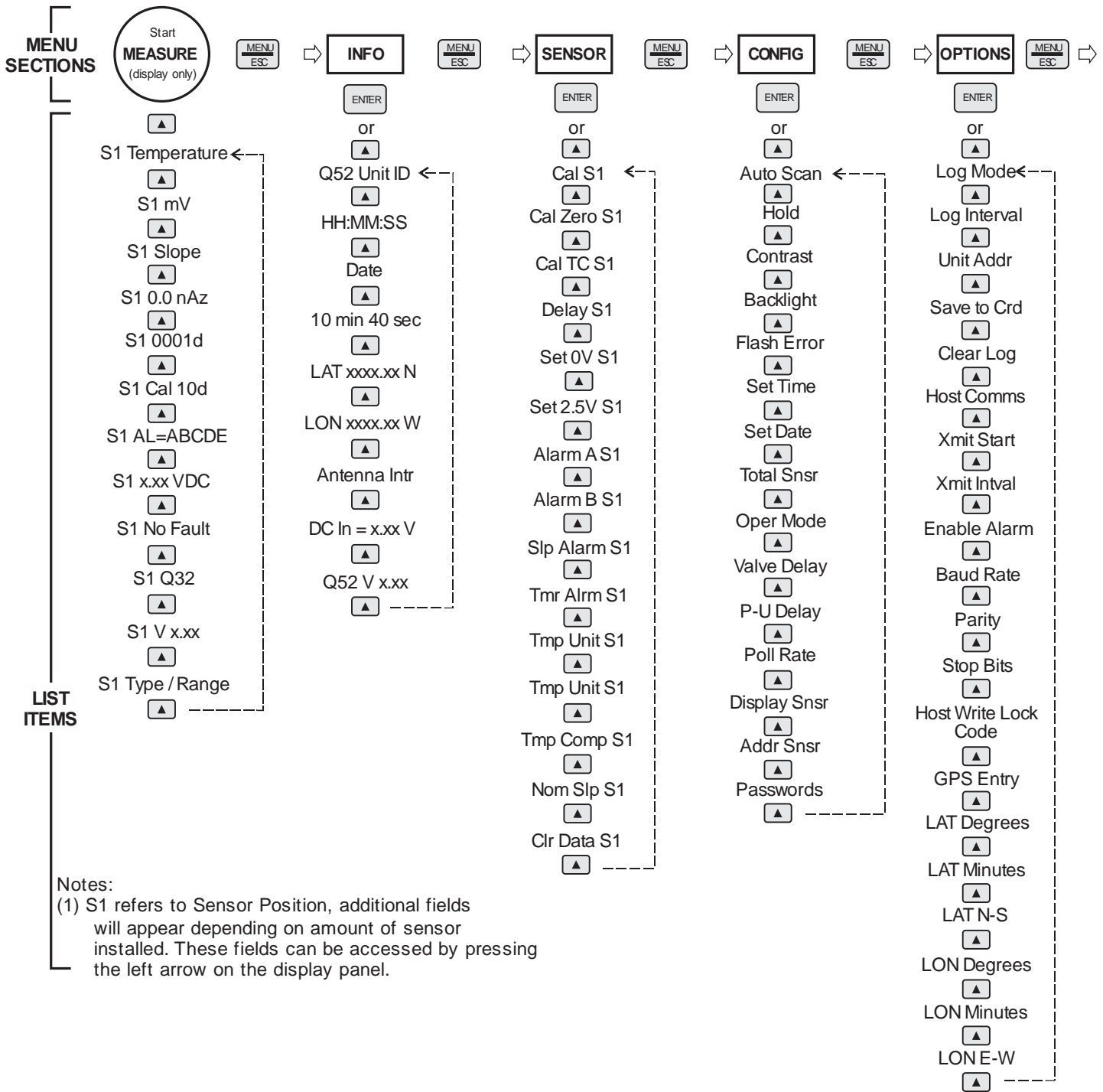

Figure 13 – Controller Software Map

4.41 MEASURE Menu

The default controller menu is MEASURE. This menu is display-only. When left alone, the unit will return to the MEASURE menu after 30 minutes. Note that the main display variable will scan through each node automatically. The lower line information applies to the node currently displayed. To stop the scan and look at information on an individual node, press the ◀ key. The scan will stop for 30 minutes but you can advance through each node using the ◀ key.

After selecting the node you wish to look at, use the ▲ key to scroll through variables on the lower display line. The information is not exactly the same for every node but includes the following.

NOTE: The S1 designation means sensor #1 and will change for each sensor.

S1 25.7°C	Temperature display. Can be displayed in °C or °F, depending on user selection.
S1 32.0 nA	Raw sensor data. Could be mA, mv., or other.
S1 100%	Sensor output response vs. ideal calibration. Also referred to as sensor “slope” and indicates sensor condition. Value updates after each calibration
S1 0.0 nAz	Sensor output current at a zero ppm input. Value updates after a zero-calibration.
S1 0001d	Sensor life run-time in days. Indicates how long the sensor has been in operation.
S1 Cal 10d	Calibration timer. Indicates number of days since last calibration.
S1 AL=ABCDE	Alarm indicator. Shows which alarms are active.
S1 2.50VDC	Sensor voltage output.
S1 No Fault	Sensor fail message to define detected fault condition.
S1 Q32H0	Sensor type code.
s1 VX.XX	Sensor firmware version
S1 Res Clr/0-4.00	Identifies type of measurement and overall range. Display alternates between measurement type and range.

4.42 INFO Menu

The INFO menu provides some basic information on the MetriNet controller, also called the Q52. These menu items are for reference only.

Q52 UNIT 10	Specific ID of this Q52. User set.
13:59:40	Hour/Minute/Sec time. 24 hour format.

- Dec 31, 2016** Current date
- 10min 40sec** Time until next data point is recorded. Useful if you wish to perform service before next logged data point.
- LAT 1234.56N** GPS captured latitude position
- LON 1234.56W** GPS captured longitude position
- Antenna Intr** GPS using internal antenna
- DC In = 12.1** Measured DC input voltage (from battery or power supply)
- 192.168.000.020** Ethernet IP Address (Decimal Points implied)
- Q52 Ver X.XX** Q52 software version number

4.43 SENSOR Menu

The SENSOR menu provides all M-Node information and calibration controls. This menu information largely originates from sensor memory and there is some variation from sensor type to sensor type. The information on typical displays use a free chlorine sensor as an example.

The routines outlined below allow users to adjust various parameters and calibrate sensors. When making adjustments, pressing Enter will normally start the process. Values may be adjusted using the ▲ and ◀ keys. Pressing Enter again will accept the changes. Pressing Menu/Esc during a routine will cancel the adjustment and go back to the starting screen.

- Cal Chlr S1** Calibration routine for sensor span adjustment
- Cal Zero S1** Calibration routine for sensor zero adjustment
- Cal TC S1** Temperature calibration routine
- Delay S1** Routine for adjustment of sensor “damping” or response time
- Set 0V S1** Routine to adjust zero value for 0-2.5 V output. No adjustment necessary for sensors used with MetriNet systems. Used to set up sensors for other applications.
- Set 2.5V S1** Routine to adjust full scale value for 0-2.5 V output. No adjustment necessary for sensors used with MetriNet systems. Used to set up sensors for other applications.
- Alarm A S1** Setpoint for Alarm A. User may define an alarm limit above which the A alarm will be shown in the MEASURE menu.
- Alarm B S1** Setpoint for Alarm B. User may define a second alarm limit above which the B alarm will be shown in the MEASURE menu.
- Slp Alarm S1** User may define a “slope” alarm limit. If the sensor slope falls below that limit after a calibration, Alarm C is shown in the MEASURE menu.

Tmr Alarm S1	User may define an alarm limit for the time between calibrations. If a calibration is not done within the defined time period, Alarm D is shown in the MEASURE menu.
Tmp Unit S1	Allows temperature reading in degrees C or degrees F.
Tmp Comp S1	Allows modification of sensor temperature compensation.
Nom Slp S1	Normalizes slope to 100%. May be done after a sensor has been serviced and calibrated for the first time.
Clr Data S1	Resets all sensor stored data to factory default values.

4.44 CONFIG Menu

The CONFIG menu provides access to Q52 controller configuration settings. Routines defined here are not sensor specific. They define the overall function of the controller.

Auto Scan	Turns sensor scanning on and off. When ON, each sensor value is displayed for 4 seconds.
Hold	Freezes data being written to the data logger. Useful when sensor calibration or service is needed.
Contrast	Used to adjust LCD contrast. Default is 7. Range is 1-8.
Backlight	Turns LCD backlight on and off. Turn off when operating from battery power.
Flash Error	Programs LCD backlight to flash if an error is detected. Select "All" to flash on any sensor error. Select Sn9I (single) to flash display only when the sensor causing the error is displayed.
Set Time	Used to program current time. After pressing Enter, use a combination of the ▲ and Enter keys to adjust hours, minutes, and AM/PM.
Set Date	Used to program current date. After pressing Enter, use a combination of the ▲ and Enter keys to adjust year, month, and day.
Total Snsr	Defines how many sensor nodes are connected to the controller.
Power Mode	Defines whether the controller runs continuously (Cont) or only intermittently (CYCL). When operating from battery power, cyclic operation greatly reduces power consumption. In addition, an external solenoid may be controlled in Cycle mode in order to conserve water.
Valve Delay	If the optional solenoid is used to turn flow on and off, the valve delay value defines the delay time, starting from when the solenoid is opened, before sensor nodes are powered up to make measurements. Delay time depends on length of sample lines. Delay may be set from 1-99 seconds.

P-U Delay	When in CYCL mode, P-U delay defines the time period after the nodes are energized until the controller polls the nodes for data. Range is 1-99 seconds.
Poll Rate	When in CYCL mode, this defines the rate at which data will be recorded. In other words, this is the cycle rate. Range is 1-99 minutes.
Display Snsr	Tests communication to each sensor. Press Enter and status of comms for each sensor is tested. Sensor found indicate “Yes” while sensors not found indicate “No”. Press Enter again to exit.
Addr Snsr	Routine used to add sensors to a controller network. Use of this routine is describe in section 4.3 (Node Assignment).
Passwords	Sets a user specified Supervisor password. The default is 0000, which means the password is disabled. Once a supervisor password is set, only those with that code may change the overall system configuration items and option items. After 5 unsuccessful attempts, the unit will lock for 30 minutes. An additional 5 “User” passwords may be assigned by the supervisor. Those assigned a user password may make adjustments to items in the SENSOR menu, such as sensor calibrations. Detailed instructions on setting passwords are found in section 4.5.

4.45 OPTIONS Menu

The OPTIONS menu contains settings related to the data logging function and the internal cell modem, Modbus option or Ethernet module option if installed.

Log Mode	Turns the data logger on or off and defines whether logging is continuous or stops when memory is full. If the data logger is shut off, the modem is disabled.
Log Interval	Sets the data storage interval. Range is 0.1 to 99.9 minutes.
Unit Addr	Defines the Q52 Modbus address. If you have multiple MetriNet systems operating, it is best to have a unique address for each. This number is part of the data log and is used to identify the controller that supplied the data. It is also used as the Modbus address if the unit is connected to an external Modbus network. Range is 1-247.
Save to Crd	This routine allows data stored in flash memory to be written to an SD memory card. The SD card is removable for data transfer to a laptop or PC.
Clear Log	This routine clears all data stored in flash memory. Once cleared, it cannot be recovered. Verify that all data has been saved (or is not needed) prior to clearing the log.
Host Comms	Enables internal modem or communications interface if installed.
Xmit Start	Defines when the first data transmission by modem will occur. Range is 00-23, 00=midnight, 23=11 PM.

Xmit Intval	Sets the interval between modem data transmission.
Enable Alarm	Enables sending the Alarm Record when the Cell Modem option is installed.
Host Baud Rate	Sets the Baud Rate for the Modbus Interface. 9600 or 19.2K Baud.
Host Parity	Sets parity for Modbus interface. None, Even or Odd.
Host Stop Bits	Sets number of stop bits for Modbus interface. 1 or 2
Host Write Lock Code	Range is 0 – 9999. Host must write unlock code when calibrating or changing any settings via Modbus interface.
GPS Entry	Allows auto Capture or Manual entry of GPS Latitude and Longitude Data.
Lat Degrees	Range is 0 – 90. Enter the first two digits (DD) of the Latitude. Format for Latitude is DDMM.MM N/S.
Lat Minutes	Range is 00.00 – 99.00. Enter the next four digits (MM.MM) of the Latitude.
Lat N-S	Enter N for North, enter S for South.
Lon Degrees	Range is 0 – 90. Enter the first three digits (DD) of the Longitude. Format for Longitude is DDDMM.MM E/W
Lon Minutes	Range is 00.00 – 99.00. Enter the next four digits (MM.MM) of the Longitude.
Lon E-W	Enter E for East, enter U for West.

4.5 Set Passwords

MetriNet systems are designed with 2 levels of password protection to prevent unauthorized adjustments. There is one Administrator password and up to 5 separate User passwords. All passwords are numerical, consisting of 4 digit numbers.

As shipped, controllers are not password protected. All passwords are disabled and the user must decide whether to use password protection or not. Some of the events recorded in the Event Log are tied to the password entered in order to perform the recorded function.

The Administrator sets the administrator password and programs all user passwords. The following steps are needed to set passwords.

1. Go to OPTIONS Menu and press ▲ repeatedly until bottom line indicates Passwords.
2. Press Enter. Display will show 0000 with right digit flashing. Using the ▲ and ◀ keys, enter a 4-digit supervisor password.
3. Press Enter and that number will be recorded.

4.6 Sensor Display

Controller units can display measurements from up to 8 M-Nodes. The display operates either in Auto-Scan or Manual modes. The first routine in the CONFIG menu turns the Auto-Scan function on or off. The default mode is ON. With Auto-Scan on, the display will show the measured value of each node for 4 seconds and then switch to the next one. All measurements may be observed by simply watching the display.

To manually sequence through the nodes, press the ◀ key. The first time the key is pressed, the scanning mode will stop. By pressing the ◀ key repeatedly, you can cycle through all measurements. If no key is activated for 30 minutes, the display will revert to scan mode.

Interrupting the scan mode allows you to look at specific sensor data and do calibrations or other adjustments. When you select a specific sensor using the ◀ key, you can then sequence through the information screens on the bottom line using the ▲ key. The contents of each information screen are summarized in section 4.41.

Once you have selected a specific node, you can go to the SENSOR menu for that node by pressing Menu twice. From the SENSOR menu, you can adjust sensor zero and sensor span, calibrate temperature, set alarms, and adjust other settings as outlined in section 4.43.

NOTE: If passwords are enabled, you must enter your password in order to make sensor adjustments.

Part 5 – Data, Alarm & Event Log

5.1 General

The primary purpose of a MetriNet system is to monitor water quality parameters and log the data. The data may then be either transmitted to a remote data storage cloud site by modem or collected manually by writing data to the SD RAM card located in the controller. The amount of data depends on the number of sensors used and the logging frequency.

5.2 Data File Format

Data stored and transmitted is in a standard .CSV format. Data can be easily displayed and analyzed using Excel or other spreadsheet programs. Shown below is part of a typical data file that has been sent by modem to a storage site. When copied to the SD Card, the file name is Q52DLnnn where nnn is the unit address number.

Data Record										
Date	HH:MM:SS	Temp	Sensor 1	Sensor 2	Sensor 3	Sensor 4	Sensor 5	Sensor 6	Sensor 7	Sensor 8
12/8/2016	13:01:47	13760	467800	1726	1684	7150	0	0	0	0
12/8/2016	13:06:47	13760	467800	1727	1679	7150	0	0	0	0
12/8/2016	13:11:47	13760	467400	1729	1694	7150	0	0	0	0
12/8/2016	13:16:47	13760	467800	1726	1679	7150	0	0	0	0
12/8/2016	13:21:47	13760	467800	1726	1702	7150	0	0	0	0
12/8/2016	13:26:47	13750	468000	1728	1696	7150	0	0	0	0
12/8/2016	13:31:47	13750	467600	1729	1664	7150	0	0	0	0
12/8/2016	13:36:47	13750	467600	1725	1676	7150	0	0	0	0
12/8/2016	13:41:47	13750	467600	1727	1672	7150	0	0	0	0
12/8/2016	13:46:47	13750	468000	1723	1690	7150	0	0	0	0
12/8/2016	13:51:47	13750	468000	1730	1677	7150	0	0	0	0
12/8/2016	13:56:47	13740	468100	1722	1661	7150	0	0	0	0
12/8/2016	14:01:47	13740	468100	1725	1694	7150	0	0	0	0
12/8/2016	14:06:47	13730	467800	1725	1694	7150	0	0	0	0
12/8/2016	14:11:47	13740	467700	1722	1659	7150	0	0	0	0
12/8/2016	14:16:47	13730	467800	1725	1694	7150	0	0	0	0
12/8/2016	14:21:47	13740	467700	1722	1664	7150	0	0	0	0
12/8/2016	14:26:47	13730	468200	1725	1691	7150	0	0	0	0
12/8/2016	14:31:47	13730	468200	1720	1672	7150	0	0	0	0
12/8/2016	14:36:47	13720	468300	1722	1679	7150	0	0	0	0
12/8/2016	14:41:47	13720	467900	1720	1672	7150	0	0	0	0
12/8/2016	14:46:47	13720	467900	1718	1665	7150	0	0	0	0

Figure 14 – Raw Data Format

All data is stored as 16-bit data with 4 decimal resolution. In order to convert raw data to actual engineering units, simply divide each value by 1000. Since each controller can accommodate up to 8 nodes, zero values are stored for each unused sensor input. Data manipulation such as appending files and generating graphical reports is left to the user.

5.3 Alarm File Format

In addition to the data log file, the controller also generates an alarm log file. The alarm file format is similar to the data file format. When copied to the SD Card, the file name is Q52ALnnn where nnn is the unit address number. The alarm file logs an alarm event any time one of the sensor setpoints A or B changes state. If communications is lost to a sensor, Error is shown. The time stamp shows when the alarm occurred. Up to 200 alarm events may be stored.

Q52 Alarm Record									
Date	HH:MM:SS	Sensor 1	Sensor 2	Sensor 3	Sensor 4	Sensor 5	Sensor 6	Sensor 7	Sensor 8
8/22/2018	1:28:43	OK	OK	OK	OK	0	0	0	0
8/22/2018	21:18:36	A	OK	OK	OK	0	0	0	0
8/22/2018	21:20:58	OK	B	OK	OK	0	0	0	0
8/22/2018	23:09:22	OK	OK	A B	OK	0	0	0	0
8/22/2018	23:23:10	OK	B	A B	OK	0	0	0	0
8/22/2018	23:26:20	OK	OK	AB	OK	0	0	0	0
8/25/2018	20:26:48	OK	OK	OK	OK	0	0	0	0
8/25/2018	20:28:24	OK	OK	OK	Error	0	0	0	0
8/25/2018	21:02:06	OK	OK	OK	OK	0	0	0	0

5.4 Event File Format

In addition to the data log file, the controller also generates an event log file. The event file format is similar to the data file format. When copied to the SD Card, the file name is Q52ELnnn where nnn is the unit address number. The event file does not contain a lot of information and many times has nothing at all. However, it is intended to record certain changes as they occur. The following are the events currently stored. Up to 100 events may be stored.

Q52 Event Record				
Supply Voltage	12.1			
Latitude	GPS Off			
Longitude	GPS Off			
Date	HH:MM:SS	Sensor	Event	
9/10/2018	10:57:45	0	EventLog Cleared	
9/10/2018	14:33:43	0	Sup Passwd Entry	
9/10/2018	14:40:25	0	User1 Passwd Entry	

5.5 SD RAM Card

MetriNet controllers contain a micro-SD card slot on the terminal block circuit board just above the bus connections (see photo in section 2.7). As previously mentioned, data is stored in flash memory in the controller. Data can be manually removed by writing the data to a micro-SD card and then removing the card from the controller.

Controllers are supplied with 2 GB SD cards. To retrieve data manually, simply write stored data to the SD card using the “Save to Crd” routine in the OPTIONS menu. Many new computers have micro-SD slots while others will only accept the larger format SD card. An adapter is supplied so that micro-SD cards can be inserted into standard SD card slots.

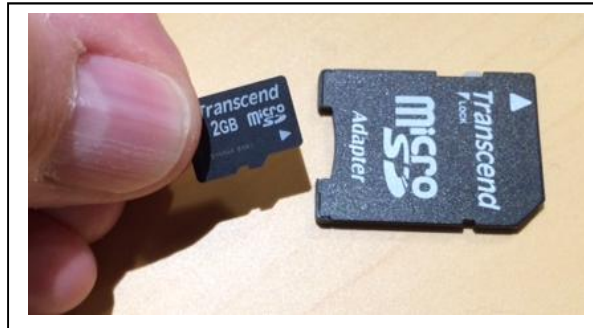

Figure 15 – Micro-SD Card With Adapter

5.6 Data Storage Capacity

MetriNet controllers can store large amounts of data. The time period required to fill the memory depends on how many nodes are connected and how often data is stored. A controller with a maximum of 8 nodes logging data every 6 seconds can store 48 hours of data. That’s about 230,000 data points. A more typical application with 4 M-Nodes taking data once every 10 minutes will hold about 239 days of data.

Data held in flash memory may be recorded until the memory is full or it may be stored in a circular file, with the oldest data overwritten by the newest data once the memory is full. The selection is made in the “Log Mode” routine of the OPTIONS menu. Choosing “Cont” selects a circular file mode of operation. Selecting “Full” stops the data logging when the memory is full.

5.7 GPS Function

MetriNet controllers contain a GPS chip that allows the controller to transmit its position to the data site. This function is mainly useful if you plan to move the system around to different locations. However, it can also be useful if the location of the installation is to be displayed on a mapping program.

The GPS function is accessed using the “GPS Entry” routine in the OPTIONS menu. The GPS data is only acquired when “Search? YES is selected. The GPS Status will be displayed on the lower line of the display. It can take up to 5 minutes to acquire GPS location data.

If a location is found, the lower display will show the Latitude for a few seconds, then display the Longitude for a few seconds, then exit the function. Once the position is acquired, the data will be stored in Flash Memory and need not be updated unless the system is moved to another location.

If a location is not found, current Latitude and Longitude data is preserved, and the display will advance to the “Manual Entry?” Prompt. If YES is selected, the unit will advance to manual entry of Latitude and Longitude data.

The antenna for the GPS chip is internal to the controller and is not a strong receiver. It may be necessary to temporarily activate the controller outdoors at the installation site to get valid data.

Part 6 – Cycle Mode

6.1 General

As mentioned earlier in the manual, MetriNet controllers can be operated in either “Full” or “Cycl” power modes. The Cycl mode is used to either extend battery life, reduce sample water consumption, or both. Reduction in sample water consumption requires the use of an external latching solenoid valve available from ATI under part number 36-0067.

6.2 Power Sequence

When a MetriNet controller is programmed for Cycl mode, operation of the measuring system is intermittent. During part of the cycle, all sensors are powered down and the controller is in “sleep mode”. The overall cycle period is defined in the “Poll Rate” setting of the CONFIG Menu.

During a cycle, the controller remains in sleep mode until a measurement is required. At that time, the “Valve Delay” interval will begin. If a solenoid is in the system, the solenoid opens to allow sample to flow. After that period, the P-U Delay period begins. P-U Delay is the power-up delay. This is the time during which measurement nodes are energized so that a measurement may be made on the flowing sample. At the end of that period, a data point is stored, nodes are again powered down, and the solenoid valve is closed (if used). The line diagram below shows a typical sequence schematically.

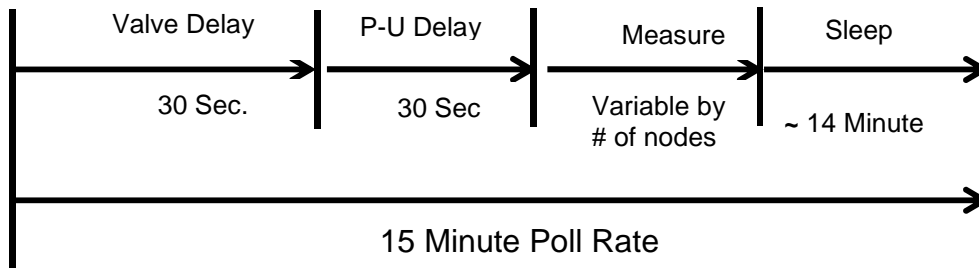

Figure 16 – Cycle Mode Schematic

6.3 Valve Delay

The purpose of the valve delay is to ensure that sensing nodes are exposed to fresh sample for a long enough period of time to get good measurements. For systems where flow is continuous, the valve delay setting should simply be left at the lowest value.

If a system is using solenoid flow control, be sure that the valve delay is long enough so that fresh sample reaches sensors for at least 30 seconds. For estimating the required time, you need to take into account the length of your sample line. Using standard ¼” O.D. polyurethane tubing, you will need approximately 1 second for every 1 foot (3 seconds per meter) of sample tubing from the source pipe to the flow assembly. Assuming you have a 20 ft. sample line, you will need a valve delay of 20 + 30 or a total of 50 seconds in order to ensure that sensors have seen fresh sample for at least 30 seconds prior to measurement.

6.4 Digital Input

Under some conditions, a user may wish to initiate a measurement cycle using an externally generated contact closure. As an example, an alarm from another device might be used to tell the MetriNet controller to take a reading. Digital input terminals are provided for that purpose.

6.5 Digital Output

A digital output is available to provide an external indication of an alarm condition. The output toggles on and off in parallel with the backlight flash function. This output will toggle even if the backlight is programmed to OFF.

Part 7 – M-Nodes

7.1 General

M-Nodes are integrated sensor and electronics assemblies that measure a particular water quality parameter. Sensing elements are connected to internal amplifiers that provide data to a micro-computer and the data is then sent to the outside world using Modbus communication. All measurement and communication functions are embedded in the node and the entire assembly is potted for physical protection. An IP-67 connector on the back is used to wire the node to MetriNet bus bars or controllers.

As noted earlier in this manual, there are a number of different measurement nodes available. While installation of each node is the same, some require specific steps to prepare the sensor for use.

7.2 Free Chlorine M-Node

Free chlorine nodes employ a membrane covered amperometric sensor that generates a small current proportional to the free chlorine concentration in the sample. FCI_2 nodes require installation of a membrane and electrolyte prior to use. A package of membranes and a bottle of electrolyte are supplied with the node. Figure 15 shows an exploded view of that sensor.

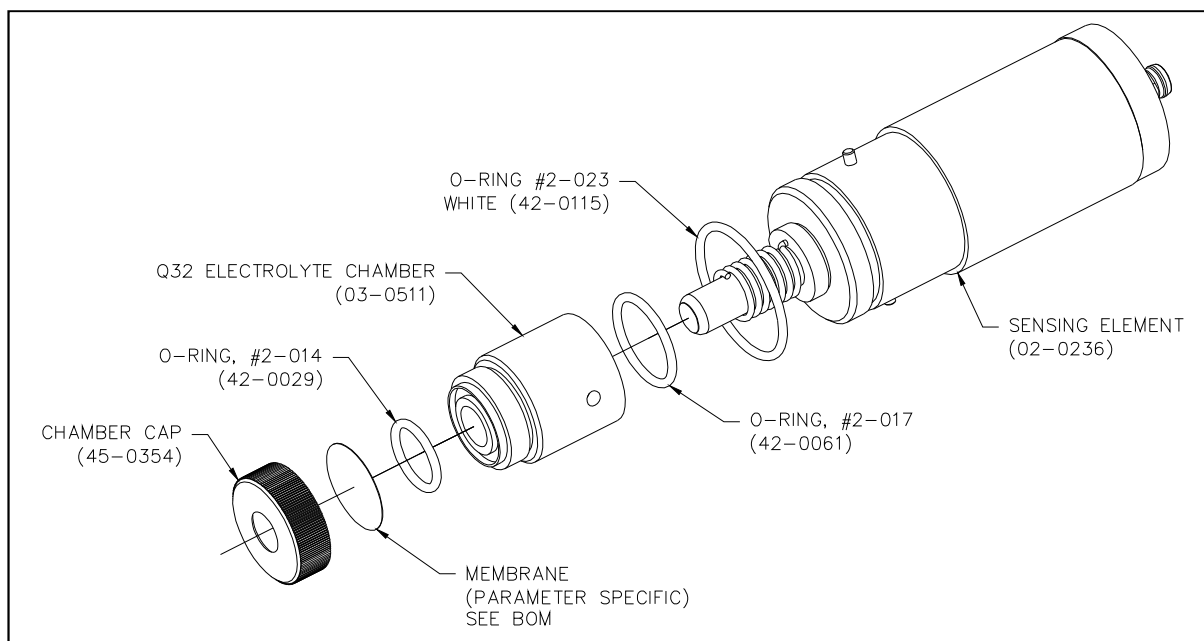

Figure 18 – Chlorine Sensor Exploded View

To prepare the sensor for operation, follow these steps.

1. Unscrew the electrolyte chamber from the node body. If it is filled with electrolyte, discard and rinse with distilled water.
2. Remove the membrane cap and discard the membrane.

3. Remove a new membrane from the membrane container and carefully place it in the bottom of the membrane cap. Be sure your hands are clean before handling membranes. Grease and oil on a membrane will cause measurement failure.
4. Screw membrane cap onto electrolyte chamber. Tighten securely and then fill chamber to the middle of the internal threads with electrolyte.
5. Screw the electrolyte chamber onto the node body and tighten firmly. A small amount of electrolyte may come out of the white vent on the side of the chamber. This is normal.

CAUTION: The electrolyte solution is a harmless salt solution. However, those with particularly sensitive skin may wish to wear latex gloves when completing the above procedure. Avoid eye contact with electrolyte. Should eye contact occur, flush for 5 minutes with clean water. Consult a doctor if eye irritation persists.

7.21 Free Chlorine Span Calibration

Free chlorine sensing nodes require stabilization time. Prior to calibration, install the node in its flow chamber and turn on the sample flow. Connect the sensor to the MetriNet controller and turn on the power. New sensors should be allowed to run for 8 hours prior to calibration. Sensors that have been used for weeks or months will stabilize within 2-4 hours after membrane and electrolyte changes.

NOTE: Chlorine sensors will stabilize without continuous flow of sample. It is enough to fill the flow chamber with water and then shut off flow if desired. The sensor must be connected to a controller with power on for stabilization.

Once the sensor is stable, make sure that sample is flowing for at least 10 minutes prior to calibration. Then follow these steps.

1. Press controller Menu key twice to get to SENSOR on the lower line. After a few seconds, it will change to Cal Chlr Sx (x is sensor #). The numerical display will show the current free chlorine measurement.
2. Observe the display to be sure the chlorine value is not steadily increasing or decreasing. You cannot calibrate on a sample that is constantly changing. The display value should be stable within about 0.2 ppm.
3. Collect a sample of the water coming from the outlet of the flow assembly and use a portable test kit to measure the free chlorine value.
4. Press Enter and the first digit will flash. Use the ▲ key to adjust that digit and then the ◀ key to move to the next digit.
5. Once your display value matches the result of your test kit, press Enter and the sensor will be calibrated and a new "Slope" value calculated.

NOTE: The slope value is meant to be an indicator of sensor condition. The absolute value is not particularly critical. The best use of this number is to see how the calibration has changed since the last calibration. Prior to calibration, go to the MEASURE Menu and check the current slope value. Compare that value to the new value calculated after a calibration. As an example, your system has a slope of 125% prior to calibration. After calibration, the new slope is 113%. During the interval between the first and second calibrations, the sensitivity has changed by 12/125 or about 10%. This information can help in determining the frequency of calibration required for a given site.

7.22 Free Chlorine Zero Calibration

Free chlorine sensors have very low offsets and very good zero stability. Zero adjustment is normally not required. It is possible to check and adjust the zero if you wish. Follow these steps.

1. With the sensor connected to the controller and the controller powered up, remove the sensor from the flowcell and rinse with distilled water.
2. Place the sensor in a small container of distilled water so that the bottom half of the sensor is covered.
3. Allow the sensor to sit undisturbed for 15 minutes. In almost all cases, the display will be reading 0.01 or less.
4. To adjust zero, go to “Sensor” and then press ▲ until the lower line reads “Cal Zero Sx”.
5. Press Enter and wait for a few seconds. Then press Enter again and the zero will be updated.

7.23 Free Chlorine Maintenance

Free chlorine sensors use a microporous membrane that can accumulate coatings from iron, manganese, and other particulates in the water. The rate at which this occurs is highly variable. Some applications have run for 1 year without a membrane change while other struggle to get to 1 month on a membrane. There is no way to predict this and only experience at each location will answer the question of how often membranes should be changed. In the previous section, there is a note on “Slope”. The rate of change of the slope value observed after each calibration can give you an idea as to how long a membrane will last.

That slope value change will also give you an indication as to how often calibration is even necessary. For example, you install a chlorine node at a site and do an initial calibration. The slope is 110%. You come back to recalibrate 2 weeks later and the slope is 108%. This 2% change is probably within the error of your test kit. In essence, the sensitivity of your sensor did not change in 2 weeks. Clearly, a calibration every 2 weeks is not needed. Extend the interval to 1 month and repeat the test. From experience, many installations require calibration no more than every 2-3 months and some are much longer.

When maintenance is required, which is indicated by a slope value dropping to less than 50% of its value after the first calibration, the membrane and electrolyte should be changed. Repeat the procedure outlined in section 7.2.

7.3 Conductivity M-Node

The Conductivity M-Node is a 2-Electrode conductivity sensor with integral Pt1000 RTD temperature element. It has an operating range of 0-2000 uS and is designed for clean water application. There are no accessories supplied with this node. It is factory calibrated, but can be adjusted in the field if desired. Conductivity M-Nodes should last at least 5-10 years in normal service.

7.31 Zero Adjustment

It is normally not necessary to make any zero adjustments to a conductivity sensor. If you wish to verify zero, simply remove the sensor from the flowcell and dry the titanium electrodes on the end of the sensor. The MetriNet display will read 0 uS on the conductivity node display. If the display does not read zero under these conditions, the zero may have been inadvertently adjusted when in solution. The zero can be reset simply using the following steps.

1. On the MetriNet display, go to the SENSOR Menu and use the ▲ key to select “Cal Zero Sx”. The x designates the conductivity sensor number.
2. Press Enter and the display value will flash. Press Enter a second time and the display will be set to 0 uS.

7.32 Conductivity Calibration

Conductivity nodes are calibrated at the factory and adjustment at startup is normally not required. Calibration can be done easily if desired by either dipping the sensor into a known calibration standard or by adjusting the display to a sample value determined by measuring sample from the inlet line using a portable conductivity analyzer. Conductivity standards of 447 uS (part #09-0047) or 1500 uS (part #09-0048) are available from ATI.

To calibrate a conductivity M-Node, follow the steps below:

Remove the conductivity node from the flowcell and rinse with clean water. If necessary, wipe electrode surfaces with a soft cloth.

Pour conductivity standard into a small container. The level in the container must be a few inches above the titanium electrodes.

On the MetriNet display, go to the SENSOR menu. Be sure to select the conductivity sensor number using the ◀ key.

1. The first display will be “Cal Sx”. Press Enter and the display will indicate the conductivity value of the standard solution. If no adjustment is needed, press the Menu key to exit the routine.
2. If the value requires adjustment, press Enter and the first digit will flash. Use the ▲ key to adjust the digit and the ◀ key to move to the next digit. When the display shows the standard value, Press Enter. You will see the “accepted” message briefly, followed by the calculated slope value.
3. Remove the sensor from the standard, rinse, and reinstall in the flowcell.

7.33 Conductivity Maintenance

The only maintenance required on this type of sensor is cleaning. Use soapy water with a Q-tip or small brush to clean the inner electrode and the inner surfaces of the outer electrode. Spraying the electrodes with a commercial degreaser of the type used to clean kitchen appliances is often effective in cleaning the titanium surfaces.

7.4 pH M-Node

The pH Node is an assembly that uses a rebuildable combination pH electrode with a Pt1000 temperature element. The Modbus electronic interface is potted into the back of the assembly. The overall measuring range of this device is 0-14 pH but the practical range is 0-12 pH as the glass element becomes non-linear above a pH of 12. These pH measurement nodes are expected to have a 2-5 year life in normal service.

7.41 pH Calibration

Calibration of pH M-Nodes requires a 2point calibration, which establishes the “zero offset” and “slope” for the sensor. An initial calibration of each sensor is done at the factory using pH 4 and pH 7 buffers. Depending on the time period between when a sensor was shipped and when it is put into service, the zero offset of the sensor may change slightly. Normally, the slope will remain fairly stable during storage.

The MetriNet controller provides two methods for calibrating pH nodes. The first method is a 1-point adjustment which corrects small changes in the zero offset of the sensor. The second method is a 2-point adjustment using 2 buffers (pH 4 and pH 7 recommended). This method corrects both the zero offset and the sensor slope. A 1-point calibration is often sufficient for monthly or bimonthly adjustment. A 2-point calibration should be done at least once a year.

For 1-point calibration, use a pH 7 buffer and proceed as follows:

1. Remove the sensor from the flowcell and place it in a container of pH 7 buffer. Buffer level should be covering the lower third of the sensor.
2. On the MetriNet controller, go the SENSOR Menu and use the ◀ key to select the sensor number for the pH sensor you wish to calibrate. The lower line of the display will default to “Cal pH-s Sx” (x is sensor number). This is the starting point for 1-point calibration.
3. Press Enter and the display will show the measured pH value and the first digit will flash. Use the ▲ key to adjust the digit and the ◀ key to move to the next digit.
4. When the display has been adjusted to 7.00, press Enter. The lower line will flash “Cal Pass” and then will briefly display the slope and zero offset values for the sensor. A “cal fail” message indicates a serious sensor problem and may require replacement of the node. Damage to the glass electrode is the most common reason for calibration failure.

7.42 pH Maintenance

The pH sensitive glass element in the pH M-Node is not replaceable. The silver/silver chloride reference element and corresponding reference junction may be serviced to insure maximum sensor life. Be very careful in handling pH sensors as the glass pH bulb is easily broken if it comes in contact with hard surfaces. The guard around the glass protects it from accidental contact with surfaces. Do not use sharp objects near the glass bulb.

The most common problem with pH electrodes is either slow plugging of the reference junction or contamination of the reference fill solution. Problems in the reference electrode normally show up as calibration drift. If a sensor is constantly drifting in one direction, the most likely cause is a reference electrode issue.

While both electrolyte dilution or junction plugging can cause this problem, the first step is to change the reference solution. The reference solution is actually a gel and a bottle of this gel is supplied with the pH node. To replace this gel, first remove the reference junction from the end of the sensor. Be careful not to damage the glass electrode when doing this. The junction unscrews from the end of the sensor as shown in the drawing below.

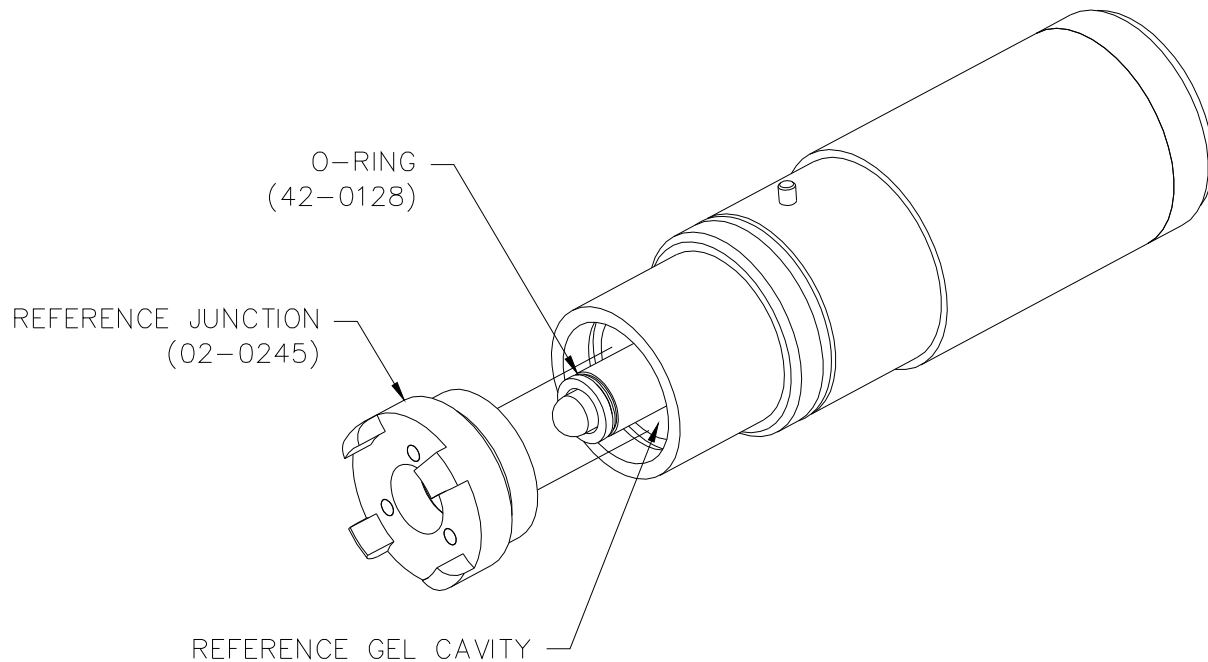

Figure 19 – pH Sensor Reference Assembly

A wash bottle is useful in removing the old gel from the sensor. Fill the wash bottle with distilled water for cleaning out gel. It is not necessary to get it all out. If no wash bottle is available, simply pour distilled water into the cavity repeatedly until most of the gel is gone. Once gel is mostly removed, refill the cavity with fresh reference gel from the container supplied.

Fill the internal cavity until the gel level is just below the red o-ring on the center electrode support and then replace the reference junction ring. Screw the junction onto the body slowly to allow excess gel to vent from the body. The reference junction need only be hand tight. Do not use tools to tighten the junction.

Sensors refilled with reference gel will take some time to restabilize. After this type of service, place the sensor in pH 4 buffer for 1-2 hours. Once placed back into service, allow the sensor to run on sample water for 30 minutes prior to calibration.

7.43 pH Sensor Cleaning

A pH sensor will maintain good stability and accuracy as long as the glass electrode is clean and the reference junction is clear. Over time, deposits or biological slimes can form on the sensor surfaces. Periodic cleaning will be needed and the cleaning frequency will vary depending on water quality.

The method used to clean the sensor will depend on what kind of fouling occurs. By far the most common will be biological growth similar to what you might find on the inside of pipe walls. This kind of fouling is easily removed. It is often sufficient to simply place the end of the sensor under running water to wash off deposits. If that is insufficient, place the sensor in soapy water for 10 minutes and then rinse again under running tap water. If necessary, you can carefully use a Q-tip to gently wipe the surface of the glass bulb.

Deposits of iron or manganese that adhere to the pH sensor will not come off with soap or careful wiping. Those deposits can only be removed using a dilute hydrochloric acid solution. If necessary, immerse the end of the sensor in 0.1 molar HCl solution for 30 minutes. This will dissolve metallic contaminants from the surface of the glass bulb. Rinse with water and run a 2-point calibration after acid cleaning.

7.5 Combined Chlorine M-Node

Combined chlorine nodes employ a membrane covered amperometric sensor that generates a small current proportional to the monochloramine concentration in the sample. On chloraminated water, this sensor provides a total chlorine measurement. Chlorine sensors require installation of a membrane and electrolyte prior to use. A package of membranes and a bottle of electrolyte are supplied with the node. Figure 15 shows an exploded view of that sensor.

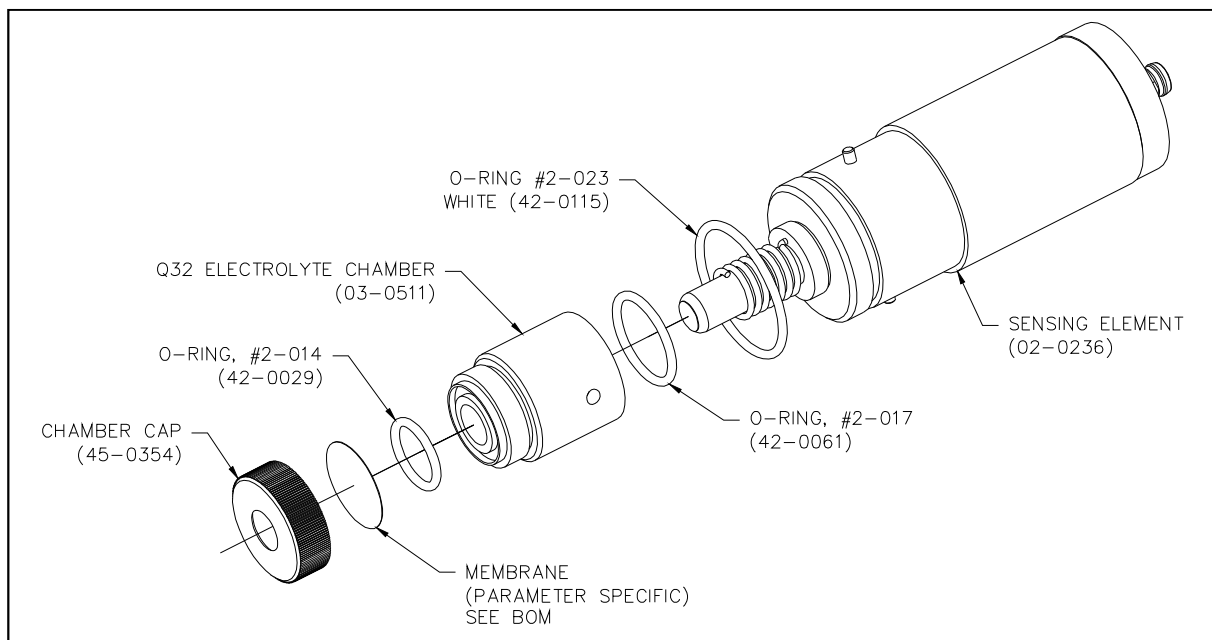

Figure 20 – Chlorine Sensor Exploded View

To prepare the sensor for operation, follow these steps.

1. Unscrew the electrolyte chamber from the node body. If it is filled with electrolyte, discard and rinse with distilled water.
2. Remove the membrane cap and discard the membrane.
3. Remove a new membrane from the membrane container and carefully place it in the bottom of the membrane cap. Be sure your hands are clean before handling membranes. Grease and oil on a membrane will cause measurement failure.

CAUTION: Membranes used for combined chlorine measurement (05-0128) are not the same on both sides. One side is shiny and the other is dull and feels slightly rough. When placing the membrane in the cap, be sure that the shiny side is facing out. The shiny side should be in contact with the measured sample.

4. Screw membrane cap onto electrolyte chamber. Tighten securely and then fill chamber to the middle of the internal threads with electrolyte.
5. Screw the electrolyte chamber onto the node body and tighten firmly. A small amount of electrolyte may come out of the white vent on the side of the chamber. This is normal.

CAUTION: The electrolyte solution is a harmless salt solution. However, those with particularly sensitive skin may wish to wear latex gloves when completing the above procedure. Avoid eye contact with electrolyte. Should eye contact occur, flush for 5 minutes with clean water. Consult a doctor if eye irritation persists.

7.51 Chlorine Span Calibration

Combined chlorine sensing nodes require a short stabilization time. Prior to calibration, install the node in its flow chamber and turn on the sample flow. Connect the sensor to the MetriNet controller and turn on the power. New sensors should be allowed to run for 30-60 minutes prior to calibration. Sensors that have been used for weeks or months will stabilize within 2-4 hours after membrane and electrolyte changes.

NOTE: Chlorine sensors will stabilize without continuous flow of sample. It is enough to fill the flow chamber with water and then shut off flow if desired. The sensor must be connected to a controller with power on for stabilization.

Once the sensor is stable, make sure that sample is flowing for at least 5 minutes prior to calibration. Then follow these steps.

1. Press controller Menu key twice to get to SENSOR on the lower line. After a few seconds, it will change to Cal Chlr Sx (x is sensor #). The numerical display will show the current free chlorine measurement.
2. Observe the display to be sure the chlorine value is not steadily increasing or decreasing. You cannot calibrate on a sample that is constantly changing. The display value should be stable within about 0.2 ppm.
3. Collect a sample of the water coming from the outlet of the flow assembly and use a portable test kit to measure the free chlorine value.
4. Press Enter and the first digit will flash. Use the ▲ key to adjust that digit and then the ◀ key to move to the next digit.
5. Once your display value matches the result of your test kit, press Enter and the sensor will be calibrated and a new "Slope" value calculated.

NOTE: The slope value is meant to be an indicator of sensor condition. The absolute value is not particularly critical. The best use of this number is to see how the calibration has changed since the last calibration. Prior to calibration, go to the MEASURE Menu and check the current slope value. Compare that value to the new value calculated after a calibration. As an example, your system has a slope of 125% prior to calibration. After calibration, the new slope is 113%. During the interval between the first and second calibrations, the sensitivity has changed by 12/125 or about 10%. This information can help in determining the frequency of calibration required for a given site.

7.52 Chlorine Zero Calibration

Chlorine sensors have very low offsets and very good zero stability. Zero adjustment is normally not required. It is possible to check and adjust the zero if you wish. Follow these steps.

1. With the sensor connected to the controller and the controller powered up, remove the sensor from the flowcell and rinse with distilled water.
2. Place the sensor in a small container of distilled water so that the bottom half of the sensor is covered.
3. Allow the sensor to sit undisturbed for 15 minutes. In almost all cases, the display will be reading 0.01 or less.
4. To adjust zero, go to “Sensor” and then press ▲ until the lower line reads “Cal Zero Sx”.
5. Press Enter and wait for a few seconds. Then press Enter again and the zero will be updated.

7.53 Chlorine Maintenance

Chlorine sensors use a microporous membrane that can accumulate coatings from iron, manganese, and other particulates in the water. The rate at which this occurs is highly variable. Some applications have run for 1 year without a membrane change while other struggle to get to 1 month on a membrane. There is no way to predict this and only experience at each location will answer the question of how often membranes should be changed. In the previous section, there is a note on “Slope”. The rate of change of the slope value observed after each calibration can give you an idea as to how long a membrane will last.

That slope value change will also give you an indication as to how often calibration is even necessary. For example, you install a chlorine node at a site and do an initial calibration. The slope is 110%. You come back to recalibrate 2 weeks later and the slope is 108%. This 2% change is probably within the error of your test kit. In essence, the sensitivity of your sensor did not change in 2 weeks. Clearly, a calibration every 2 weeks is not needed. Extend the interval to 1 month and repeat the test. From experience, many installations require calibration no more than every 2-3 months and some are much longer.

When maintenance is required, which is indicated by a slope value dropping to less than 50% of its value after the first calibration, the membrane and electrolyte should be changed. Repeat the procedure outlined in section 7.5.

7.6 ORP M-Node

The ORP Node is an assembly that uses a Platinum ORP electrode with a Pt1000 temperature element. The Modbus electronic interface is potted into the back of the assembly. The overall measuring range of this device is 0-1000 mv. The ORP measurement nodes are expected to have a 2-5 year life in normal service.

7.61 ORP Calibration

Calibration of ORP M-Nodes requires a 1-point calibration, which establishes the “zero offset” for the sensor. An initial calibration of each sensor is done at the factory using 600 mv standard ORP solution. Depending on the time period between when a sensor was shipped and when it is put into service, the zero offset of the sensor may change slightly. It is not necessary (or even possible) to calibrate the slope of an ORP sensor. ORP sensors simply measure the bulk electrochemical charge in a sample expressed in millivolts. By definition, the slope is always 100%.

The MetriNet controller provides a simple 1-point calibration method but requires that the user obtain an ORP standard solution. Standard solutions of either 200 mv. or 600 mv. are available from ATI. ORP standards are also available from most laboratory supply houses.

For 1-point calibration, use a 600 mv. or other ORP standard and proceed as follows:

1. Remove the sensor from the flowcell and place it in a container of 600 mv. standard solution. Solution level should be covering the lower third of the sensor.
2. On the MetriNet controller, go the SENSOR Menu and use the ◀ key to select the sensor number for the pH sensor you wish to calibrate. The lower line of the display will default to “Cal ORP-s Sx” (x is sensor number). This is the starting point for 1-point calibration.
3. Press Enter and the display will show the measured ORP value and the first digit will flash. Use the ▲ key to adjust the digit and the ◀ key to move to the next digit.
4. When the display has been adjusted to 600, press Enter. The lower line will flash “Cal Pass” and then will briefly display the slope and zero offset values for the sensor. A “cal fail” message indicates a serious sensor problem and may require replacement of the node. Damage to the platinum electrode or contamination of the reference electrode are the two possible reasons for calibration failure.

7.62 ORP Maintenance

The platinum sensing element in the ORP M-Node is not replaceable. The silver/silver chloride reference element and corresponding reference junction may be serviced to insure maximum sensor life. Be careful in handling ORP sensors as the platinum electrode needs to remain clean and free of contamination. The guard around the platinum element protects it from accidental contact with surfaces. Never try to clean the platinum electrode with an abrasive material containing metal.

The most common problem with ORP electrodes is either slow plugging of the reference junction or contamination of the reference fill solution. Problems in the reference electrode normally show up as calibration drift. If a sensor is constantly drifting in one direction, the most likely cause is a reference electrode issue.

While both electrolyte dilution or junction plugging can cause this problem, the first step is to change the reference solution. The reference solution is actually a gel and a bottle of this gel is supplied with the pH node. To replace this gel, first remove the reference junction from the end of the sensor. Be careful not to damage the glass electrode when doing this. The junction unscrews from the end of the sensor as shown in the drawing below.

A wash bottle is useful in removing the old gel from the sensor. Fill the wash bottle with distilled water for cleaning out gel. It is not necessary to get it all out. If no wash bottle is available, simply pour distilled water into the cavity repeatedly until most of the gel is gone. Once gel is mostly removed, refill the cavity with fresh reference gel from the container supplied.

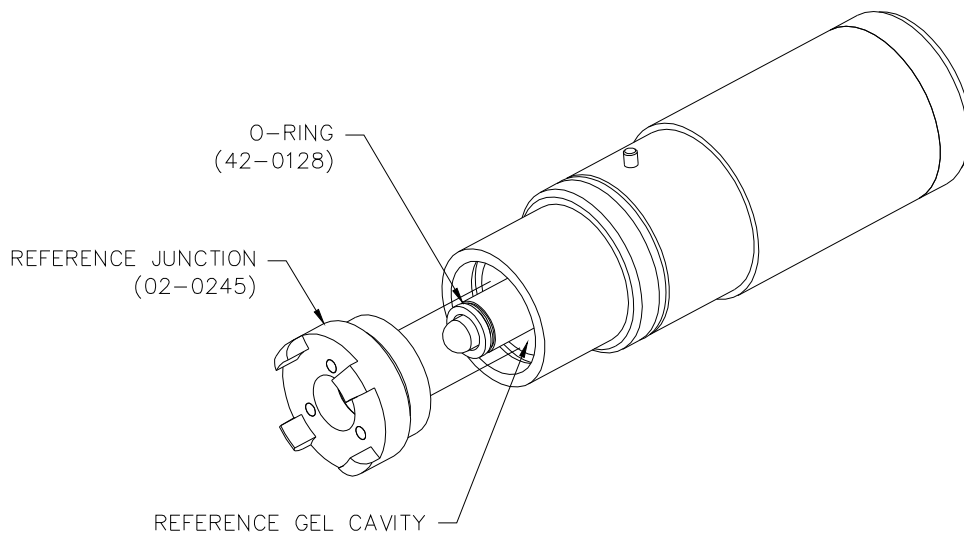

Figure 21 – ORP Sensor Reference Assembly

Fill the internal cavity until the gel level is just below the red o-ring on the center electrode support and then replace the reference junction ring. Screw the junction onto the body slowly to allow excess gel to vent from the body. The reference junction need only be hand tight. Do not use tools to tighten the junction.

Sensors refilled with reference gel will take some time to restabilize. After this type of service, place the sensor in pH 4 buffer for 1-2 hours. Once placed back into service, allow the sensor to run on sample water for 30 minutes prior to calibration.

7.63 ORP Sensor Cleaning

An ORP sensor will maintain good stability and accuracy as long as the platinum electrode is clean and the reference junction is clear. Over time, deposits or biological slimes can form on the sensor surfaces. Periodic cleaning will be needed and the cleaning frequency will vary depending on water quality.

The method used to clean the sensor will depend on what kind of fouling occurs. By far the most common will be biological growth similar to what you might find on the inside of pipe walls. This kind of fouling is easily removed. It is often sufficient to simply place the end of the sensor under running water to wash off deposits. If that is insufficient, place the sensor in soapy water for 10 minutes and then rinse again under running tap water. If necessary, you can carefully use a Q-tip to gently wipe the surface of the platinum sensing element.

Deposits of iron or manganese that adhere to the ORP sensor will not come off with soap or careful wiping. Those deposits can only be removed using a dilute hydrochloric acid solution. If necessary, immerse the end of the sensor in 0.1 molar HCl solution for 30 minutes. This will dissolve metallic contaminants from the surface of the sensor. Rinse with water and run a 2-point calibration after acid cleaning.

7.7 Turbidity M-Node

The node used for turbidity measurement is an optical assembly that uses an infra-red LED sensor with standard 90° light scatter measurement method. Because the sensor has been miniaturized and the volume of the flowcell greatly reduced, very low turbidity measurements (less than 0.2 NTU) will show some variability that might not be seen with a large volume, high power turbidity systems. However, the sensor provides reliable tracking and is extremely useful in detecting turbidity spikes in the distribution system.

7.71 Turbidity Span Calibration

Turbidity M-Nodes are factory calibrated using 20 NTU standards. It is not normally necessary to calibrate a turbidity node at the time of startup. However, calibration can be checked and adjusted if desired.

In order to calibrate, or check calibration, you will need to obtain turbidity standards in the 10-40 NTU range. Standards below 10 NTU are not recommended due to stability issues. Standards of 20 or 40 NTU are relatively easy to mix by dilution of 4000 NTU stock solution available from ATI.

There are two methods for immersing the turbidity sensor in standards. The simplest is to use the rubber cap supplied with the sensor. This black cap is optically similar to the flowcell. Pour turbidity standard into the flowcell almost to the top and then carefully push the end of the turbidity sensor into the cap, trying to be sure that all air is forced out. If it's convenient, disconnect the turbidity sensor while doing this. It can be a little messy so do it over a sink. Once the sensor is in contact with the standard, plug it back into the MetriNet controller and allow the reading to stabilize for 5 minutes.

The second method is to fill the flowcell with standard. This requires a syringe and a short piece of tubing for connection to the MetriNet flowcells. First, stop flow to the flow system and disconnect the inlet tube. Connect the tubing to the syringe and place the end of the tubing into your mixed standard. Pull the plunger to fill the syringe with standard and then connect the end of the tube to the inlet fitting at the bottom of the flow assembly. It is best to have the turbidity sensor located in the first or second flow chamber if there are more than 2 chambers in the assembly. Push in the syringe plunger to fill the lower flow chambers. About 30 ml. is enough to fill them. Allow the turbidity reading to stabilize for 5 minutes.

To calibrate, proceed as follows:

1. Press controller Menu key twice to get to SENSOR on the lower line. After a few seconds, it will change to Cal Turb Sx (x is sensor #). The numerical display will show the current free chlorine measurement.
2. Observe the display to be sure the turbidity value is reasonably stable. It may be changing by a few hundredths but should not be steadily increasing or decreasing. The display value should be stable to 0.1 NTU.
3. Press Enter and the first digit will flash. Use the ▲ key to adjust that digit and then the ◀ key to move to the next digit.
4. Once your display value matches the value of the standard you are using, press Enter and the sensor will be calibrated and a new "Slope" value calculated.

7.72 Turbidity Zero Calibration

Turbidity sensors are zeroed at the factory. These sensors are set to a zero turbidity value on a sample running through a 0.2 micron filter for 15-30 minutes. It is generally not necessary to adjust the zero of this sensor. The only way that this can be done is by duplicating the factory conditions. That means running sample through a high quality 0.2 micron filter for an extended period of time. Using this method, it is possible to check and adjust the zero if you wish. Follow these steps.

1. With the sensor connected to the controller and the controller powered up, connect a 0.2 micron or finer filter to the inlet tubing feeding sample to the flowcell assembly.
2. Allow filtered water to run continuously for 30 minutes.
3. To adjust zero, go to “Sensor” and then press ▲ until the lower line reads “Cal Zero Sx”.
4. Press Enter and wait for a few seconds. Then press Enter again and the zero will be updated.

7.73 Turbidity Maintenance

The only maintenance required on a turbidity sensor is cleaning. Deposits may build up on the surface of the sensor over time and those deposits can affect the measurement. Wiping with a soft cloth is all that's needed.

CAUTION: Do not use any abrasive materials on the turbidity sensor or optical lenses may be destroyed.

Spraying the end of the sensor with a household surface cleaner like “Fantastik” and then wiping with a soft cloth will remove most deposits. Should the surface become fouled with iron and manganese precipitation, soaking for 30 minutes in a solution of “Red-B-Gone” (<http://red-b-gone.com>) is extremely effective.

The turbidity sensor contains a self-checking feature designed to detect optical fouling and indicate to operators that cleaning is needed. On the lower line of the display in the MEASURE menu for the turbidity sensor, you will see a “sig XX%” message. The XX will be what we refer to as the check signal value. After a sensor is installed and the system has been operating for an hour or so, that value will probably be something above 80%.

The absolute value is not critical but it is a good idea to record that value. If you want, you can force it to 100% in the SENSOR menu. Over time, that value will go down as the optical surfaces get dirty. You can set an alarm value for that parameter in the SENSOR menu. An alarm at 50% is suggested. When the signal value falls to that level, the sensor should be removed and wiped clean.

7.8 Dissolved Oxygen M-Node

Dissolved Oxygen nodes employ a membrane covered amperometric sensor that generates a small current proportional to the partial pressure of oxygen in solution. The D.O. node is suitable for use on all water samples and provides interference free measurement. The D.O. sensor requires installation of a membrane and electrolyte prior to use. A package of membranes and a bottle of electrolyte are supplied with the node. Figure 15 shows an exploded view of that sensor.

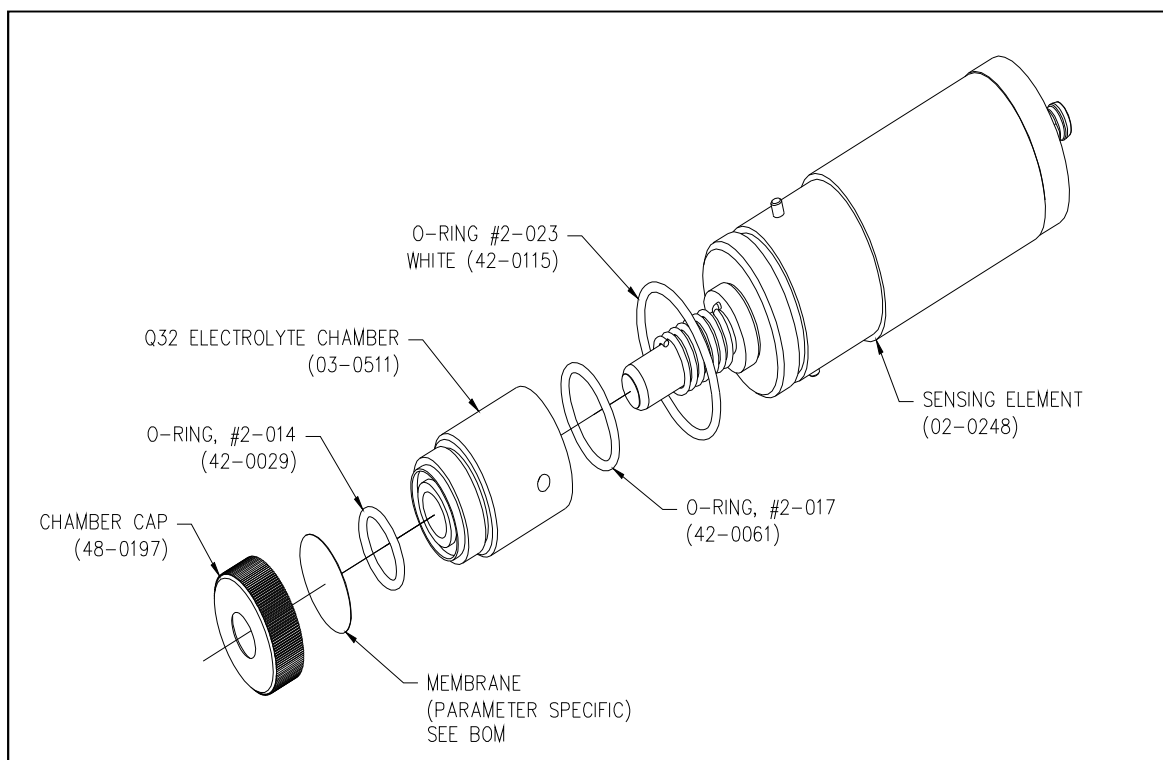

Figure 22 – D.O. Sensor Exploded View

To prepare the sensor for operation, follow these steps.

1. Unscrew the electrolyte chamber from the node body. If it is filled with electrolyte, discard and rinse with distilled water.
2. Remove the membrane cap and discard the membrane.
3. Remove a new membrane from the membrane container and carefully place it in the bottom of the membrane cap. Membranes are thin clear plastic with paper separators. Be sure your hands are clean before handling membranes. Grease and oil on a membrane will cause measurement failure.
4. Screw membrane cap onto electrolyte chamber. Tighten securely and then fill chamber to the middle of the internal threads with electrolyte.
5. Screw the electrolyte chamber onto the node body and tighten firmly. A small amount of electrolyte may come out of the white vent on the side of the chamber. This is normal.

CAUTION: The electrolyte solution is a harmless salt solution. However, those with particularly sensitive skin may wish to wear latex gloves when completing the above procedure. Avoid eye contact with electrolyte. Should eye contact occur, flush for 5 minutes with clean water. Consult a doctor if eye irritation persists.

7.81 D.O. Span Calibration

D.O. sensing nodes require a short stabilization time. Stabilization will occur as long as power is applied. The node does not need to be in water to stabilize. It will respond to oxygen gas in the air and will be ready for use approximately 30 minutes after power is applied.

Span calibration for a D.O. sensor is done using ambient air as a reference. The partial pressure of oxygen in ambient air is the same as that found in oxygen saturated water. For proper span adjustment, the sensor must be at the same temperature as the surrounding air. If necessary, let the sensor come to ambient temperature before adjustment and then follow these steps. The sensor temperature is one of the lower line displays you can access.

1. Press controller Menu key twice to get to SENSOR on the lower line. After a few seconds, it will change to Cal D.O. Sx (x is sensor #). The numerical display will show the current dissolved oxygen measurement.
2. Observe the display to be sure the D.O. value is not steadily increasing or decreasing. You cannot calibrate if the value is constantly changing. The display value should be stable within about 0.1 ppm.
3. Refer to the saturation table below to find the D.O. value for your sensor temperature. Press Enter and the first digit will flash. Use the ▲ key to adjust that digit and then the ◀ key to move to the next digit. Once your display value matches the saturation value, press Enter and the sensor will be calibrated and a new “Slope” value calculated.

NOTE: The slope value is meant to be an indicator of sensor condition. The absolute value is not particularly critical. The best use of this number is to see how the calibration has changed since the last calibration. Prior to calibration, go to the MEASURE Menu and check the current slope value. Compare that value to the new value calculated after a calibration. As an example, your system has a slope of 125% prior to calibration. After calibration, the new slope is 113%. During the interval between the first and second calibrations, the sensitivity has changed by 12/125 or about 10%. This information can help in determining the frequency of calibration required for a given site.

Water Saturated Concentration of O ₂					
Temperature		PPM	Temperature		PPM
°F	°C		°F	°C	
32	0.0	14.6	74	23.3	8.5
34	1.1	14.1	76	24.4	8.3
36	2.2	13.7	78	25.6	8.2
38	3.3	13.3	80	26.7	8.0
40	4.4	12.9	82	27.8	7.8
42	5.6	12.6	84	28.9	7.7
44	6.7	12.2	86	30.0	7.5
46	7.8	11.9	88	31.1	7.4
48	8.9	11.6	90	32.2	7.3
50	10.0	11.3	92	33.3	7.1
52	11.1	11.0	94	34.4	7.0
54	12.2	10.7	96	35.6	6.9
56	13.3	10.4	98	36.7	6.8
58	14.2	10.2	100	37.8	6.6
60	15.6	9.9	102	38.9	6.5
62	16.7	9.7	104	40.0	6.4
64	17.8	9.5	106	41.1	6.3
66	18.9	9.3	108	42.2	6.2
68	20.0	9.1	110	43.3	6.1
70	21.1	8.9	112	44.4	6.0
72	22.2	8.7	114	45.6	5.9

Figure 23 – D.O. Saturation Table

7.82 D.O. Zero Calibration

D.O. sensors have very low offsets and very good zero stability. Zero adjustment is normally not required. It is possible to check and adjust the zero if you wish. To check the zero, you will need to use sodium sulfite or sodium bisulfite to remove the dissolved oxygen from a container of water. Follow these steps.

1. With the sensor connected to the controller and the controller powered up, remove the sensor from the flowcell and rinse with distilled water.
2. Fill a small container with enough water to cover the lower half of the sensor. Add about ½ teaspoon of sodium sulfite to the container and swirl. This will remove the D.O. and give you a zero reference.
3. Place the sensor in the container and allow the sensor to sit undisturbed for about 10 minutes. You will see the displayed D.O. value drop quickly and will normally reach 0.00 ± 0.02 ppm in that time. If it does, do not bother to adjust the zero. If you do wish to make a minor adjustment, proceed as follows.
4. To adjust zero, go to “Sensor” and then press ▲ until the lower line reads “Cal Zero Sx”.
5. Press Enter and wait for a few seconds. Then press Enter again and the zero will be updated.

7.83 D.O. Maintenance

D.O. sensors use a solid plastic membrane that resists fouling from most components of a water stream. Coatings from iron, manganese, or other materials are possible but are not common. D.O. membranes will normally last at least 6-12 months. A good preventive maintenance practice is to change the D.O. sensor membrane and electrolyte once a year, even if the sensor is still operating normally.

Low dissolved oxygen measurements can be caused by a slow accumulation of material on the membrane. Should a D.O. sensor accumulate a biological slime or other soft coating, simply wipe the membrane with a soft cloth or paper towel. No other maintenance is needed for D.O. sensors.

7.9 Total Chlorine M-Node

Total chlorine nodes employ a membrane covered amperometric sensor that generates a small current proportional to the concentration of chlorine in the sample. Total chlorine sensors use a composite membrane cap assembly. A cap is included in the sensor and a package of two spare membrane caps are supplied along with a bottle of electrolyte and an o-ring kit. New total chlorine sensors are shipped dry and require addition of electrolyte prior to use. Below is a drawing showing an exploded view of the total chlorine sensor.

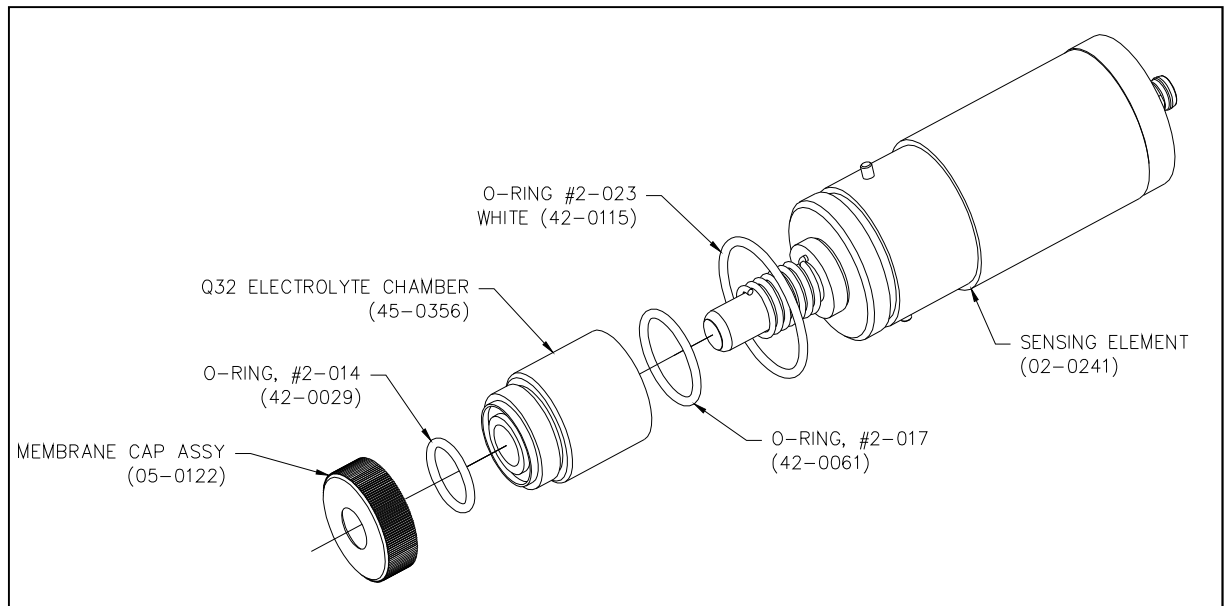

Figure 24 - TC12 Sensor Exploded View

To prepare the sensor for operation, follow these steps.

1. Unscrew the electrolyte chamber from the node body. If it is filled with electrolyte, discard and rinse with distilled water. New sensors do not contain electrolyte.

NOTE: If servicing a sensor that's been in use, remove the old membrane cap and replace it with a new one.

2. Fill the electrolyte chamber with 09-0089 electrolyte to about the middle of the internal threads.
3. Screw the electrolyte chamber onto the node body and tighten firmly. A small amount of electrolyte may come out of the white vent on the side of the chamber. This is normal.

NOTE: The electrolyte solution is a harmless salt solution. However, those with particularly sensitive skin may wish to wear latex gloves when completing the above procedure. Avoid eye contact with electrolyte. Should eye contact occur, flush for 5 minutes with clean water. Consult a doctor if eye irritation persists.

7.91 Chlorine Span Calibration

Total chlorine sensing nodes require a fairly long stabilization time. Prior to calibration, install the node in its flow chamber and turn on the sample flow. Connect the sensor to the MetriNet controller and turn on the power. New sensors should be allowed to run for 4-8 hours prior to calibration. Sensors that have been used for weeks or months will stabilize within 2-4 hours after membrane and electrolyte changes.

NOTE: Chlorine sensors will stabilize without continuous flow of sample. It is enough to fill the flow chamber with water and then shut off flow if desired. The sensor must be connected to a controller with power on for stabilization.

Once the sensor is stable, make sure that sample is flowing for at least 5 minutes prior to calibration. Then follow these steps.

1. Press controller Menu key twice to get to SENSOR on the lower line. After a few seconds, it will change to Cal Chlr Sx (x is sensor #). The numerical display will show the current free chlorine measurement.
2. Observe the display to be sure the chlorine value is not steadily increasing or decreasing. You cannot calibrate on a sample that is constantly changing. The display value should be stable within about 0.2 ppm.
3. Collect a sample of the water coming from the outlet of the flow assembly and use a portable test kit to measure the free chlorine value.
4. Press Enter and the first digit will flash. Use the ▲ key to adjust that digit and then the ◀ key to move to the next digit. Once your display value matches the result of your test kit, press Enter and the sensor will be calibrated and a new "Slope" value calculated.

NOTE: The slope value is meant to be an indicator of sensor condition. The absolute value is not particularly critical. The best use of this number is to see how the calibration has changed since the last calibration. Prior to calibration, go to the MEASURE Menu and check the current slope value. Compare that value to the new value calculated after a calibration. As an example, your system has a slope of 125% prior to calibration. After calibration, the new slope is 113%. During the interval between the first and second calibrations, the sensitivity has changed by 12/125 or about 10%. This information can help in determining the frequency of calibration required for a given site.

7.92 Chlorine Zero Calibration

Chlorine sensors have very low offsets and very good zero stability. Zero adjustment is normally not required. It is possible to check and adjust the zero if you wish. Follow these steps.

1. With the sensor connected to the controller and the controller powered up, remove the sensor from the flowcell and rinse with distilled water.
2. Place the sensor in a small container of distilled water so that the bottom half of the sensor is covered.
3. Allow the sensor to sit undisturbed for 15 minutes. In almost all cases, the display will be reading 0.01 or less.

4. To adjust zero, go to “Sensor” and then press ▲ until the lower line reads “Cal Zero Sx”.
5. Press Enter and wait for a few seconds. Then press Enter again and the zero will be updated.

7.93 Chlorine Maintenance

Chlorine sensors use a microporous membrane that can accumulate coatings from iron, manganese, and other particulates in the water. The rate at which this occurs is highly variable. Some applications have run for 1 year without a membrane change while other struggle to get to 1 month on a membrane. There is no way to predict this and only experience at each location will answer the question of how often membranes should be changed. In the previous section, there is a note on “Slope”. The rate of change of the slope value observed after each calibration can give you an idea as to how long a membrane will last.

That slope value change will also give you an indication as to how often calibration is even necessary. For example, you install a chlorine node at a site and do an initial calibration. The slope is 110%. You come back to recalibrate 2 weeks later and the slope is 108%. This 2% change is probably within the error of your test kit. In essence, the sensitivity of your sensor did not change in 2 weeks. Clearly, a calibration every 2 weeks is not needed. Extend the interval to 1 month and repeat the test. From experience, many installations require calibration no more than every 2-3 months and some are much longer.

When maintenance is required, which is indicated by a slope value dropping to less than 50% of its value after the first calibration, the membrane and electrolyte should be changed. Repeat the procedure outlined in section 7.5.

7.10 Fluoride M-Node

The Fluoride Node is an assembly that uses a rebuildable combination FI⁻ electrode with a Pt1000 temperature element. The Modbus electronic interface is potted into the back of the assembly. The overall measuring range of this device is 0.1-10.0 mg/l. These Fluoride measurement nodes are expected to have a 2-5 year life in normal service. The reference half of the combination sensor is refillable and the reference junction is replaceable.

Sophisticated fluoride monitors are normally chemistry systems that adjust the sample pH and ionic strength to optimize fluoride sensor performance. This is not practical for remote site monitoring and users are advised that both sample pH and conductivity changes can influence the fluoride reading. If these variables are fairly constant, fluoride readings will be reliable. If site conditions can include large pH changes (>1 pH unit) or significant changes in conductivity (uS values changing by more than 25%), fluoride values may deviate from actual values by up to 0.4 ppm. Fluoride nodes may not be useful in such conditions.

7.101 Fluoride Calibration

Fluoride sensors are much like pH sensors in that they need a 2-point calibration to establish the slope of the sensor. The slope adjustment for fluoride nodes is done at the factory prior to shipment using 1 and 10 ppm fluoride standards mixed in tap water. With the slope already established, it is often sufficient to do a 1-point calibration against a test kit or lab measurement. A 2-point slope calibration may also be done if desired.

Note: 1-point fluoride calibration should only be done using a sample taken from the water system where the sensor is installed. Do not use a mixed standard that has a different ionic matrix (ie. Distilled water).

For a 1-point calibration, proceed as follows:

1. Remove the sensor from the flowcell and place it in a sample with a known fluoride concentration. The concentration must be between 0.5 and 10 ppm. Sample level should cover the lower third of the sensor.
2. On the MetriNet controller, go the SENSOR Menu and use the ◀ key to select the sensor number for the FI⁻ sensor. The lower line of the display will default to "Cal FI-s Sx" (x is sensor number). This is the starting point for 1-point calibration.
3. Press Enter and the display will show the measured fluoride value and the first digit will flash. Use the ▲ key to adjust the digit and the ◀ key to move to the next digit.
4. When the display has been adjusted to the known fluoride value, press Enter. The lower line will flash "Cal Pass" and then will briefly display the slope and zero offset values for the sensor. A "cal fail" message indicates a serious sensor problem and may require replacement of the node. Damage to the fluoride crystal on the tip of the electrode is the most common reason for calibration failure.

A **2-point calibration** to establish the response slope of the sensor is a bit more involved as it requires of 2 fluoride standards, but is not difficult. The most important requirement is that you have two standards one decade apart in concentration. Recommended is either 1 ppm & 10 ppm or 0.5 ppm & 5 ppm. These standards can either be purchased or mixed in the lab.

For a 2-point calibration, proceed as follows. The procedure assumes the use of 1 and 10 ppm standards.

1. Remove the sensor from the flowcell and place it in a container of 1 ppm standard. Solution level should be covering the lower third of the sensor.
2. On the MetriNet controller, go the SENSOR Menu and use the ◀ key to select the sensor number for the FI sensor.
3. Press the ▲ key once and the lower line display will indicate “Cal FI-1 Sx” (x is the sensor number).
4. When the fluoride value is stable, press Enter. The first digit will begin to flash. Use the ▲ key to adjust the first digit and the ◀ to move to the next digit. Set the display to pH 01.00 and then press Enter. The “accepted” message will display briefly.
5. Press the ▲ key once. Lower line will indicate “Cal FI-2 Sx”. Remove the sensor from the 1 ppm solution, rinse with clean water, and place in a container of 10 ppm fluoride standard.
6. Allow the pH reading to stabilize for a minute or two. After the display is stable, press Enter and the first digit will flash. Adjust the display to a value of 10.00 ppm and then press Enter.
7. After establishing the slope with this procedure, place the sensor in the flowcell and complete a 1-point process calibration.

7.102 Fluoride Maintenance

The sensing element in a fluoride node is a lanthanum fluoride crystal on the tip of the sensor and it is not replaceable. The silver/silver chloride reference element and corresponding reference junction may be serviced to insure maximum sensor life. Be careful in handling fluoride sensors as the sensing crystal is easily scratched. The reference junction assembly protects it from accidental contact with surfaces. Never try to clean the fluoride electrode with an abrasive material.

The most common problem with fluoride electrodes is either slow plugging of the reference junction or contamination of the reference fill solution. Problems in the reference electrode normally show up as calibration drift. If a sensor is constantly drifting in one direction, the most likely cause is a reference electrode issue.

If problems occur, the first step is to change the reference solution. The reference solution is actually a gel and a bottle of this gel is supplied with the node. To replace this gel, first remove the reference junction from the end of the sensor. Be careful not to damage the fluoride element when doing this. The junction unscrews from the end of the sensor as shown in the drawing below.

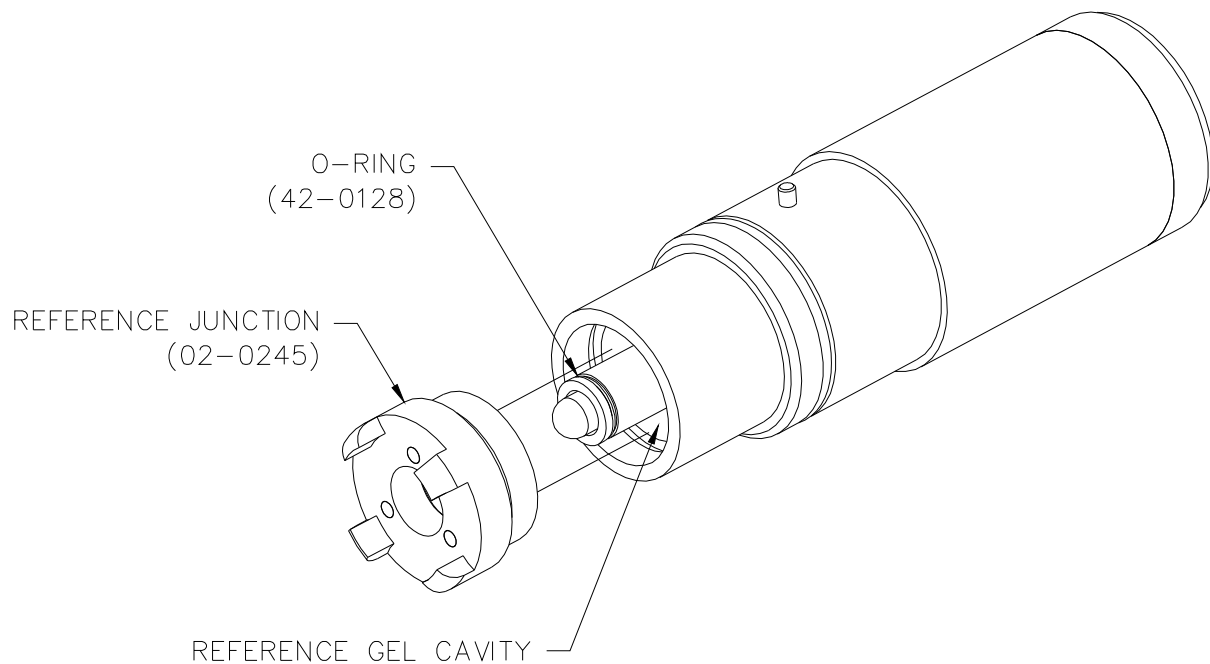

Figure 25 – Fluoride Node Exploded View

A wash bottle is useful in removing the old gel from the sensor. Fill the wash bottle with distilled water for cleaning out gel. It is not necessary to get it all out. If no wash bottle is available, simply pour distilled water into the cavity repeatedly until most of the gel is gone. Once gel is mostly removed, refill the cavity with fresh reference gel from the container supplied. If sensor drift continues, replace the reference junction.

The fluoride sensitive crystal at the tip of the sensor can be carefully wiped with a soft cotton cloth or Q-tip. If deposits do not wipe off readily, the sensor can be immersed in 0.1 N hydrochloric acid to remove iron or manganese contamination. Always do a 2-point slope calibration after cleaning the sensor tip or doing any maintenance on the reference element.

7.11 Pressure M-Node

The pressure node for the MetriNet system is intended to allow users to monitor pressure at either the inlet to the sensor flow system or line pressure in the pipe feeding sample to the system. The pressure at these two points are not always the same. The MetriNet flow system is limited to about 50 PSI and a pressure reducing valve may be installed between the main line and the flow system. The pressure node is usable for monitoring up to 300 PSIG and can be installed between the main water line and the pressure reducing valve for monitoring system pressure.

Refer to Figure 8 on page 16 of this manual for a diagram of this type of installation. When pressure nodes are installed remote from the flowcell system, a separate bus connection cable will be needed as the standard cables are only 12" long. The standard interconnecting cable for this type of application is 9.75 ft (3 m) and is available from ATI.



Figure 26 - Pressure Sensor

Pressure M-Nodes do not require maintenance. Calibration can be done if desired by is normally not required.

Spare Parts

<u>Part No.</u>	<u>Description</u>
-----------------	--------------------

Electronics

00-1795	MetriNet Controller, 12-24 VDC with SD Card
00-1811	MetriNet Controller, 12V Battery with SD Card
00-1796	MetriNet Controller, 12-24 VDC with SD Card & Modem
00-1812	MetriNet Controller, 12V Battery with SD Card & Modem
00-1885	MetriNet Controller, 12-24 VDC with SD Card & Modbus RTU
00-1891	MetriNet Controller, 12-24 VDC with Ethernet/IP
36-0067	Latching solenoid valve, 12 VDC

Spare Sensors

00-1733	Free Chlorine M-Node, 0-5.00 ppm
00-1734	Conductivity M-Node, 0-2000 uS
00-1735	pH M-Node, 2-12 pH
00-1736	ORP M-Node, 0-1000 mv.
00-1737	Dissolved Oxygen M-Node, 0-20.00 ppm
00-1738	Dissolved Ozone M-Node, 0-5.00 ppm
00-1739	Turbidity M-Node, 0-40.00
00-1758	Combined Chlorine M-Node, 0-5.00 ppm
00-1780	Total Chlorine M-Node, 0-5.00 ppm
00-1781	Fluoride M-Node, 0.1-10.00 ppm
00-1782	Chlorine Dioxide M-Node, 0-5.00 ppm

Spare Sensor Components

03-0511	Electrolyte chamber, Q32 Sensors
05-0121	Q32 Electrolyte Chamber o-ring kit (3 each 42-0029 and 42-0061)
45-0354	Membrane Cap
48-0197	Membrane holder, titanium (for DO ₂ and DO ₃ sensors)
05-0120	Free chlorine membranes, pkg. of 10
05-0128	Combined chlorine membranes, pkg. of 10
05-0122	Total Chlorine membrane cap, pkg. of 2
09-0011	Free chlorine electrolyte, 60 ml.
09-0010	Combined chlorine electrolyte, 60 ml.
09-0089	Total chlorine electrolyte, 60 ml.
09-0091	pH/ORP/FI ⁻ Reference gel
02-0245	pH/ORP/FI ⁻ Reference Junction
05-0135	D.O. membrane, 2-mil, pkg. of 10
09-0090	D.O. electrolyte, 60 ml.

Flow System

45-0332	Flow chamber only
45-0335	Flow chamber connector ring
03-0490	Flow assembly outlet fitting, no flow regulator, 90° fitting
03-0491	Flow assembly outlet with flow regulator, 90° fitting
05-0130	MetriNet o-ring kit (5 each of flowcell o-ring & M-Node o-ring)
44-0290	Inlet fitting, 1/8" MNPT x 1/4" O.D. tube
44-0269	Outlet fitting, 1/8" MNPT x 1/4" O.D. tube elbow

Cable Assemblies

31-0202	Node to bus bar cable, 12" (30 cm)
31-0204	Q52 to bus bar cable, 155" (4 m)
31-0208	Q52 power supply cable, 12" (30 cm)
31-0212	Bus bar jumper cable, 18" (46 cm)

Misc Components

44-0260	Pg9 Cord Grip (each)
44-0009	Pg11 Cord Grip (each)

PRODUCT WARRANTY

Analytical Technology, Inc. (Manufacturer) warrants to the Customer that if any part(s) of the Manufacturer's equipment proves to be defective in materials or workmanship within the earlier of 18 months of the date of shipment or 12 months of the date of start-up, such defective parts will be repaired or replaced free of charge. Inspection and repairs to products thought to be defective within the warranty period will be completed at the Manufacturer's facilities in Collegetown, PA. Products on which warranty repairs are required shall be shipped freight prepaid to the Manufacturer. The product(s) will be returned freight prepaid if it is determined by the manufacturer that the part(s) failed due to defective materials or workmanship.

This warranty does not cover consumable items, batteries, or wear items subject to periodic replacement including lamps and fuses.

Gas sensors carry a 12 months from date of shipment warranty and are subject to inspection for evidence of misuse, abuse, alteration, improper storage, or extended exposure to excessive gas concentrations. Should inspection indicate that sensors have failed due to any of the above, the warranty shall not apply.

The Manufacturer assumes no liability for consequential damages of any kind, and the buyer by acceptance of this equipment will assume all liability for the consequences of its use or misuse by the Customer, his employees, or others. A defect within the meaning of this warranty is any part of any piece of a Manufacturer's product which shall, when such part is capable of being renewed, repaired, or replaced, operate to condemn such piece of equipment.

This warranty is in lieu of all other warranties (including without limiting the generality of the foregoing warranties of merchantability and fitness for a particular purpose), guarantees, obligations or liabilities expressed or implied by the Manufacturer or its representatives and by statute or rule of law.

This warranty is void if the Manufacturer's product(s) has been subject to misuse or abuse, or has not been operated or stored in accordance with instructions, or if the serial number has been removed.

Analytical Technology, Inc. makes no other warranty expressed or implied except as stated above.

WATER QUALITY MONITORS

Dissolved Oxygen
Free Chlorine
Combined Chlorine
Total Chlorine
Residual Chlorine Dioxide
Potassium Permanganate
Dissolved Ozone
pH/ORP
Conductivity
Hydrogen Peroxide
Peracetic Acid
Dissolved Sulfide
Residual Sulfite
Fluoride
Dissolved Ammonia
Turbidity
Suspended Solids
Sludge Blanket Level
MetriNet Distribution Monitor

GAS DETECTION PRODUCTS

NH ₃	Ammonia
CO	Carbon Monoxide
H ₂	Hydrogen
NO	Nitric Oxide
O ₂	Oxygen
CO	Cl ₂ Phosgene
Br ₂	Bromine
Cl ₂	Chlorine
ClO ₂	Chlorine Dioxide
F ₂	Fluorine
I ₂	Iodine
H _x	Acid Gases
C ₂ H ₄ O	Ethylene Oxide
C ₂ H ₆ O	Alcohol
O ₃	Ozone
CH ₄	Methane (Combustible Gas)
H ₂ O ₂	Hydrogen Peroxide
HCl	Hydrogen Chloride
HCN	Hydrogen Cyanide
HF	Hydrogen Fluoride
H ₂ S	Hydrogen Sulfide
NO ₂	Nitrogen Dioxide
NO _x	Oxides of Nitrogen
SO ₂	Sulfur Dioxide
H ₂ Se	Hydrogen Selenide
B ₂ H ₆	Diborane
GeH ₄	Germane
AsH ₃	Arsine
PH ₃	Phosphine
SiH ₄	Silane
HCHO	Formaldehyde
C ₂ H ₄ O ₃	Peracetic Acid
DMA	Dimethylamine